

4 PIN DIP VERY HIGH ISOLATION VOLTAGE PHOTOCOUPLER

CNY64S series

Features

- High Voltage
 $BV_{CEO}=80V$ (min.)
- Operating temperature up to $+85^{\circ}C$
- High isolation voltage between input and output
 $V_{IOTM} = 8200 V$ perk for CNY64
 $V_{IOTM} = 10000 V$ perk for CNY64-V
- Rated recurring peak voltage (repetitive)
 $V_{IORM} = 2200 V$
- Creepage current resistance according to VDE 0303/IEC 60112
 comparative tracking index: $CTI \geq 200$
- Thickness through insulation $\geq 3mm$
- Pb free and RoHS compliant.
- CUL approved (No. E214129)
- VDE approved (No. 40027351)
- FIMKO approved (No. 25464)

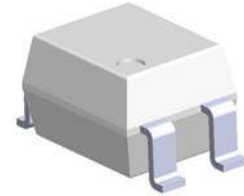

Description

The CNY64S series contains an infrared emitting diode optically coupled to a phototransistor.

These device is packaged in an 4-pin SMD package and providing a distance between input and output for highest safety requirement of $>3mm$.

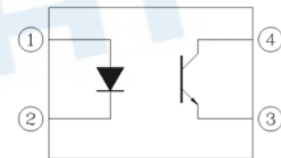

1. Anode
2. Cathode
3. Emitter
4. Collector

Applications

- Switch mode power supply
- Line receiver
- Computer peripheral interface
- Microprocessor system interface
- Circuits for safe protective separation against electrical shock according to safety class II (reinforced isolation):
 - for appl. class I - IV at mains voltage $\leq 300 V$
 - for appl. class I - IV at mains voltage $\leq 600 V$
 - for appl. class I - III at mains voltage $\leq 1000 V$
 according to DIN EN 60747-5-5

4 PIN DIP VERY HIGH ISOLATION VOLTAGE PHOTOCOUPLER

CNY64S series

Absolute Maximum Ratings ($T_a=25^\circ\text{C}$)

Parameter		Symbol	Rating	Unit
Input	Forward current	I_F	75	mA
	Peak forward current (<10 μs)	I_{FM}	1.5	A
	Reverse voltage	V_R	5	V
	Power dissipation	P_D	120	mW
Output	Collector current	I_C	50	mA
	Collector power dissipation	P_C	150	mW
	Collector-Emitter voltage	V_{CEO}	80	V
	Emitter-Collector voltage	V_{ECO}	7	V
Total power dissipation		P_{tot}	250	mW
Isolation voltage ^{*1}		V_{iso}	8200	Vrms
Operating temperature		T_{opr}	-55~+85	$^\circ\text{C}$
Storage temperature		T_{stg}	-55~+100	$^\circ\text{C}$
Soldering temperature ^{*2}		T_{sol}	260	$^\circ\text{C}$

Notes

*1 AC for 1 minute, R.H.= 40 ~ 60% R.H. In this test, pins 1 & 2 are shorted together, and pins 3 & 4 are shorted together.

*2 2mm from case, <10 seconds.

4 PIN DIP VERY HIGH ISOLATION VOLTAGE PHOTOCOUPLER

CNY64S series

Electrical Characteristics ($T_a=25^\circ\text{C}$ unless specified otherwise)

Input

Parameter	Symbol	Min.	Typ.*	Max.	Unit	Condition
Forward voltage	V_F	-	1.6	2.0	V	$I_F = 50\text{mA}$
Reverse current	I_R	-	-	10	μA	$V_R = 5\text{V}$
Input capacitance	C_{in}	-	-	100	pF	$V = 0, f = 1\text{MHz}$

Output

Parameter	Symbol	Min.	Typ.*	Max.	Unit	Condition
Collector-Emitter dark current	I_{CEO}	-	-	200	nA	$V_{CE} = 20\text{V}, I_F = 0\text{mA}$
Collector-Emitter breakdown voltage	BV_{CEO}	80	-	-	V	$I_C = 1\text{mA}$
Emitter-Collector breakdown voltage	BV_{ECO}	7	-	-	V	$I_E = 0.1\text{mA}$
Collector-Emitter capacitance	C_{CE}	-	-	50	pF	$V_{CE} = 0\text{V}, f = 1\text{MHz}$

Transfer Characteristics

Parameter	Symbol	Min.	Typ.*	Max.	Unit	Condition
Current Transfer Ratio	CNY64	50	-	300	%	$I_F = 5\text{mA}, V_{CE} = 5\text{V}$
	CNY64A	63	-	125		
	CNY64B	100	-	200		
Collector-emitter saturation voltage	$V_{CE(sat)}$	-	-	0.3	V	$I_F = 10\text{mA}, I_C = 1\text{mA}$
Coupling capacitance	C_{IO}	-	0.3	-	pF	$f=1\text{MHz}$
Isolation resistance	R_{IO}	10^{11}	-	-	Ω	$V_{IO} = 500\text{Vdc}$
Turn-on time	T_{on}	-	6	18	μs	$V_{CC} = 5\text{V}, I_C = 5\text{mA}, R_L = 100\Omega$
Turn-off time	T_{off}	-	7	18		
Rise time	t_r	-	3	18		$V_{CC} = 5\text{V}, I_C = 5\text{mA}, R_L = 100\Omega$
Fall time	t_f	-	5	18		

* Typical values at $T_a = 25^\circ\text{C}$

4 PIN DIP VERY HIGH ISOLATION VOLTAGE PHOTOCOUPLER

CNY64S series

Typical Performance Curves

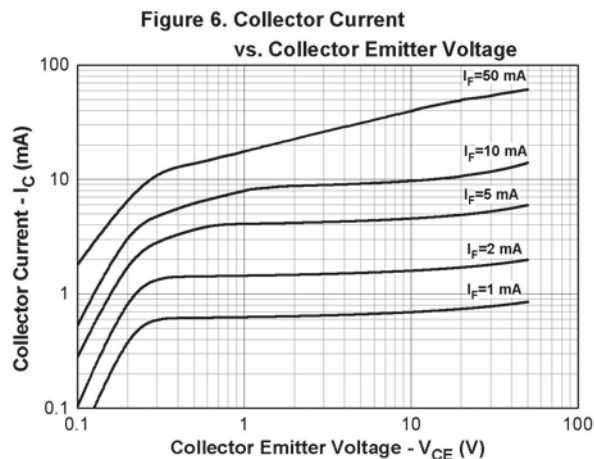
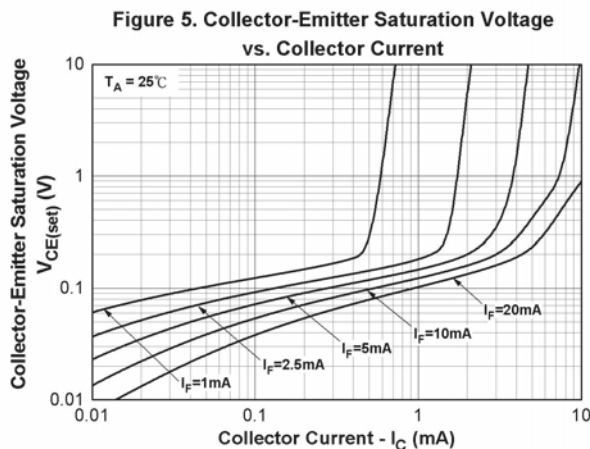
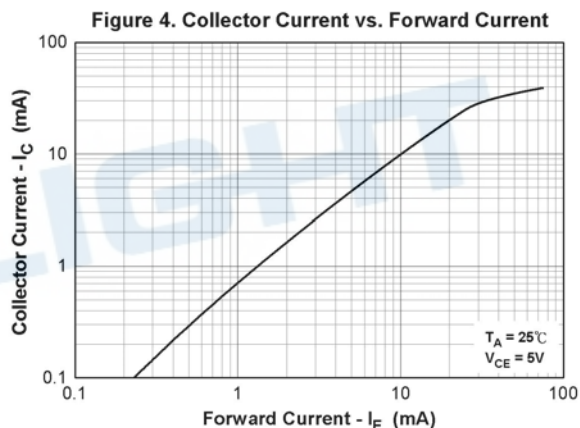
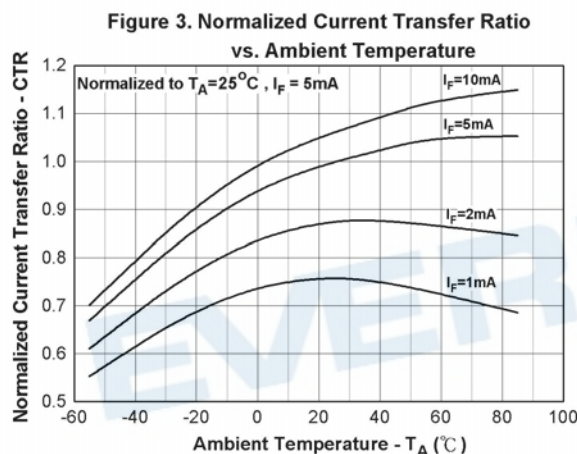
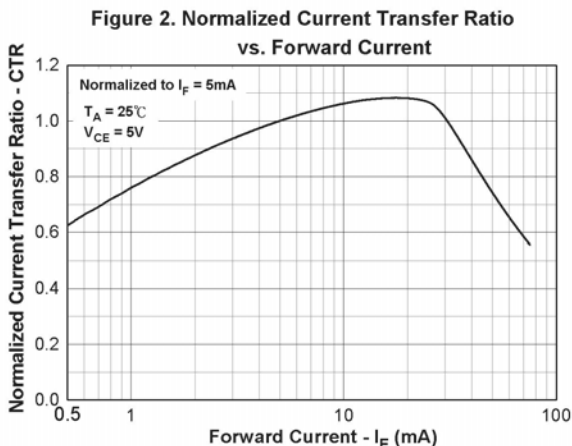
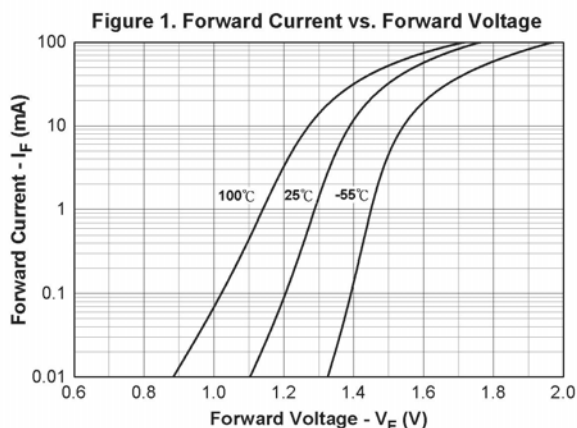

4 PIN DIP VERY HIGH ISOLATION VOLTAGE PHOTOCOUPLER

CNY64S series

Figure.7 Collector Dark Current vs. Ambient Temperature

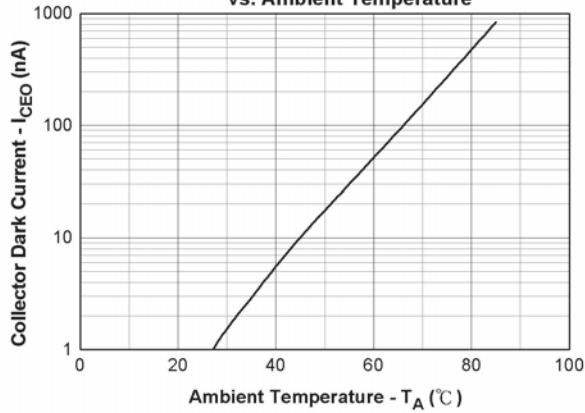

Figure 8. Turn on/off Time vs. Forward Current

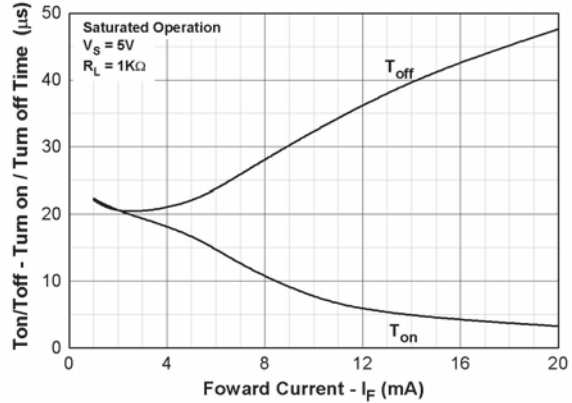

Figure 9. Turn on/off Time vs. Collector Current

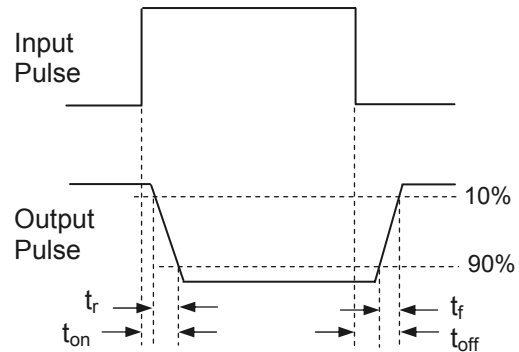
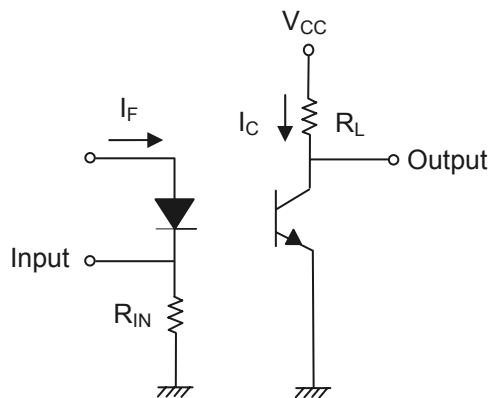
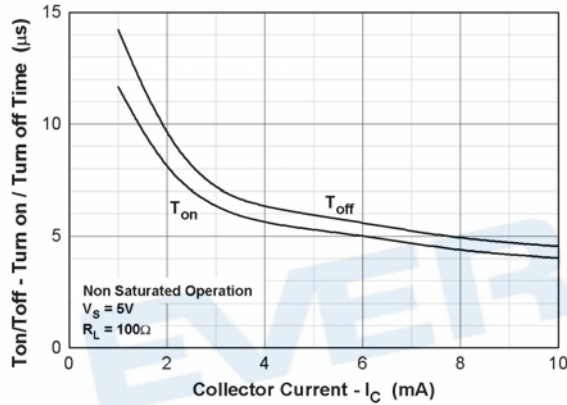

Figure 10. Switching Time Test Circuit & Waveforms

4 PIN DIP VERY HIGH ISOLATION VOLTAGE PHOTOCOUPLER

CNY64S series

Order Information

Part Number

CNY64SX-V

Note

X = CTR rank option (A, B or none)

V = VDE safety (optional)

Option	Description	Packing quantity
CNY64S	Standard	60 units per tube
CNY64S-V	Standard + VDE	60 units per tube
CNY64S(TA)	Standard	500 units per tube

EVERLIGHT

4 PIN DIP VERY HIGH ISOLATION VOLTAGE PHOTOCOUPLER

CNY64S series

Package Drawings

(Dimensions in mm)

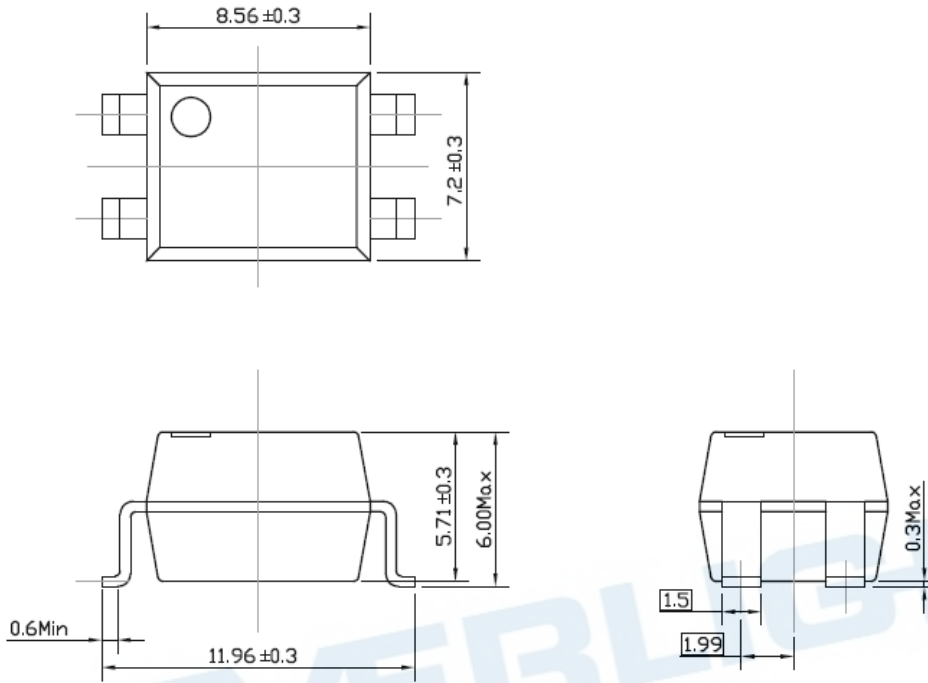

Recommended pad layout for surface mount leadform

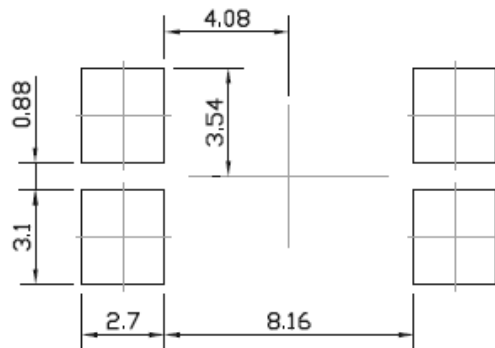

4 PIN DIP VERY HIGH ISOLATION VOLTAGE PHOTOCOUPLER

CNY64S series

Device Marking

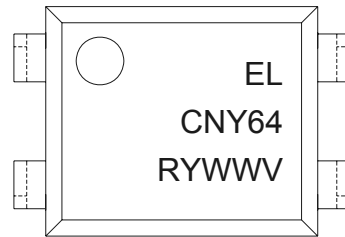

Notes

EL	denotes Everlight
CNY64	denotes Part no.
R	denotes CTR rank (A or B)
Y	denotes 1 digit Year code
WW	denotes 2 digit Week code
V	denotes VDE safety (optional)

EVERLIGHT

4 PIN DIP VERY HIGH ISOLATION VOLTAGE PHOTOCOUPLER

CNY64S series

Tape & Reel Packing Specifications

Option TA

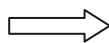
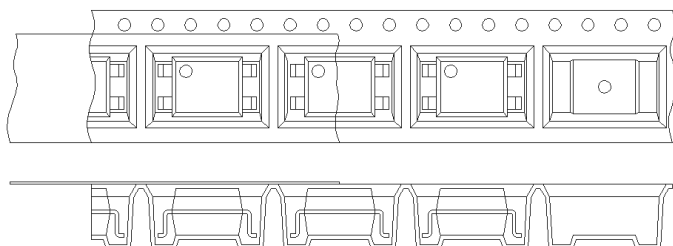

Direction of feed from reel

Tape dimensions

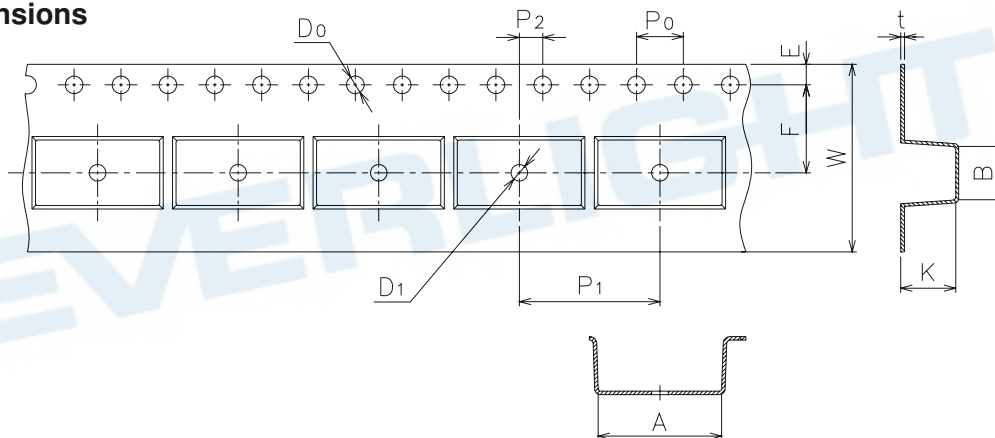

Dimension No.	A	B	Do	D1	E	F
Dimension(mm)	12.6±0.1	6.6±0.1	1.5+0.1/-0	1.5±0.1	1.75±0.1	7.5±0.1
Dimension No.	Po	P1	P2	t	W	K
Dimension(mm)	4.0±0.1	16.0±0.1	2.0±0.1	0.5±0.05	16.0±0.3	7.31±0.1

4 PIN DIP VERY HIGH ISOLATION VOLTAGE PHOTOCOUPLER

CNY64S series

Solder Reflow Temperature Profile

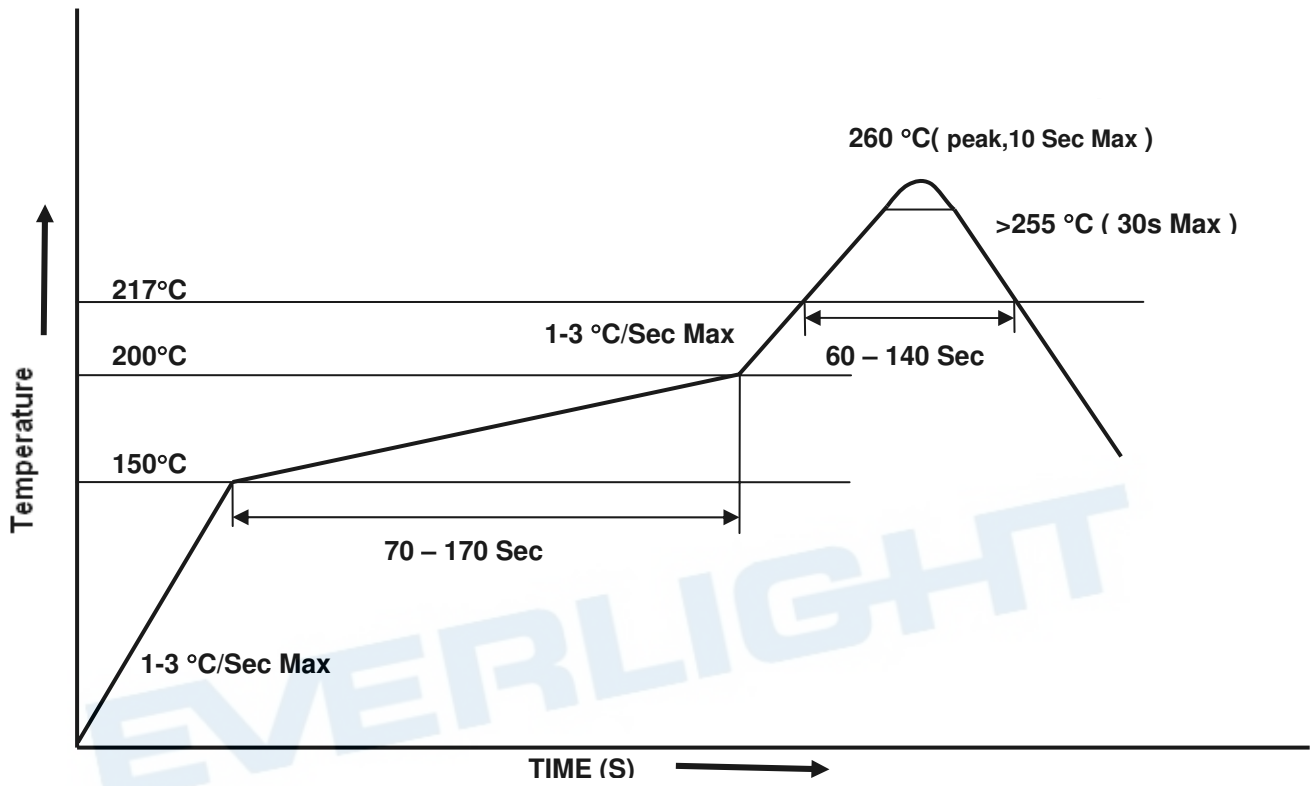

4 PIN DIP VERY HIGH ISOLATION VOLTAGE PHOTOCOUPLER

CNY64S series

DISCLAIMER

1. The specifications in this datasheet may be changed without notice. EVERLIGHT reserves the authority on material change for above specification.
2. When using this product, please observe the absolute maximum ratings and the instructions for use as outlined in this datasheet. EVERLIGHT assumes no responsibility for any damage resulting from use of the product which does not comply with the absolute maximum ratings and the instructions included in this datasheet.
3. These specification sheets include materials protected under copyright of EVERLIGHT. Reproduction in any form is prohibited without the specific consent of EVERLIGHT.

EVERLIGHT