

4 PIN DIP PHOTOTRANSISTOR PHOTOCOUPLER EL817H-G Series

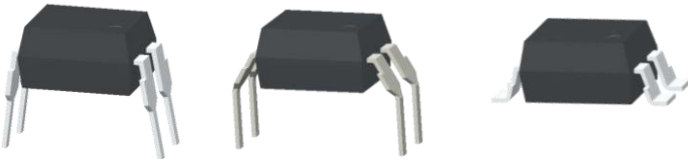

Schematic

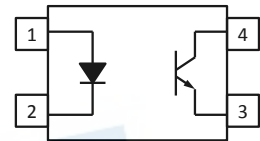

Features:

- Halogens free.
(Br < 900ppm, Cl < 900ppm, Br+Cl < 1500ppm)
- Current transfer ratio
(CTR: 50~400% at $I_F = 5\text{mA}$, $V_{CE} = 5\text{V}$)
- Operating temperature $-55^{\circ}\text{C} \sim 125^{\circ}\text{C}$
- High isolation voltage between input and output (Viso = 5000Vrms)
- Creepage distance > 7.62mm
- Compact small outline package
- Compliance with EU REACH.
- The product itself will remain within RoHS compliant version
- UL and cUL approved(No.E214129)
- VDE approved (No.132249)
- SEMKO approved
- NEMKO approved
- DEMKO approved
- FIMKO approved
- CQC approved

Pin Configuration

1. Anode
2. Cathode
3. Emitter
4. Collector

Description

The EL817H-G series of devices each consist of an infrared emitting diodes, optically coupled to a phototransistor detector. They are packaged in a 4-pin DIP package and available in wide-lead spacing and SMD option.

Applications

- Programmable controllers
- System appliances, measuring instruments
- Telecommunication equipments
- Home appliances, such as fan heaters, etc.
- Signal transmission between circuits of different potentials and impedances

Absolute Maximum Ratings (Ta=25°C)*1

	Parameter	Symbol	Rating	Unit
Input	Forward current	I_F	50	mA
	Peak forward current (1us, pulse)	I_{FP}	1	A
	Reverse voltage	V_R	6	V
	Power dissipation	P_D	100	mW
Output	Power dissipation	P_C	150	mW
	Collector current	I_C	50	mA
	Collector-Emitter voltage	V_{CEO}	80	V
	Emitter-Collector voltage	V_{ECO}	7	V
	Total Power Dissipation	P_{TOT}	200	mW
	Isolation Voltage*2	V_{ISO}	5000	V rms
	Operating Temperature	T_{OPR}	-55 to 125	°C
	Storage Temperature	T_{STG}	-55 to 150	°C
	Soldering Temperature*3	T_{SOL}	260	°C

Notes:

*1 Stresses in excess of the absolute maximum ratings can cause permanent damage to the device. Functional operation of the device is not implied at these or any other conditions in excess of those given in the operational sections of this document.

Exposure to absolute maximum ratings for extended periods of the time can adversely affect reliability.

*2 AC for 1 minute, R.H.= 40 ~ 60% R.H. In this test, pins 1, 2 are shorted together, and pins 3, 4 are shorted together.

*3 For 10 seconds

Electro-Optical Characteristics (Ta=25°C unless specified otherwise)

Input

Parameter	Symbol	Min.	Typ.	Max.	Unit	Condition
Forward Voltage	V_F	-	1.2	1.4	V	$I_F = 10\text{mA}$
Reverse Current	I_R	-	-	10	μA	$V_R = 5\text{V}$
Input capacitance	C_{in}	-	30	250	pF	$V = 0, f = 1\text{kHz}$

Output

Parameter	Symbol	Min	Typ.	Max.	Unit	Condition
Collector-Emitter dark current	I_{CEO}	-	-	200	nA	$V_{CE} = 48\text{V}, I_F = 0\text{mA}$
Collector-Emitter breakdown voltage	BV_{CEO}	80	-	-	V	$I_C = 0.1\text{mA}$
Emitter-Collector breakdown voltage	BV_{ECO}	7	-	-	V	$I_E = 0.1\text{mA}$

Transfer Characteristics

Parameter	Symbol	Min	Typ.	Max.	Unit	Condition
Current Transfer ratio	EL817H	50	-	400	%	$I_F = 5\text{mA}, V_{CE} = 5\text{V}$
	EL817HA	80	-	160		
	EL817HB	130	-	260		
	EL817HC	200	-	400		
Collector-Emitter saturation voltage	$V_{CE(sat)}$	-	-	0.35	V	$I_F = 20\text{mA}, I_C = 1\text{mA}$
Isolation resistance	R_{IO}	5×10^{10}	-	-	Ω	$V_{IO} = 500\text{Vdc}, 40 \sim 60\% \text{ R.H.}$
Floating capacitance	C_{IO}	-	0.6	1.0	pF	$V_{IO} = 0, f = 1\text{MHz}$
Cut-off frequency	f_c	-	80	-	kHz	$V_{CE} = 5\text{V}, I_C = 2\text{mA}, R_L = 100\Omega, -3\text{dB}$
Rise time	t_r	-	6	18	μs	$V_{CE} = 2\text{V}, I_C = 2\text{mA}, R_L = 100\Omega$
Fall time	t_f	-	8	18	μs	

* Typical values at $T_a = 25^\circ\text{C}$

Typical Electro-Optical Characteristics Curves*

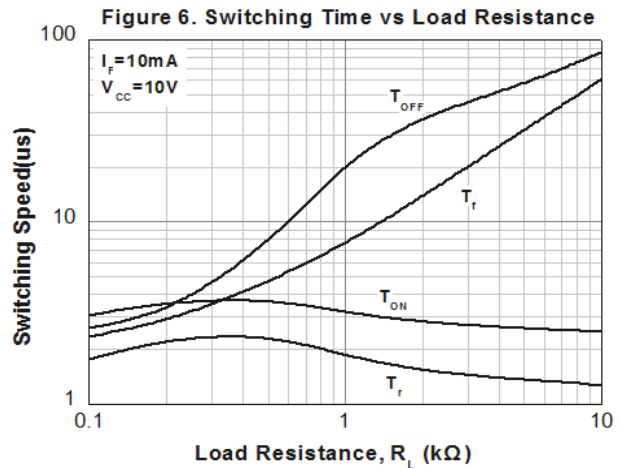
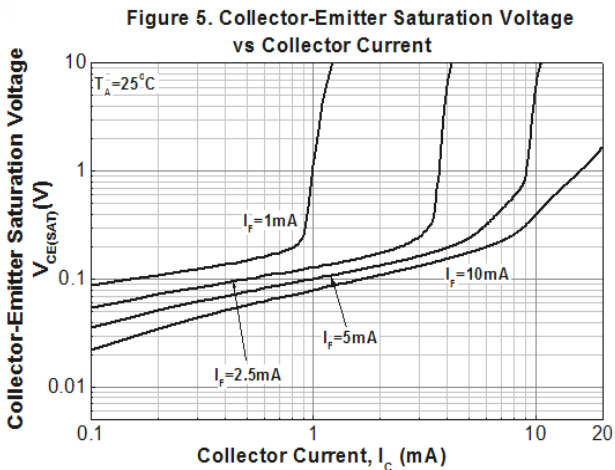
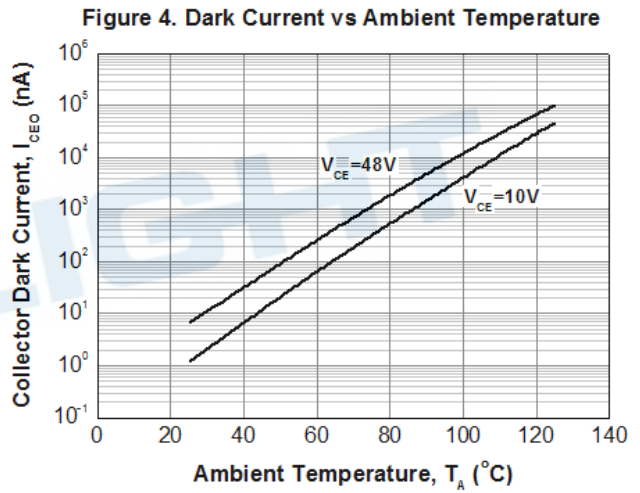
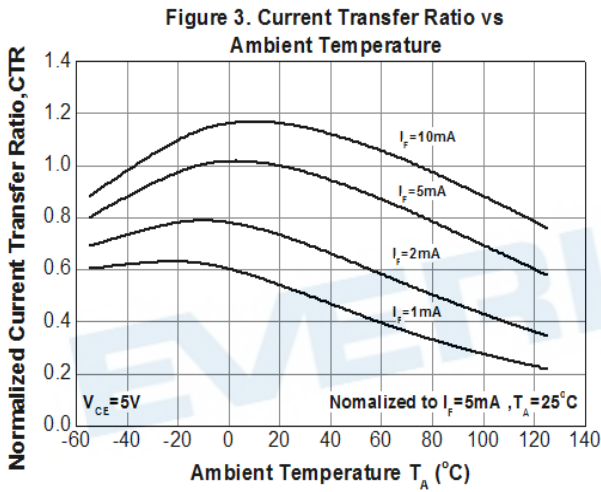
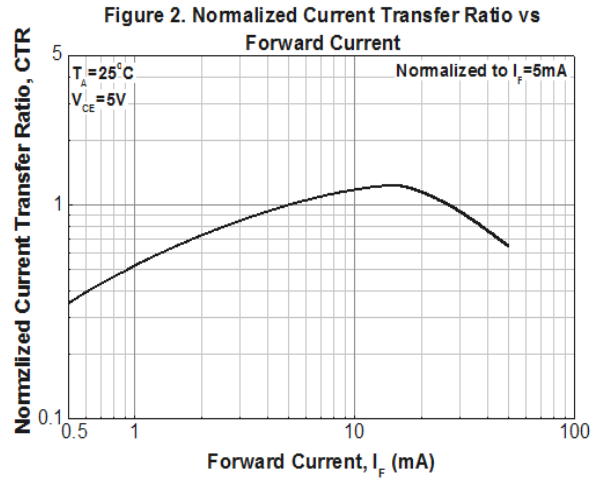
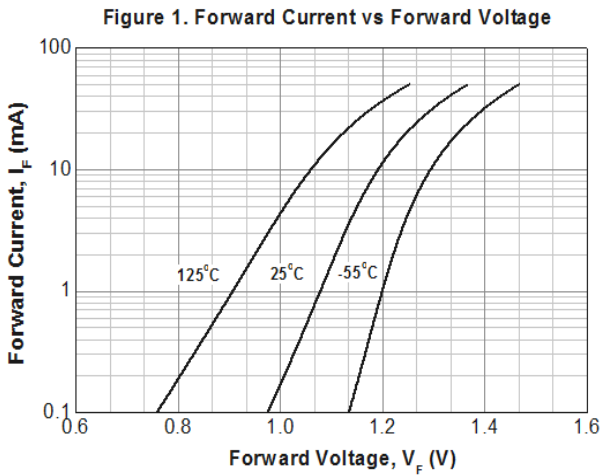

*Please be aware that all data in the graph are just for reference and not for guarantee.

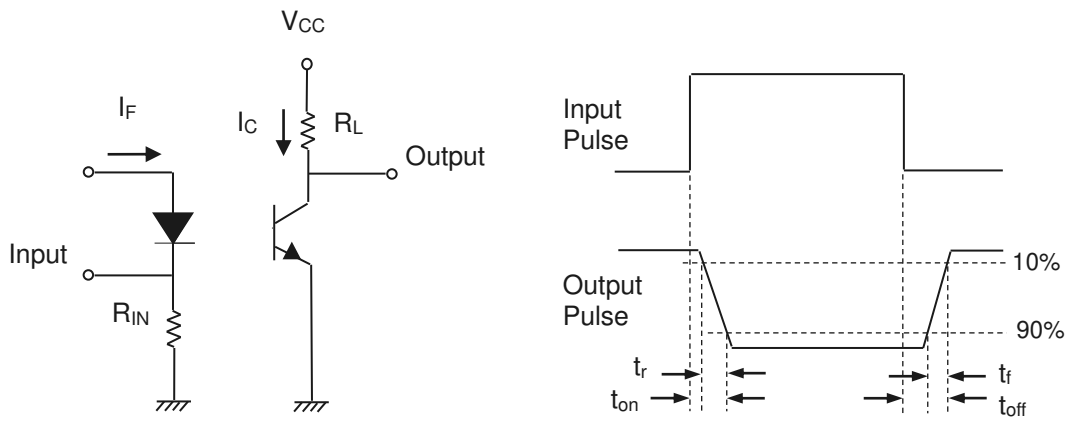

Figure 7. Switching Time Test Circuit & Waveforms

EVERLIGHT

Order Information

Part Number

EL817HX(Y)(Z)-VG

Note

- H = Operating high temperature
- X = Lead form option (S1, S2, M or none)
- Y = CTR Rank (A, B, C or none)
- Z = Tape and reel option (TU, TD or none)
- V = VDE safety (optional)
- G = Halogens free

Option	Description	Packing quantity
None	Standard DIP-4	100 units per tube
M	Wide lead bend (0.4 inch spacing)	100 units per tube
S1 (TU)	Surface mount lead form (low profile) + TU tape & reel option	1500 units per reel
S1 (TD)	Surface mount lead form (low profile) + TD tape & reel option	1500 units per reel
S2 (TU)	Surface mount lead form (low profile) + TU tape & reel option	2000 units per reel
S2 (TD)	Surface mount lead form (low profile) + TD tape & reel option	2000 units per reel

Package Dimension (Dimensions in mm)

Standard DIP Type

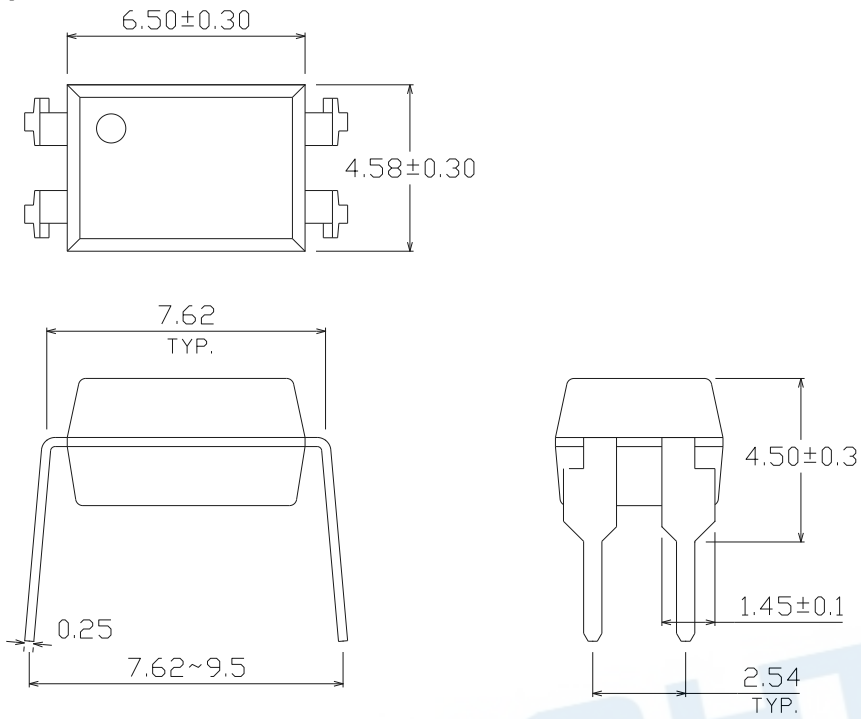

Option M Type

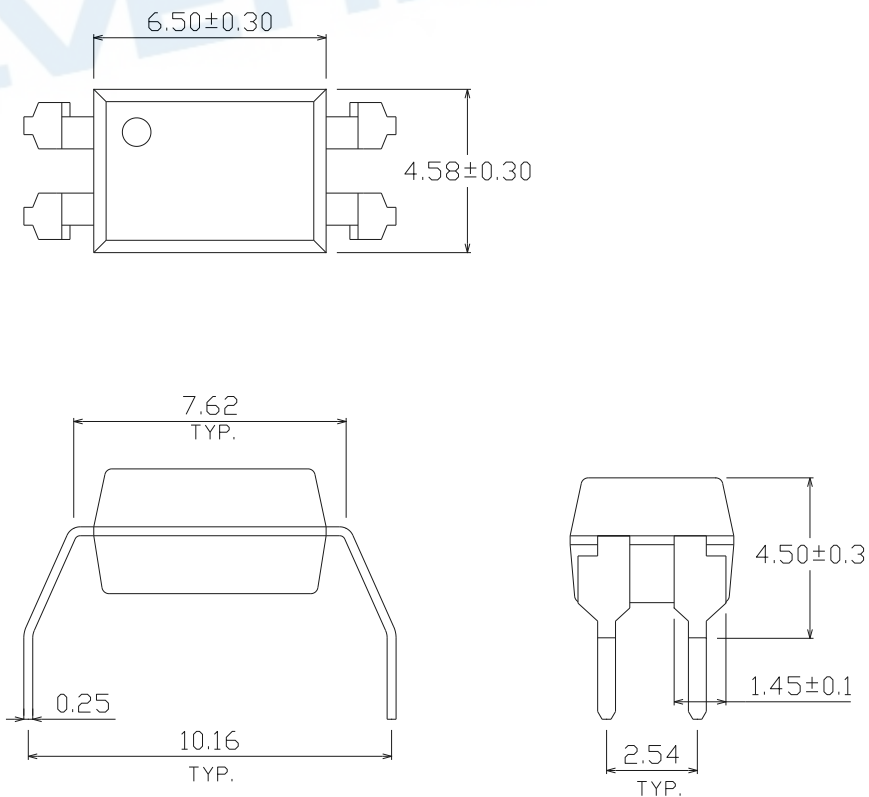

Option S1 Type

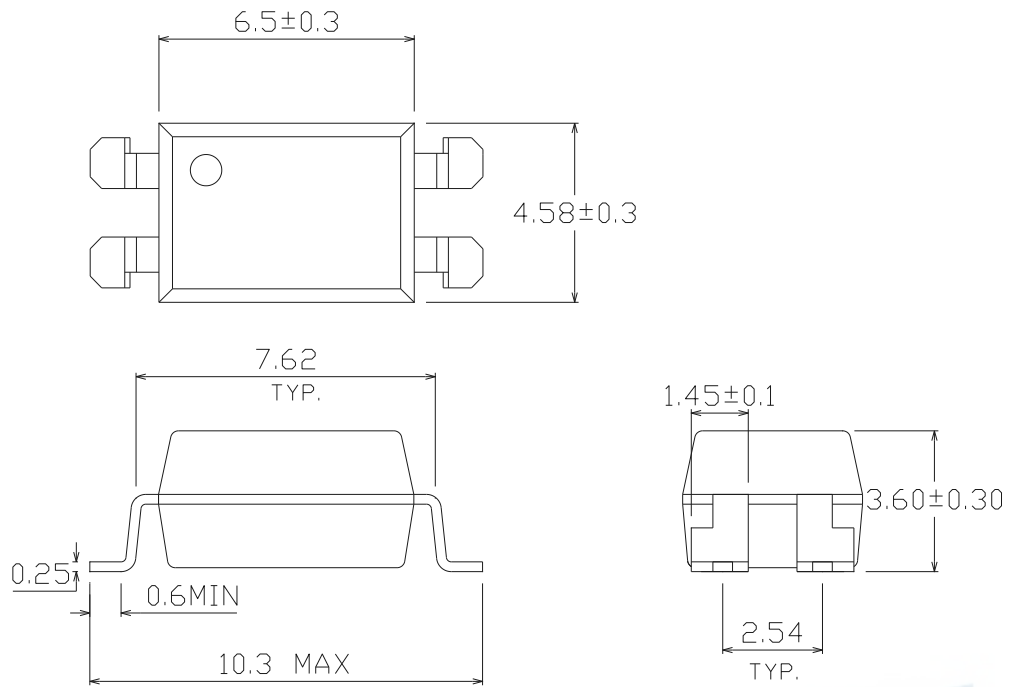

Option S2 Type

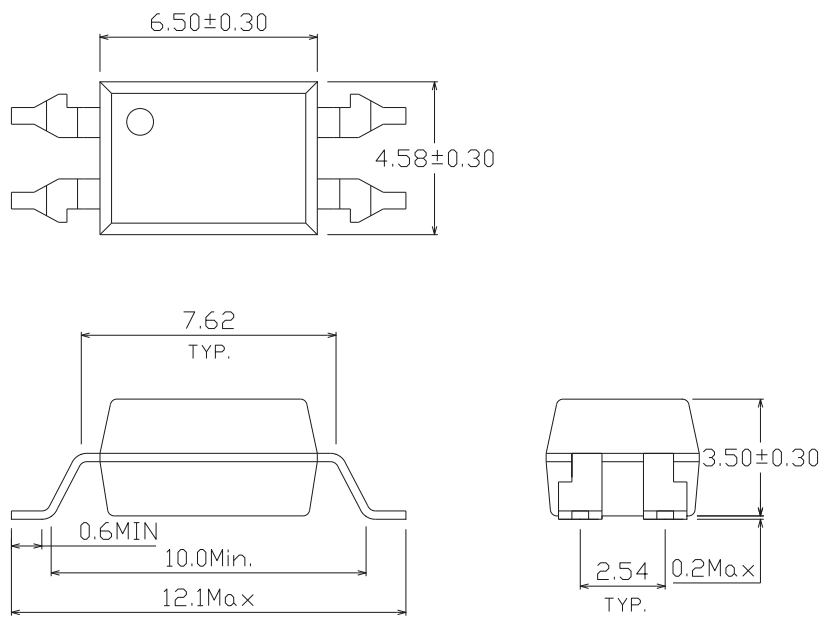

Recommended pad layout for surface mount leadform

For S1 option

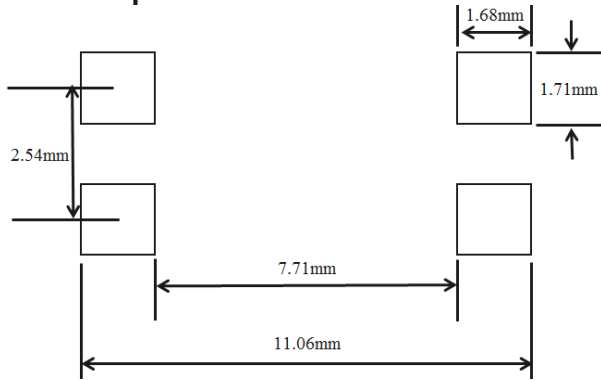

For S2 option

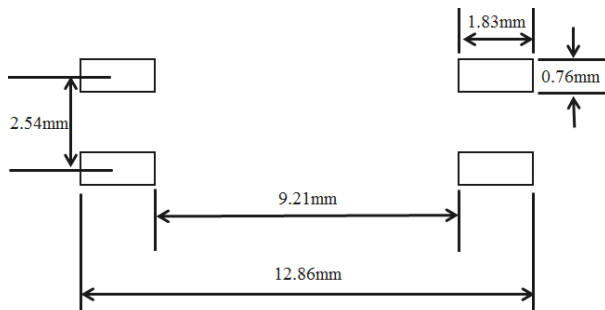

Notes

Suggested pad dimension is just for reference only.
Please modify the pad dimension based on individual need.

Device Marking



Notes

EL denotes EVERLIGHT
817 denotes Device Number
H denotes Operating High Temperature
F denotes Factory Code (G: China and Green part)
R denotes CTR Rank (A, B, C or none)
Y denotes 1 digit Year code
WW denotes 2 digit Week code
V denotes VDE (optional)

Tape & Reel Packing Specifications

Option TD

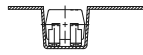
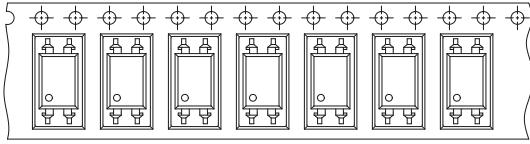

Direction of feed from reel

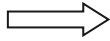

Option TU

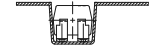
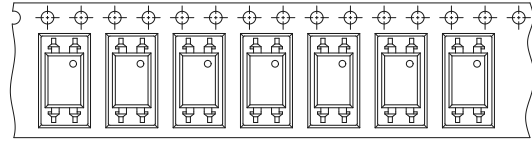

Direction of feed from reel

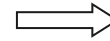

Tape dimensions

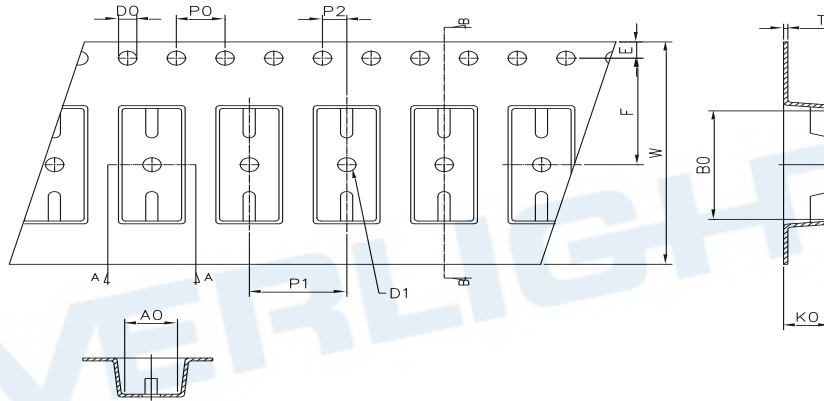

Dimension No.	Ao	Bo	Do	D1	E	F
Dimension (mm) S1	4.90±0.1	10.40±0.1	1.5±0.1	1.50±0.1	1.75±0.1	7.50±0.1
Dimension (mm) S2	4.88±0.1	12.55±0.1	1.5±0.1	1.50±0.1	1.75±0.1	11.5±0.1
Dimension No.	Po	P1	P2	t	W	Ko
Dimension (mm) S1	4.00±0.1	8.00±0.1	2.00±0.1	0.40±0.1	16.00±0.3	4.60±0.1
Dimension (mm) S2	4.00±0.1	8.00±0.1	2.00±0.1	0.40±0.1	24.00±0.3	4.00±0.1

Precautions for Use

1. Soldering Condition

1.1 (A) Maximum Body Case Temperature Profile for evaluation of Reflow Profile

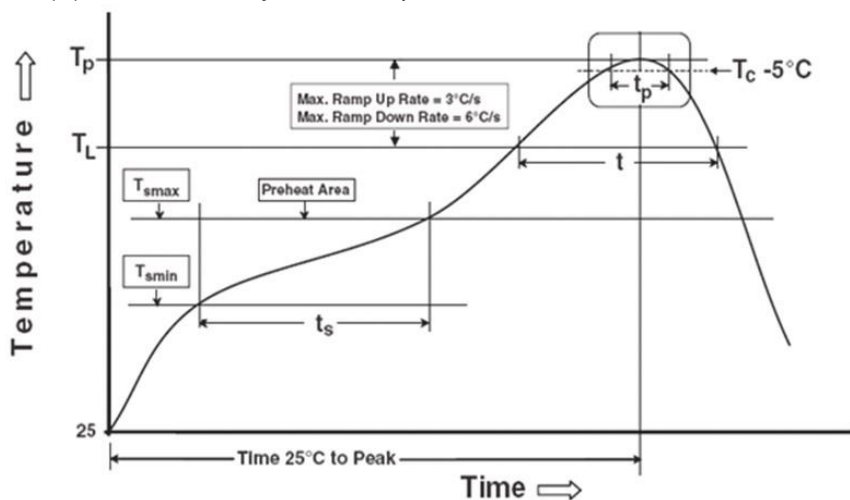

Note:

Reference: IPC/JEDEC J-STD-020D

Preheat

Temperature min (T_{smin})	150 °C
Temperature max (T_{smax})	200°C
Time (T_{smin} to T_{smax}) (t_s)	60-120 seconds
Average ramp-up rate (T_{smax} to T_p)	3 °C/second max

Other

Liquidus Temperature (T_L)	217 °C
Time above Liquidus Temperature (t_L)	60-100 sec
Peak Temperature (T_p)	260°C
Time within 5 °C of Actual Peak Temperature: $T_p - 5^\circ C$	30 s
Ramp- Down Rate from Peak Temperature	6°C /second max.
Time 25°C to peak temperature	8 minutes max.
Reflow times	3 times

DISCLAIMER

1. Above specification may be changed without notice. EVERLIGHT will reserve authority on material change for above specification.
2. The graphs shown in this datasheet are representing typical data only and do not show guaranteed values.
3. When using this product, please observe the absolute maximum ratings and the instructions for use outlined in these specification sheets. EVERLIGHT assumes no responsibility for any damage resulting from use of the product which does not comply with the absolute maximum ratings and the instructions included in these specification sheets.
4. These specification sheets include materials protected under copyright of EVERLIGHT. Reproduction in any form is prohibited without the specific consent of EVERLIGHT.
5. This product is not intended to be used for military, aircraft, automotive, medical, life sustaining or life saving applications or any other application which can result in human injury or death. Please contact authorized Everlight sales agent for special application request.
6. Statements regarding the suitability of products for certain types of applications are based on Everlight's knowledge of typical requirements that are often placed on Everlight products in generic applications. Such statements are not binding statements about the suitability of products for a particular application. It is the customer's responsibility to validate that a particular product with the properties described in the product specification is suitable for use in a particular application. Parameters provided in datasheets and/or specifications may vary in different applications and performance may vary over time. All operating parameters, including typical parameters, must be validated for each customer application by the customer's technical experts. Product specifications do not expand or otherwise modify Everlight's terms and conditions of purchase, including but not limited to the warranty expressed therein.