



Through Hole Lamp Product Data Sheet LTLR1DEKVJNNH155T

Spec No. :DS20-2023-0098
Effective Date: 08/12/2023
Revision: -

LITE-ON DCC

RELEASE

Through Hole Lamp
LTLR1DEKVJNNH155T

Through Hole Lamp

LTLR1DEKVJNNH155T

Rev	Description	By	Date
P01	Preliminary New Specification (RDR-20221105)	Perry Wang	10/21/2022
P02	Outline Dimensions notes revise.	Perry Wang	03/08/2023
Above data for PD and Customer tracking only			
-	New Specification, Upload in OPB2 system	Chalerm Ya.	08/02/2023

Through Hole Lamp LTLR1DEKVJNNH155T

1. Description

CBI (Circuit Board Indicator) is a black plastic right angle Holder (Housing) which mates with Lite-On LED lamps. Lite-On CBI is available in a wide variety of packages, including top-view (Spacer) or right angle and horizontal or vertical arrays which is stackable and easy to assembly.

1.1. Features

- Designed for ease in circuit board assembly.
- Black case enhance contrast ratio.
- Low power consumption.
- Lead free product & RoHS Compliant.
- T-1 lamp: Source bi-colors are AllInGaP green 569nm and AllInGaP red 631nm with white diffused lens.
- It is in tape and reel packing.

1.2. Applications

- Communication.
- Computer.
- Consumer.
- Industrial.

2. Outline Dimensions

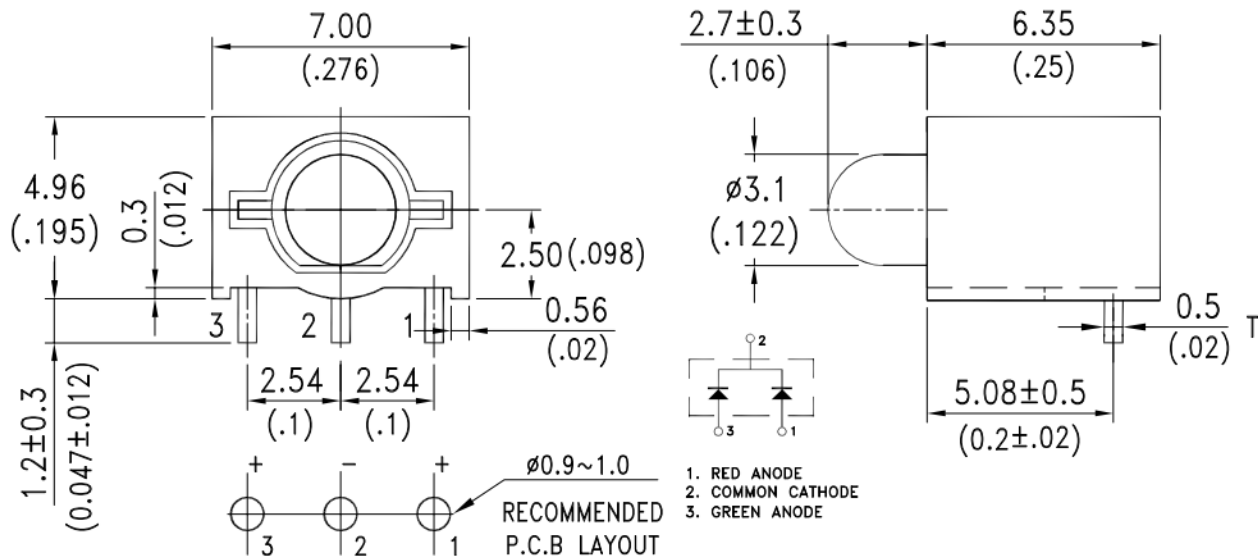

Notes :

1. All dimensions are in millimeters (inches).
2. Tolerance is ± 0.25 mm (.010") unless otherwise noted.
3. The Holder (Housing) material is plastic black.
4. LED lamp is yellow green/red with white diffused lens.
5. Specifications are subject to change without notice.

Through Hole Lamp LTLR1DEKVJNNH155T

3. Absolute Maximum Ratings at TA=25°C

Parameter	Green	Red	Unit
Power Dissipation	75	75	mW
Peak Forward Current (Duty Cycle $\leq 1/10$, Pulse Width ≤ 10 ms)	60	90	mA
DC Forward Current	30	30	mA
Derating Linear From 50°C	0.4	0.4	mA/°C
Operating Temperature Range	-40°C to + 100°C		
Storage Temperature Range	-55°C to + 100°C		
Lead Soldering Temperature [1.6mm (.062") From Body]	260°C for 5 Seconds Max.		

4. Electrical / Optical Characteristics at TA=25°C

Parameter	Symbol	Color	Min.	Typ.	Max.	Unit	Test Condition
Radiant Intensity	Iv	Red	65	110	250	mcd	IF = 20mA Note 1,4
		Green	65	110	450		
Viewing Angle	$\theta_{1/2}$	Red		45		deg	Note 2 (Fig.6)
		Green		45			
Peak Emission Wavelength	λ_P	Red		639		nm	Measurement @Peak (Fig.1)
		Green		575			
Dominant Wavelength	λ_d	Red		631		nm	Note 3
		Green		569			
Spectral Line Half-Width	$\Delta\lambda$	Red		20		nm	
		Green		11			
Forward Voltage	VF	Red		2.0	2.4	V	IF = 20mA
		Green		2.1	2.4		
Reverse Current	IR	Red Green			10	μ A	VR = 5V

NOTE:

- Luminous intensity is measured with a light sensor and filter combination that approximates the CIE eye-response curve.
- $\theta_{1/2}$ is the off-axis angle at which the luminous intensity is half the axial luminous intensity.
- The dominant wavelength, λ_d is derived from the CIE chromaticity diagram and represents the single wavelength which defines the color of the device.
- Iv guarantee must be included with $\pm 30\%$ testing tolerance.
- Reverse current is controlled by dice source.
- Reverse voltage (VR) condition is applied for IR test only. The device is not designed for reverse operation.

Through Hole Lamp LTLR1DEKVJNNH155T

5. Typical Electrical / Optical Characteristics Curves

(25°C Ambient Temperature Unless Otherwise Noted)

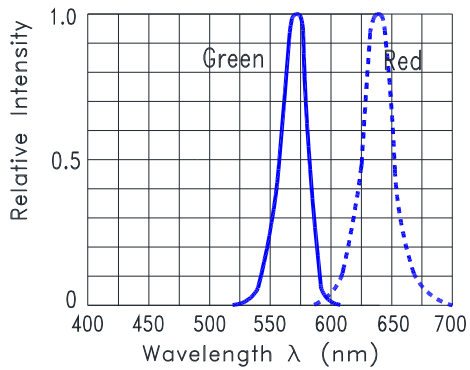

Fig.1 Relative Intensity VS. Wavelength

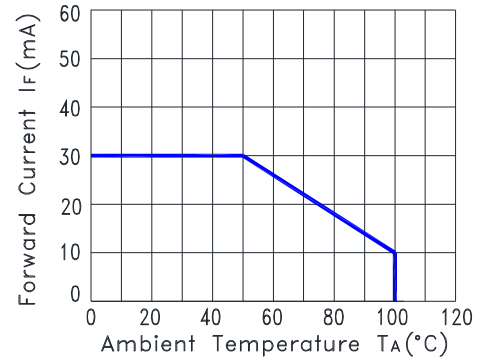

Fig.2 Forward Current Derating Curve

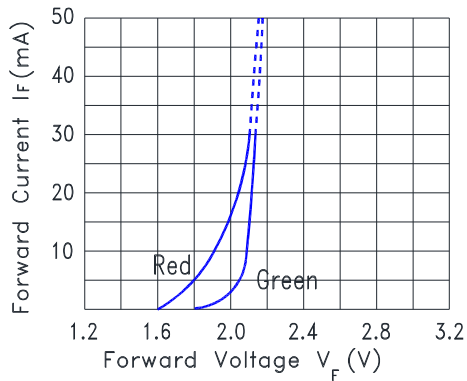

Fig.3 Forward Current vs. Forward Voltage

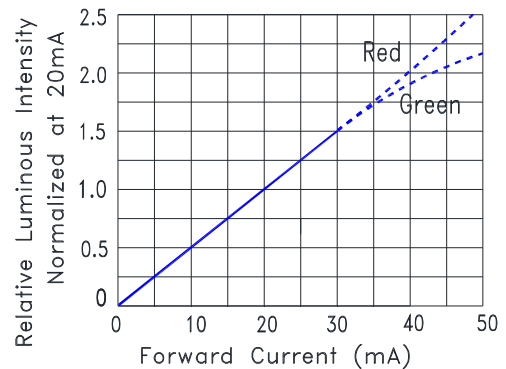

Fig.4 Relative Luminous Intensity vs. Forward Current

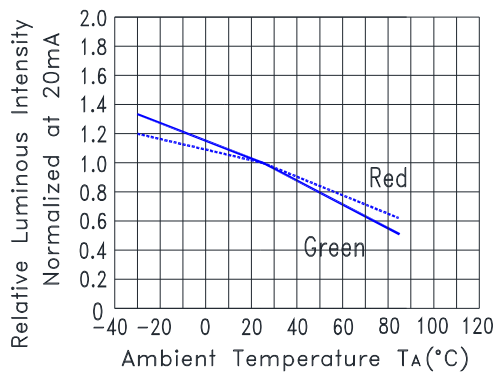

Fig.5 Relative Luminous Intensity VS. Ambient Temperature

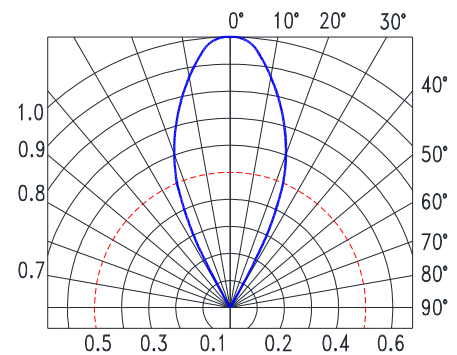
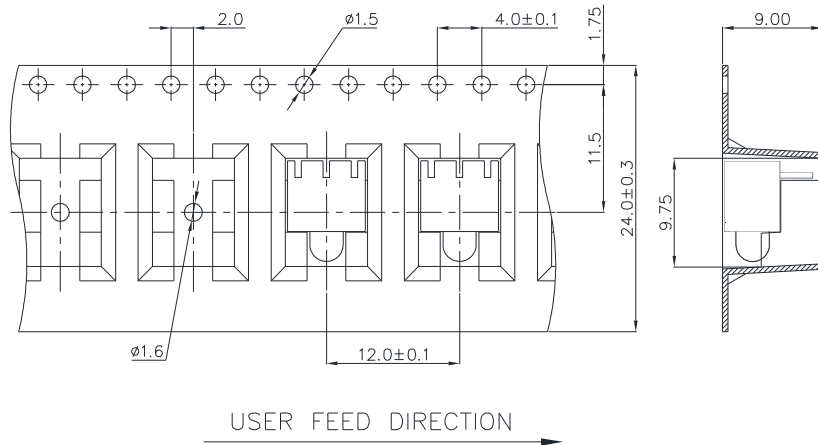

Fig.6 Spatial Distribution

Through Hole Lamp LTLR1DEKVJNNH155T

6. Packing Specification

Packing Carrier Dimensions



1. 10 sprocket hole pitch cumulative tolerance ± 0.20
2. Material : Black Conductive Polystyrene Alloy
3. Thickness : 0.50 ± 0.06 mm
4. Component load per 13" reel : 450pcs

Packing Reel Dimensions

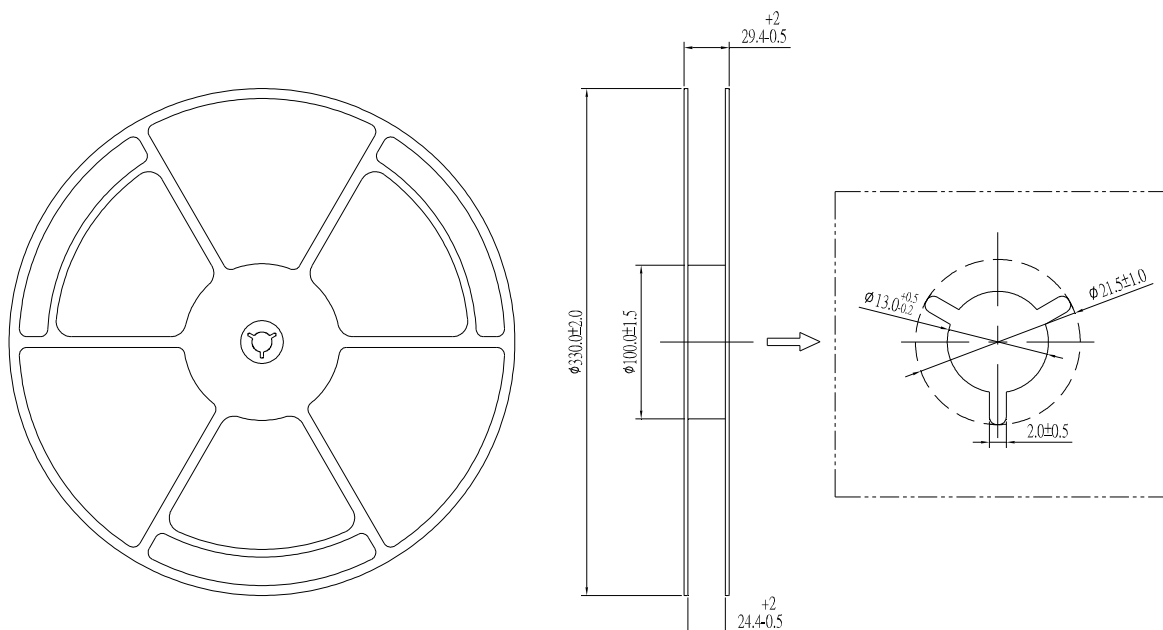

Through Hole Lamp LTLR1DEKVJNNH155T

Carton Specification

1 Reel with 1 Humidity indicator card and 1 Desiccant are packed in 1 Moisture Barrier Bag (MBB)

2 Moisture Barrier Bags packed in 1 Inner Carton

Total 900pcs (450pcs*2) per Inner Carton

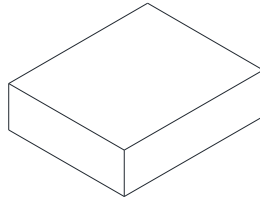

INNER CARTON
361 x 358 x 75 mm

10 Inner Cartons per Outer Carton

Total 9,000pcs (900pcs*10) per Outer Carton

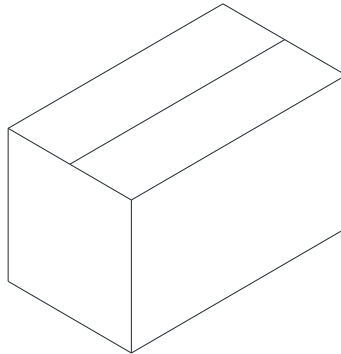

OUTER CARTON
740 x 390 x 395 mm

Through Hole Lamp LTLR1DEKVJNNH155T

7. Bin Table Specification

Luminous Intensity Unit : mcd @20mA					
Red			Green		
Bin Code	Min.	Max.	Bin Code	Min.	Max.
DE	65	140	DE	65	140
FG	140	250	FG	140	250
			HJ	250	450

Note: Tolerance of each bin limit is $\pm 15\%$

Dominant Wavelength (Green), Unit: nm, IF=20mA		
Hue Bin Code	Min.	Max.
H06	564.0	568.0
H07	568.0	571.0

Note: Tolerance of each bin limit is $\pm 1\text{nm}$

Through Hole Lamp LTLR1DEKVJNNH155T

8. CAUTIONS

8.1. Application

This LED lamp is good for application of indoor and outdoor sign, also ordinary electronic equipment.

8.2. Storage

The package is sealed:

The LEDs should be stored at 30°C or less and 70%RH or less. And the LEDs are limited to use within one year, while the LEDs is packed in moisture-proof package with the desiccants inside.

The package is opened:

The storage ambient for the LEDs should not exceed 30°C temperature and 60% relative humidity.

It is recommended that LEDs out of their original packaging are IR-reflowed within 168hrs.

For extended storage out of their original packaging, it is recommended that the LEDs be stored in a sealed container with appropriate desiccant, or in a desiccator with nitrogen ambient.

LEDs stored out of their original packaging for more than 168hrs should be baked at about 60 deg C for at least 48 hours before solder assembly.

For unused component, we strongly suggest doing baking following above condition before go SMT assembly process (IR reflow) if the MBB had been opened over 168 hours to prevent MBB from not repacking well or environment moisture over standard required condition which might cause the LEDs function fail.

8.3. Cleaning

Use alcohol-based cleaning solvents such as isopropyl alcohol to clean the LEDs if necessary.

8.4. Lead Forming & Assembly

During lead forming, the leads should be bent at a point at least 2mm from the base of LED lens. Do not use the base of the lead frame as a fulcrum during forming. Lead forming must be done before soldering, at normal temperature. During assembly on PCB, use minimum clinch force possible to avoid excessive mechanical stress.

8.5. Soldering

When soldering, leave a minimum of 2mm clearance from the base of the lens/Holder to the soldering point. Dipping the lens/Holder into the solder must be avoided. Do not apply any external stress to the lead frame during soldering while the LED is at high temperature.

Recommended soldering conditions:

Soldering iron		Wave soldering	
Temperature	350°C Max.	Pre-heat	120°C Max.
Soldering time	3 seconds Max. (one time only)	Pre-heat time	100 seconds Max.
Position	No closer than 2mm from the base of the epoxy bulb	Solder wave	260°C Max.
		Soldering time	5 seconds Max.
		Dipping Position	No lower than 2mm from the base of the epoxy bulb

Through Hole Lamp LTLR1DEKVJNNH155T

Reflow	
Profile Feature	Conditions
Preheat/Soak	
Temperature Min. (T_{smin})	150°C
Temperature Max. (T_{smax})	200°C
Time (t_s) from (T_{smin} to T_{smax})	100 seconds Max.
Liquidous temperature (T_L)	217°C
Time (t_L) maintained above T_L	60~150 seconds
Peak temperature (T_P)*	250°C
Specified classification temperature (T_C)	245°C
Time (t_p) within 5°C of the temperature T_C	30 seconds Max.
Time 25°C to peak temperature	5 minutes Max.

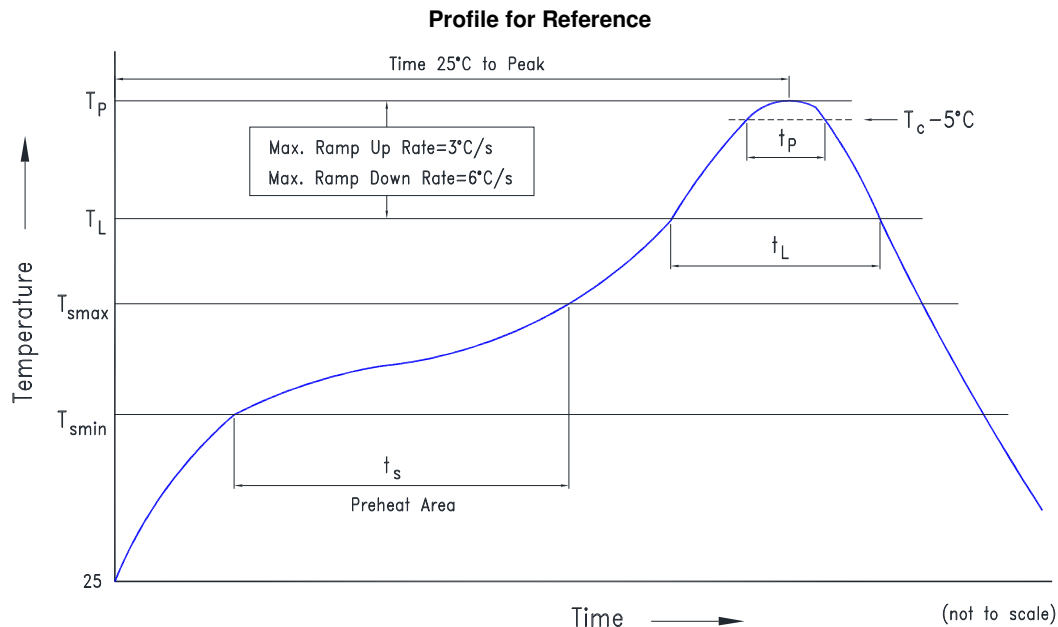

Note:

1. Excessive soldering temperature and/or time might result in deformation of the LED lens or catastrophic failure of the LED.
2. Max temperature of wave soldering or IR-Reflow is not means that Holder's HDT/Melting temperature.
3. Clinch lead frame would cause stress and might catastrophic failure of the LED when stress at high temperature.

Through Hole Lamp LTLR1DEKVJNNH155T

8.6. Drive Method

An LED is a current-operated device. In order to ensure intensity uniformity on multiple LEDs connected in parallel in an application, it is recommended that a current limiting resistor be incorporated in the drive circuit, in series with each LED as shown in Circuit A below.

Circuit model (A)

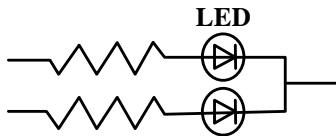

Circuit model (B)

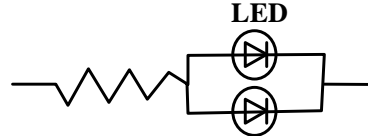

(A) Recommended circuit

(B) The brightness of each LED might appear different due to the differences in the I-V characteristics of those LEDs.

8.7. ESD (Electrostatic Discharge)

Static Electricity or power surge will damage the LED.

Suggestions to prevent ESD damage:

- Use a conductive wrist band or anti- electrostatic glove when handling these LEDs
- All devices, equipment, and machinery must be properly grounded
- Work tables, storage racks, etc. should be properly grounded
- Use ion blower to neutralize the static charge which might have built up on surface of the LEDs plastic lens as a result of friction between LEDs during storage and handing

Suggested checking list:

Training and Certification

- 8.7.1.1. Everyone working in a static-safe area is ESD-certified?
- 8.7.1.2. Training records kept and re-certification dates monitored?

Static-Safe Workstation & Work Areas

- 8.7.2.1. Static-safe workstation or work-areas have ESD signs?
- 8.7.2.2. All surfaces and objects at all static-safe workstation and within 1 ft measure less than 100V?
- 8.7.2.3. All ionizer activated, positioned towards the units?
- 8.7.2.4. Each work surface mats grounding is good?

Personnel Grounding

- 8.7.3.1. Every person (including visitors) handling ESD sensitive (ESDS) items wear wrist strap, heel strap or conductive shoes with conductive flooring?
- 8.7.3.1. If conductive footwear used, conductive flooring also present where operator stand or walk?
- 8.7.3.2. Garments, hairs or anything closer than 1 ft to ESD items measure less than 100V*?
- 8.7.3.3. Every wrist strap or heel strap/conductive shoes checked daily and result recorded for all DLs?
- 8.7.3.4. All wrist strap or heel strap checkers calibration up to date?

Note: *50V for Blue LED.

Device Handling

- 8.7.4.1. Every ESDS items identified by EIA-471 labels on item or packaging?
- 8.7.4.2. All ESDS items completely inside properly closed static-shielding containers when not at static-safe workstation?
- 8.7.4.3. No static charge generators (e.g. plastics) inside shielding containers with ESDS items?
- 8.7.4.4. All flexible conductive and dissipative package materials inspected before reuse or recycle?

Others

- 8.7.5.1. Audit result reported to entity ESD control coordinator?
- 8.7.5.2. Corrective action from previous audits completed?
- 8.7.5.3. Are audit records complete and on file?

Through Hole Lamp LTLR1DEKVJNNH155T

9. Reliability Test

Classification	Test Item	Test Condition	Sample Size	Reference Standard
Endurance Test	Operation Life	Ta = Under room temperature IF = per datasheet maximum drive current Test Time= 1000hrs	22 PCS (CL=90%; LTPD=10%)	MIL-STD-750D:1026 (1995) MIL-STD-883G:1005 (2006)
	High Temperature High Humidity storage	Ta = 60°C RH = 90% Test Time= 240hrs	22 PCS (CL=90%; LTPD=10%)	MIL-STD-202G:103B (2002) JEITA ED-4701:100 103 (2001)
	High Temperature Storage	Ta= 105 ± 5°C Test Time= 1000hrs	22 PCS (CL=90%; LTPD=10%)	MIL-STD-750D:1031 (1995) MIL-STD-883G:1008 (2006) JEITA ED-4701:200 201 (2001)
	Low Temperature Storage	Ta= -55 ± 5°C Test Time= 1000hrs	22 PCS (CL=90%; LTPD=10%)	JEITA ED-4701:200 202 (2001)
Environmental Test	Temperature Cycling	100°C ~ 25°C ~ -40°C ~ 25°C 30mins 5mins 30mins 5mins 30 Cycles	22 PCS (CL=90%; LTPD=10%)	MIL-STD-750D:1051 (1995) MIL-STD-883G:1010 (2006) JEITA ED-4701:100 105 (2001) JESD22-A104C (2005)
	Thermal Shock	100 ± 5°C ~ -30°C ± 5°C 15mins 15mins 30 Cycles (<20 secs transfer)	22 PCS (CL=90%; LTPD=10%)	MIL-STD-750D:1056 (1995) MIL-STD-883G:1011 (2006) MIL-STD-202G:107G (2002) JESD22-A106B (2004)
	Solder Resistance	T.sol = 260 ± 5°C Dwell Time= 10±1 seconds 3mm from the base of the epoxy bulb	11 PCS (CL=90%; LTPD=18.9%)	MIL-STD-750D:2031(1995) JEITA ED-4701: 300 302 (2001)
	Solderability	T. sol = 245 ± 5°C Dwell Time= 5 ± 0.5 seconds (Lead Free Solder, Coverage ≥ 95% of the dipped surface)	11 PCS (CL=90%; LTPD=18.9%)	MIL-STD-750D:2026 (1995) MIL-STD-883G:2003 (2006) MIL-STD-202G:208H (2002) IPC/EIA J-STD-002 (2004)
	Soldering Iron	T. sol = 350 ± 5°C Dwell Time= 3.5 ± 0.5 seconds	11 PCS (CL=90%; LTPD=18.9%)	MIL-STD-202G:208H (2002) JEITA ED-4701:300 302 (2001)

10. Others

The appearance and specifications of the product may be modified for improvement, without prior notice.