

## *EL ALFS Series*

### ALFS3J-C010001H-AM



### Features

- Package : SMD ceramic package
- Typ. Luminance Flux : 1275 lm @ 1000mA
- Viewing angle : 120°
- ESD : up to 8KV
- MSL : 2
- Qualifications : According to AEC-Q102
- Sulfur robustness : Class A1
- The product itself will remain within RoHS compliant version.
- Compliance with EU REACH.
- Compliance Halogen Free .(Br <900 ppm ,Cl <900 ppm , Br+Cl < 1500 ppm).

### Applications

- Automotive Exterior Lighting
- Headlamp
- Daytime running light (DRL)
- Fog lamp

# Contents

1. Characteristics .....	3
2. Absolute Maximum Ratings .....	4
3. Characteristics Graph .....	5
4. Binning Information .....	10
5. Part Number.....	14
6. Ordering Information .....	15
7. Mechanical Dimension.....	16
8. Recommended Soldering Pad.....	17
9. Reflow Soldering Profile.....	18
10. Packaging Information.....	19
11. Precaution for Use .....	21
12. Sulfur Test Criteria .....	22

# 1. Characteristics

Parameter	Symbol	Min.	Typ.	Max.	Unit	Condition
Forward Current <sup>[4]</sup>	$I_F$	50	1000	1500	mA	---
Luminous Flux <sup>[1][2]</sup>	$\Phi_v$	1200	1275	1500	lm	$I_F=1000\text{mA}$
Forward Voltage <sup>[3]</sup>	$V_F$	8.70	9.90	11.40	V	$I_F=1000\text{mA}$
Viewing Angle	$\varphi$	---	120	---	deg	$I_F=1000\text{mA}$
Color	K	5391	---	6893	K	$I_F=1000\text{mA}$
Thermal Resistance (Junction to Solder)	$R_{th\ JS\ real}$	---	2.3	2.7	K/W	$I_F=1000\text{mA}$
	$R_{th\ JS\ el}$	---	1.6	2.0		

## Notes:

1. Luminous Flux measurement tolerance:  $\pm 8\%$ .
2. The data of Luminous Flux measured at thermal pad= $25^\circ\text{C}$
3. Forward voltage measurement tolerance:  $\pm 0.05\text{V}$
4. Current pulse time: 25ms

## 2. Absolute Maximum Ratings

Parameter	Symbol	Ratings	Unit
Power Dissipation	$P_d$	17100	mW
Forward Current	$I_F$	1500	mA
Reverse Voltage	$V_R$	Not designed for reverse operation	V
Junction Temperature	$T_J$	150	°C
Operating Temperature	$T_{opr}$	-40 ~ +125	°C
Storage Temperature	$T_{stg}$	-40 ~ +125	°C
ESD Sensitivity (R=1.5k $\Omega$ , C= 100pF)	ESD <sub>HBM</sub>	8	kV
Soldering Temperature	Reflow	260	°C

### 3. Characteristics Graph

**Wavelength Characteristics Relative Spectral Distribution**  
 @  $T_s = 25^\circ\text{C}$ ,  $I_f = 1000\text{mA}$

$$\Phi_v / \Phi_v(\text{Max.}) = f(\lambda)$$

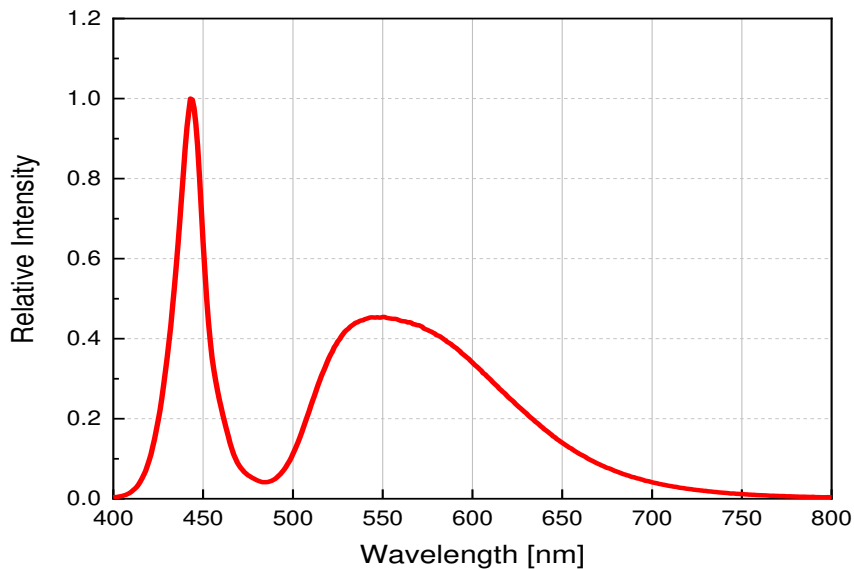

**Typical Diagram Characteristics of Radiation**

$$\Phi_v / \Phi_v(0^\circ) = f(\varphi)$$

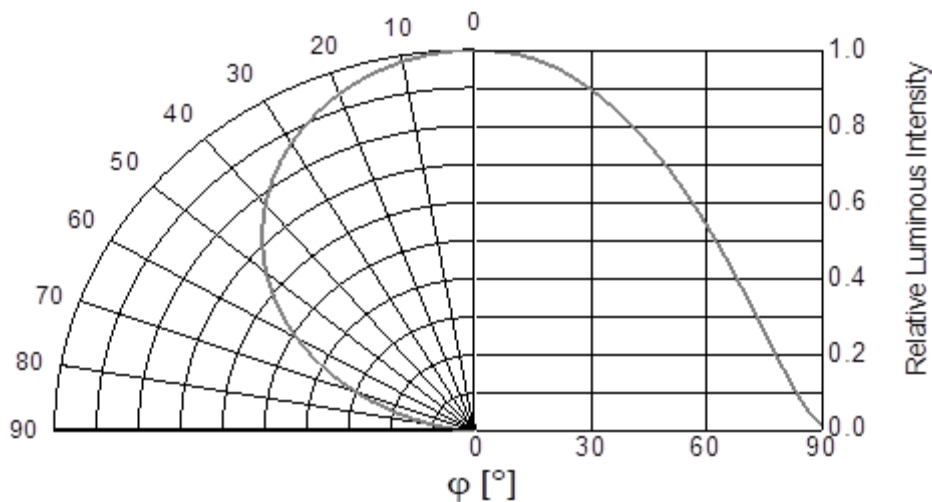

**Notes:**

1.  $\varphi$  is the off axis angle from lamp centerline where the luminous intensity is 1/2 of the peak value.
2. View angle tolerance is  $\pm 5^\circ$ .

### Forward Current vs. Forward Voltage

@ Ts = 25°C

$$I_F = f(V_F)$$

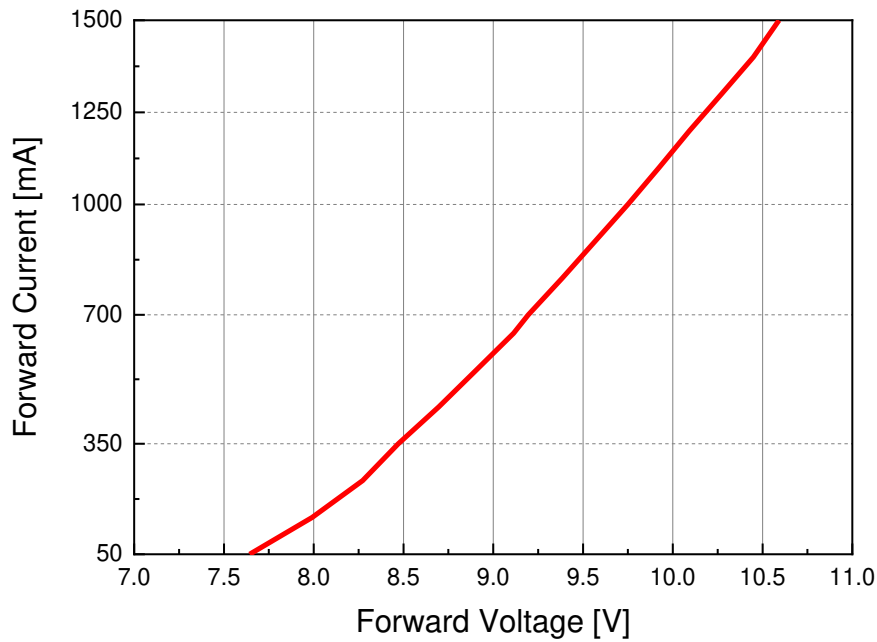

### Relative Luminous Intensity vs. Forward Current

@ Ts = 25°C

$$\Phi_V / \Phi_V(1000mA) = f(I_F)$$

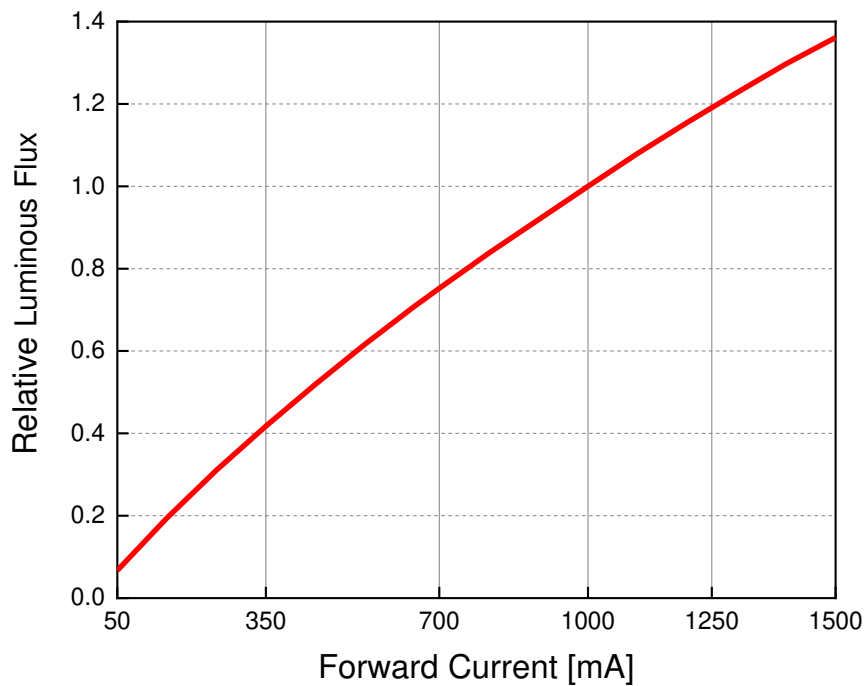

### Chromaticity Coordinates Shift vs. Forward Current @ Ts = 25°C

$$\Delta CIE\ x, \Delta CIE\ y = f(I_F)$$

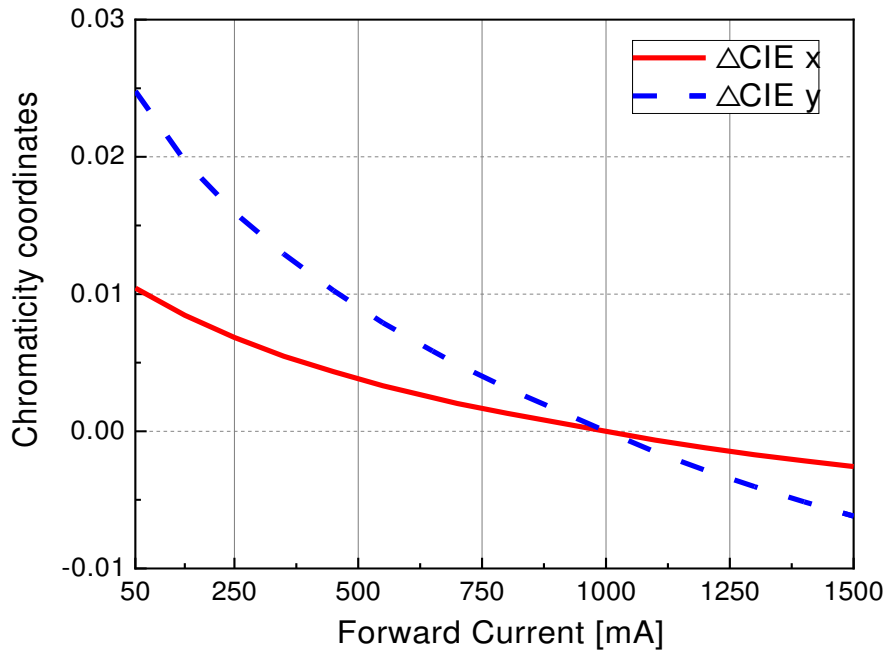

### Relative Forward Voltage vs. Junction Temperature @ IF=1000mA

$$\Delta V_F = V_F - V_F(25^\circ C) = f(T_j)$$

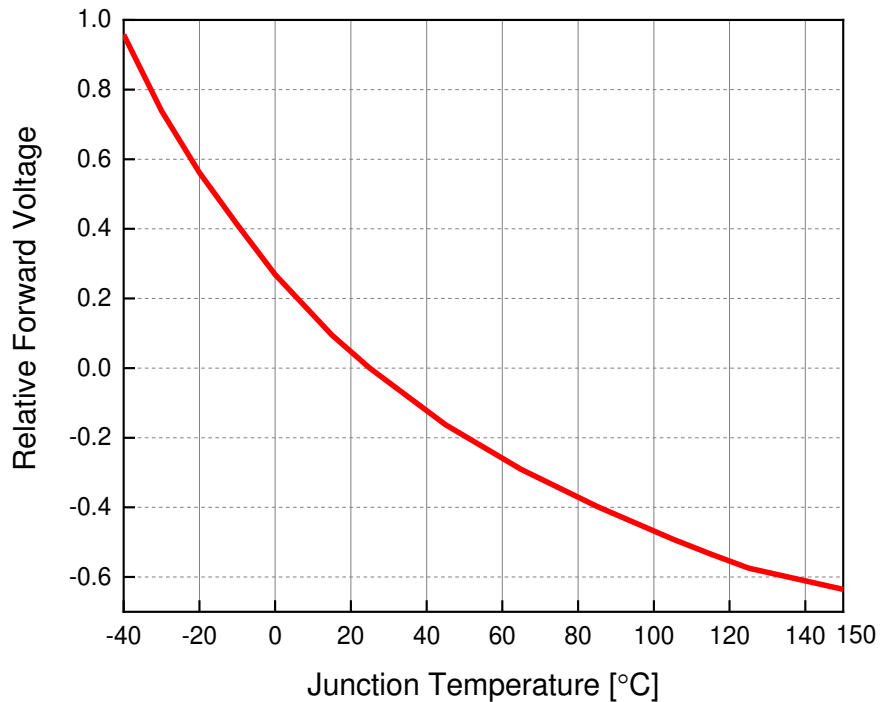

### Relative Luminous Intensity vs. Junction Temperature

@  $I_F=1000\text{mA}$

$$\Phi_V / \Phi_V(25^\circ\text{C}) = f(T_j)$$

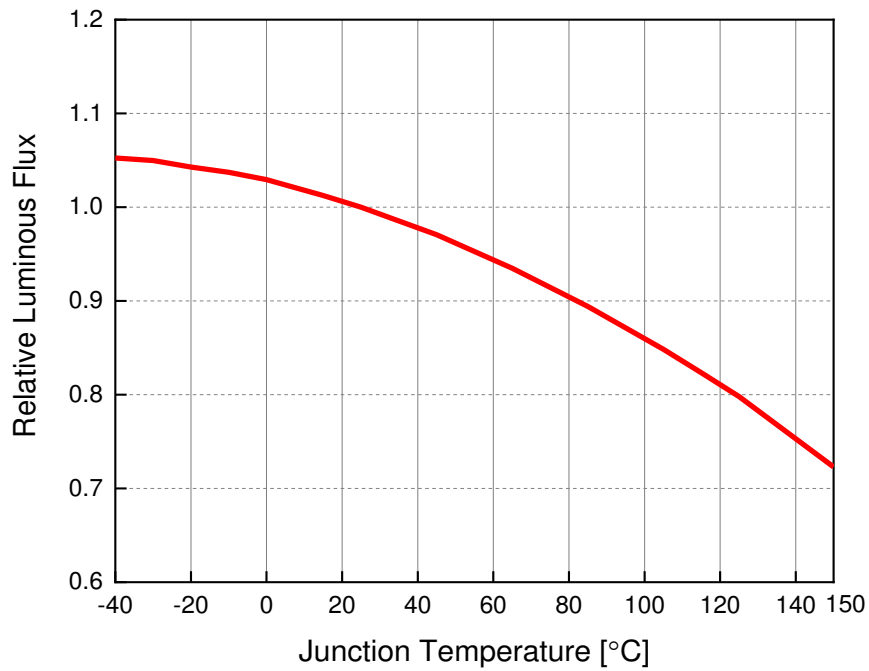

### Chromaticity Coordinates Shift vs. Junction Temperature

@  $I_F=1000\text{mA}$

$$\Delta \text{CIE } x, \Delta \text{CIE } y = f(T_j)$$

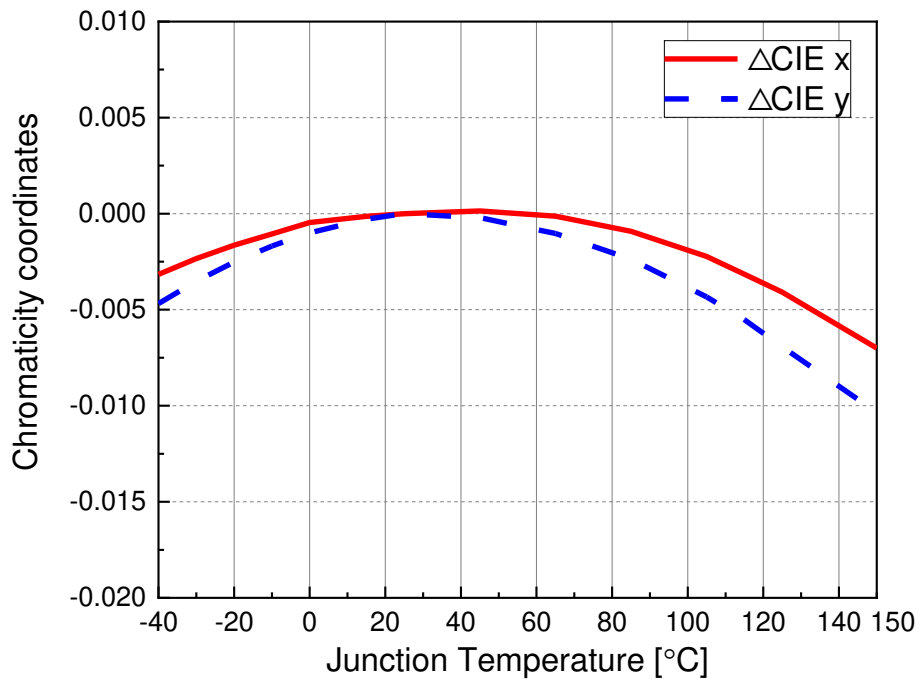

## Forward Current Derating Curve

$$I_F = f(T_s)$$

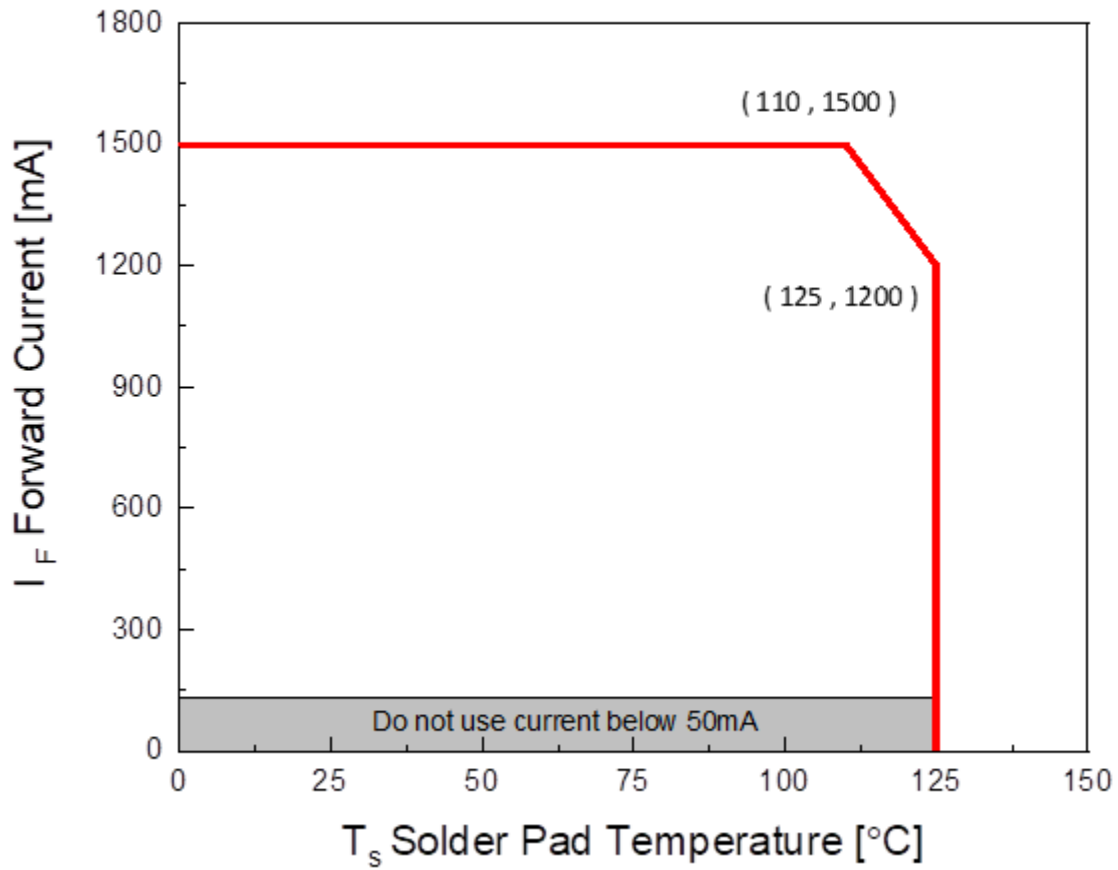

## 4. Binning Information

### Luminous Intensity Bins

Group Bin	Bin	Minimum Luminous Flux (lm)	Maximum Luminous Flux (lm)
E	3	1200	1275
	4	1275	1350
	5	1350	1425
	6	1425	1500

#### Notes:

1. Luminous flux measurement tolerance:  $\pm 8\%$ .
2. Test current: Typical forward current.
3. Current pulse time: 25ms

### Forward Voltage Bins

Bin code	Min Forward Voltage [V]	Max Forward Voltage [V]
3A	8.70	9.60
3B	9.60	10.50
3C	10.50	11.40

#### Notes:

1. Forward Voltage measurement tolerance:  $\pm 0.05V$ .
2. Test current: Typical forward current
3. Current pulse time: 25ms

## Color Bin Structure ECE Bin Structure

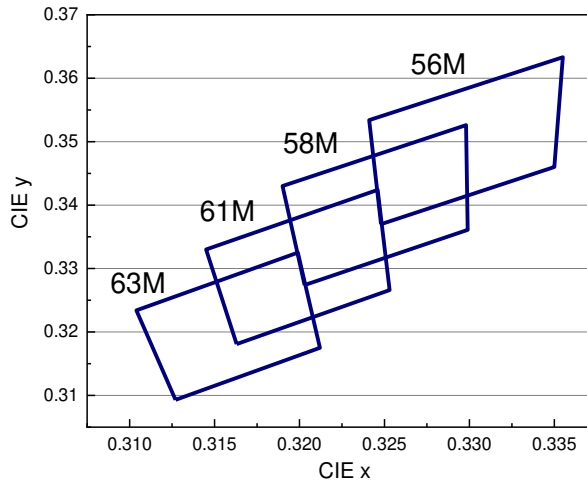
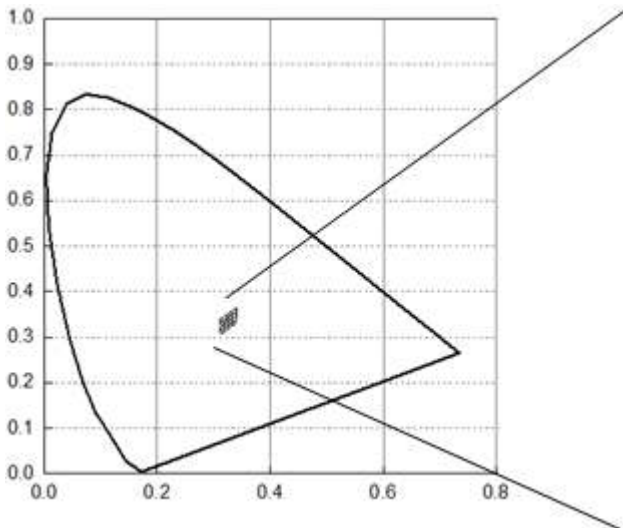

### Cool White Bin Coordinates

Bin	CIE x	CIE y
63M	0.3127	0.3093
	0.3212	0.3175
	0.3199	0.3325
	0.3104	0.3234

Bin	CIE x	CIE y
61M	0.3163	0.3181
	0.3253	0.3266
	0.3246	0.3424
	0.3145	0.3330

Bin	CIE x	CIE y
58M	0.3203	0.3274
	0.3299	0.3361
	0.3298	0.3526
	0.319	0.343

Bin	CIE x	CIE y
56M	0.3248	0.337
	0.335	0.346
	0.3355	0.3633
	0.3241	0.3534

**Notes:**

1. Color coordinates measurement tolerance:  $\pm 0.005$
2. Test current: Typical forward current.
3. Current pulse time: 25ms

### Color Bin Structure

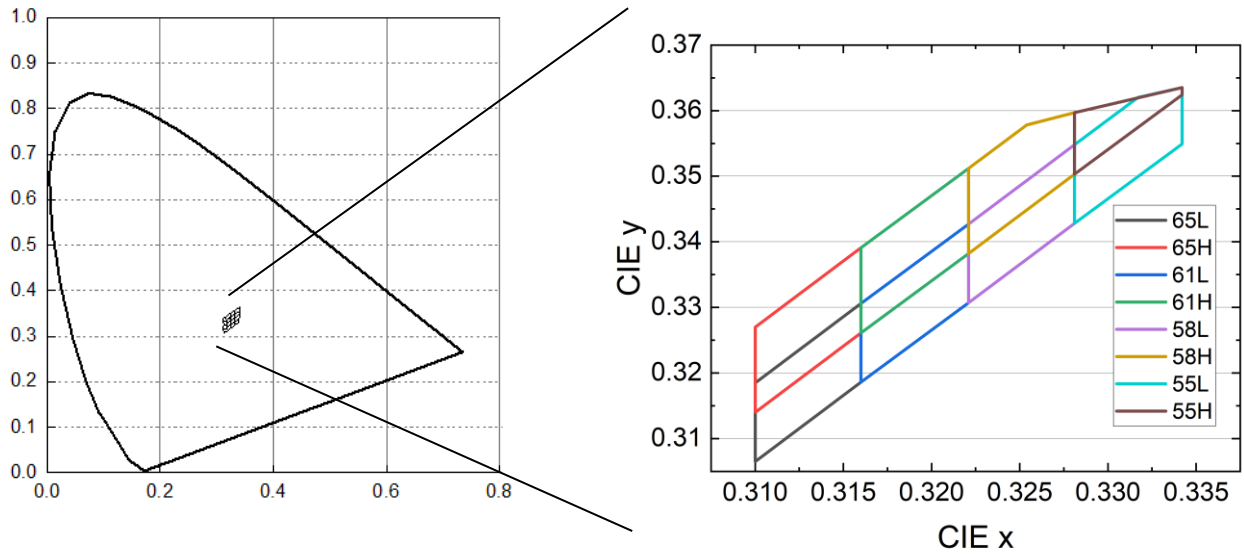

### Cool White Bin Coordinates

Bin	CIE x	CIE y
65L	0.3100	0.3065
	0.3100	0.3185
	0.3160	0.3306
	0.3160	0.3186

Bin	CIE x	CIE y
65H	0.3100	0.3140
	0.3100	0.3270
	0.3160	0.3391
	0.3160	0.3261

Bin	CIE x	CIE y
61L	0.3160	0.3186
	0.3160	0.3306
	0.3221	0.3427
	0.3221	0.3307

Bin	CIE x	CIE y
61H	0.3160	0.3261
	0.3160	0.3391
	0.3221	0.3512
	0.3221	0.3382

Bin	CIE x	CIE y
58L	0.3221	0.3307
	0.3221	0.3427
	0.3281	0.3548
	0.3281	0.3428

Bin	CIE x	CIE y
58H	0.3221	0.3382
	0.3221	0.3512
	0.3254	0.3578
	0.3281	0.3597
	0.3281	0.3503

Bin	CIE x	CIE y
55L	0.3281	0.3428
	0.3281	0.3548
	0.3317	0.3620
	0.3342	0.3635
	0.3342	0.3549

Bin	CIE x	CIE y
55H	0.3281	0.3503
	0.3281	0.3597
	0.3342	0.3635
	0.3342	0.3624

**Notes:**

1. Color coordinates measurement tolerance:  $\pm 0.005$
2. Test current: Typical forward current
3. Current pulse time: 25ms

## 5. Part Number

### ALFS3J-C010001H-AM

Part number is designated with below details.

ALFS = Product family name.

3 = chip number

H = Product type

C = Color<sup>[1]</sup>

0 = CRI (N/A=0 ; >70=7 ; >80=8 ; >90=9)

1000 = Test current [mA]

1 = internal code

H = Brightness Level

AM = Automotive application

Note

[1] Color :

Symbol	Description
C	Cool White
N	Neutral White
W	Warm White
PA	Phosphor Converted Amber
PR	Phosphor Converted Red
UB	Blue
IB	Ice Blue
SB	Sky Blue
UP	Purple
UG	Green
UY	Yellow
UYG	Brilliant Yellow Green
UPG	Pale Green
UA	Amber
UR	Red
SR	Super Red
RGB	RGB-Color

## 6. Ordering Information

### ALFS3J-C010001H-**ABCDEFGHIJKLMN-OP-AM**

Part Number of the ALFS1H	Order Code
ALFS3J-C010001H-AM	ALFS3J-C010001H- <b>ABCDEFGHIJKLMN-OP-AM</b>

Order code contains information with below details :

**ABCDEF** = min/max wavelength or CCT

**GHIJ** = min./max. luminous flux in [lm] or luminous intensity in [mcd]

**KLMN** = min./max. forward voltage

**OP** = internal code

**AM** = Automotive Application

# 7. Mechanical Dimension

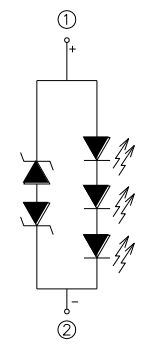
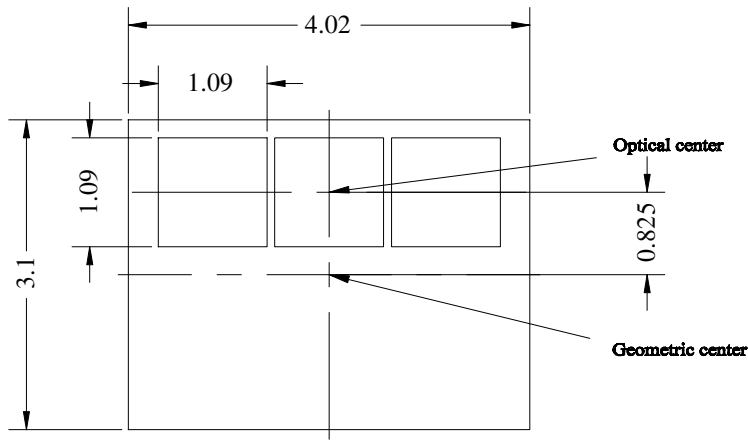

Polarity

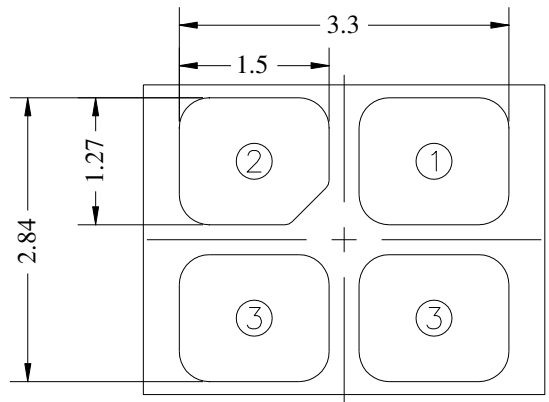
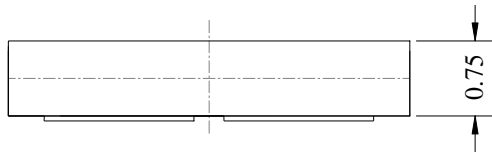

①	Anode
②	Cathode
③	Thermal pad

**Notes:**

- 1. Dimensions are in millimeters.
- 2. Tolerances unless mentioned are  $\pm 0.1$ mm.

# 8. Recommended Soldering Pad

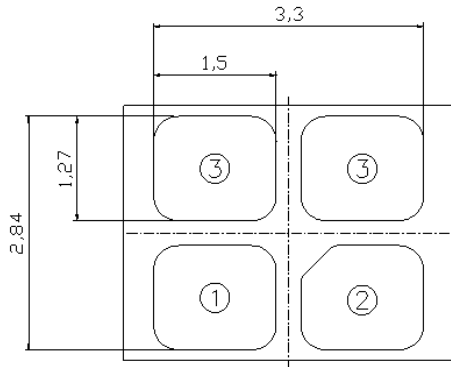

Bottom view

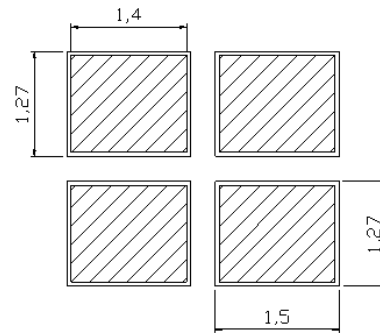
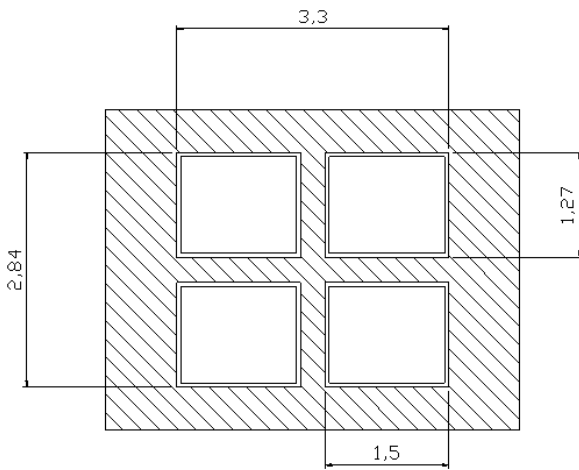

 solder resist

 solder stencil (Unit : mm)

# 9. Reflow Soldering Profile

Soldering Condition (Reference: IPC/JEDEC J-STD-020D)

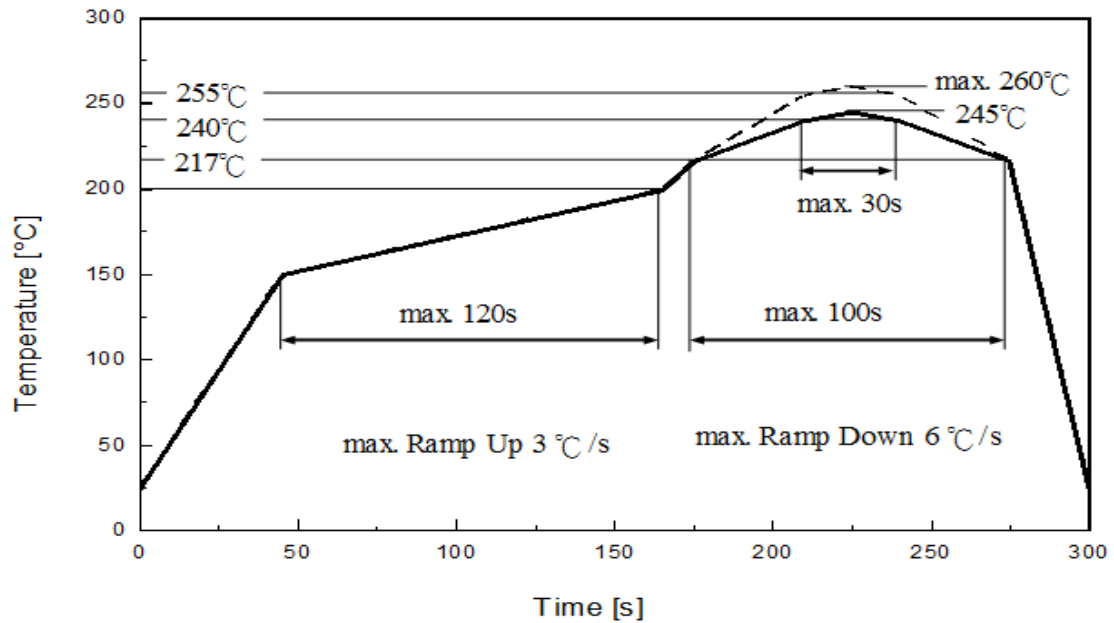

Profile Feature	Pb-Free Assembly	Unit
	Recommendation	
Ramp-up rate to preheat 25 °C to 150 °C	3	°C /sec
Time of soaking zone 150 °C to 200 °C	120	sec
Ramp-up rate to peak	3	°C /sec
Liquidus temperature	217	°C
Time above liquidus temperature	100	sec
Peak temperature (max.)	260	°C
Time within 5°C of the specified peak temperature	30	sec
Ramp-down Rate (max.)	6	°C /sec

# 10. Packaging Information

## • Product Labeling



- CPN : Customer's Product Number
- P/N : Everlight Part Number
- LOT No : Lot Number
- QTY : Packing Quantity
- HUE : Color Bin
- CAT : Luminous Flux (Brightness) Bin
- REF : Forward Voltage Bin

## • Carrier Tape Dimensions as the following

Reel: 1000pcs, MOQ>100pcs(has to be a multiple of 100pcs)

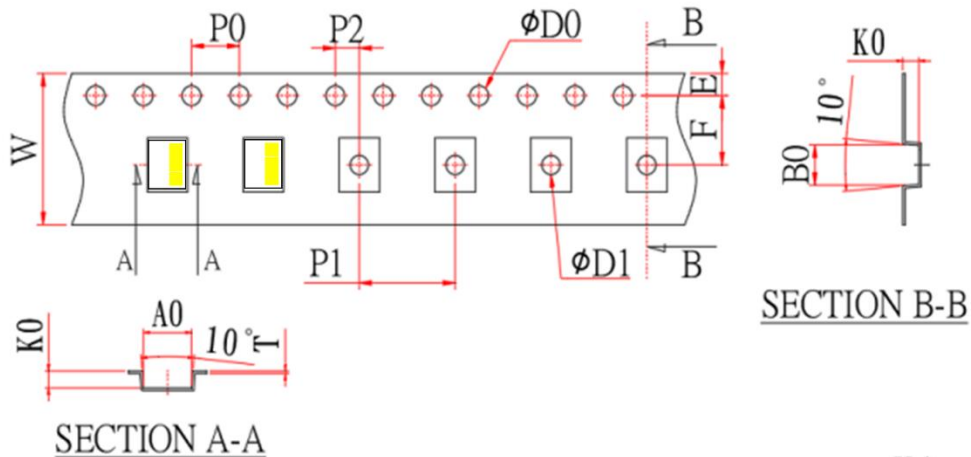

Unit:mm

ITEM	Ao	Bo	Ko	Po	P1	P2	Do	D1	E	F	W	T	10Po
DIM	3.35	4.30	0.65	4.0	8.0	2.0	1.50	1.50	1.75	5.50	12.0	0.20	40.0
TOLE	±0.05	±0.05	±0.05	±0.10	±0.10	±0.05	+0.1 0	MIN	±0.10	±0.10	±0.10	±0.03	±0.20

### Notes:

1. Dimensions are in millimeters.

● Reel Dimensions

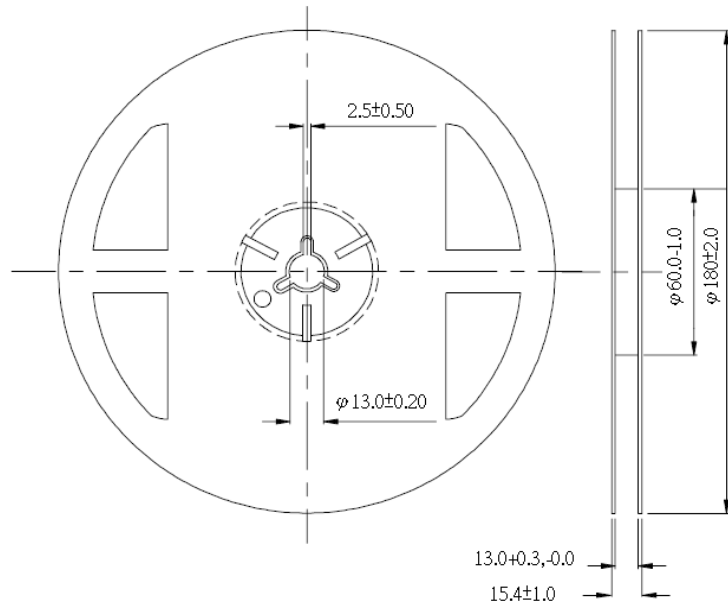

Notes:

1. Dimensions are in millimeters.

● Moisture Resistant Packing Process

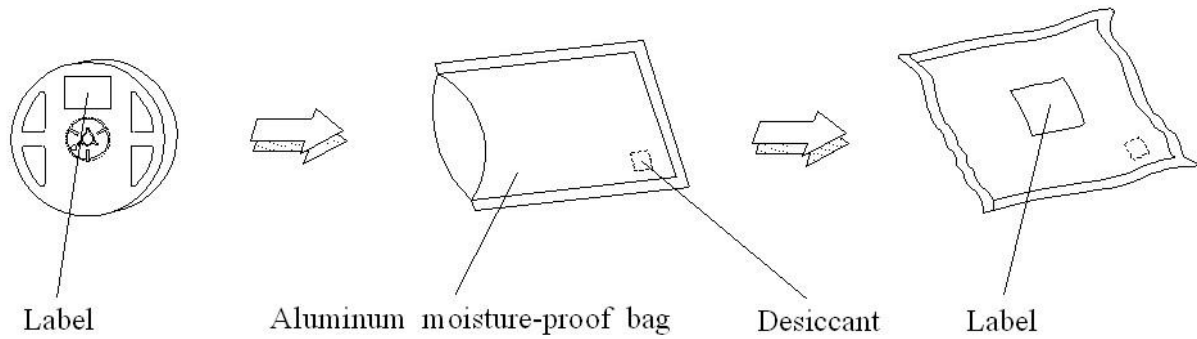

## 11. Precaution for Use

### 1. Over-current-proof

Customer must apply resistors for protection; otherwise slight voltage shift will cause big current change (burn out will happen).

### 2. Assemblies

Do not stack assemblies containing LEDs to prevent damage to the optical surface of LEDs. Forces applied to the optical surface may result in the surface being damaged.

### 3. Soldering Condition

3.1 When soldering, do not put stress on the LEDs during heating.

3.2 After soldering, do not warp the circuit board.

### 4. Soldering Iron

Each terminal is to go to the tip of soldering iron temperature less than 350°C for 3 seconds within once in less than the soldering iron capacity 25W. Leave two seconds and more intervals, and do soldering of each terminal. Be careful because the damage of the product is often started at the time of the hand solder.

### 5. Repairing

Repair should not be done after the LEDs have been soldered. When repairing is unavoidable, a double-head soldering iron should be used (as below figure). It should be confirmed beforehand whether the characteristics of the LEDs will or will not be damaged by repairing.

## 12. Sulfur Test Criteria

Products	Failure Criteria
Exterior Lighting products	Luminous Flux +/-20%, forward voltage +/-10%, color coordinates x,y +/-0.01, color wavelength +/- 2 nm Visual defect issue following Everlight's inspection criteria
Interior lighting products	Luminous Flux +/-30% or +/-50% for some application, forward voltage +/-10%, color coordinates x,y +/-0.02, color wavelength +/- 2 nm Visual defect issue following Everlight's inspection criteria
Grade of H2S and FMG test	Please refer to the table as below. As for discolor, please refer to the Frame blackening after Grade of H2S and FMG test defect under Everlight's inspection criteria

H2S test	Grade A0	Grade A1	Grade B0	Grade B1
Class A	Pass $\Delta IV$ , $\Delta Color$ , $\Delta VF$ criteria No discoloration	Pass $\Delta IV$ , $\Delta Color$ , $\Delta VF$ criteria Discoloration		
Class B			Pass $\Delta IV$ , $\Delta Color$ , $\Delta VF$ criteria No discoloration	Pass $\Delta IV$ , $\Delta Color$ , $\Delta VF$ criteria Discoloration

Class for H2S Test & FMG	Description	
	H2S	FMG
Class A	15 ppm with duration 336 h at 40 °C and 90% RH.	Duration 500 h at 25 °C and 75% RH. H2S concentration: 10ppb SO2 concentration: 200ppb NO2 concentration: 200ppb Cl2 concentration: 10ppb
Class B	10 ppm with duration 500 h at 25 °C and 75% RH.	

Grade for H2S Test	Description
0	No discoloration
1	Discoloration

# Revision History

Current version : July, 18, 2025

Issue No: DHE-0004359

Version: 4

Created by: Chris Chuang

<b>Rev.</b>	<b>Subjects (major change in previous version)</b>	<b>Modified date</b>
1	Standard data sheet	2023/11/29
2	Revise CIE BIN Data	2024/05/30
3	Revise textual errors	2024/12/9
4	Update Color	2025/7/18