

8 PIN DIP HIGH SPEED 10MBit/s LOGIC GATE PHOTOCOUPLER 6N137 EL26XX series

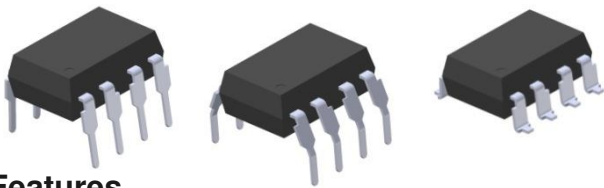

Features

- High speed 10Mbit/s
- 10kV/ μ s min. common mode transient immunity (EL2611)
- Guaranteed performance from -40 to 85°C
- Logic gate output
- High isolation voltage between input and output (Viso=5000 V rms)
- Pb free and RoHS compliant.
- UL and cUL approved(No. E214129)
- VDE approved (No. 132249)
- SEMKO approved
- NEMKO approved
- DEMKO approved
- FIMKO approved

Schematic

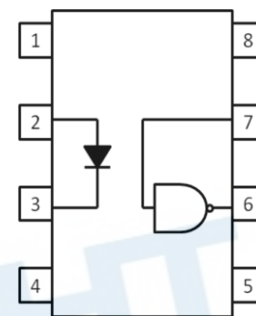

A 0.1 μ F bypass capacitor must be connected between pins 8 and 5 *3

Pin Configuration

- 1, No Connection
- 2, Anode
- 3, Cathode
- 4, No Connection
- 5, Gnd
- 6, V_{out}
- 7, V_E
- 8, V_{CC}

Description

The 6N137, EL2601 and EL2611 are consists of an infrared emitting diode optically coupled to a high speed integrated photo detector logic gate with a strobable output. It is packaged in a 8-pin DIP package and available in wide-lead spacing and SMD options.

Applications

- Ground loop elimination
- LSTTL to TTL, LSTTL or 5 volt CMOS
- Line receiver, data transmission
- Data multiplexing
- Switching power supplies
- Pulse transformer replacement
- Computer peripheral interface
- High speed logic ground isolation

Truth Table (Positive Logic)

| Input | Enable | Output |
|-------|--------|--------|
| H | H | L |
| L | H | H |
| H | L | H |
| L | L | H |
| H | NC | L |
| L | NC | H |

Absolute Maximum Ratings (Ta=25°C)

| | Parameter | Symbol | Rating | Unit |
|--------|---|-----------|------------|-------|
| Input | Forward current | I_F | 50 | mA |
| | Enable input voltage Not exceed V_{CC} by more than 500mV | V_E | 5.5 | V |
| | Reverse voltage | V_R | 5 | V |
| | Power dissipation | P_D | 100 | mW |
| Output | Power dissipation | P_C | 85 | mW |
| | Output current | I_O | 50 | mA |
| | Output voltage | V_O | 7.0 | V |
| | Supply voltage | V_{CC} | 7.0 | V |
| | Output Power Dissipation | P_O | 100 | mW |
| | Isolation voltage ^{*1} | V_{ISO} | 5000 | V rms |
| | Operating temperature | T_{OPR} | -40 ~ +85 | °C |
| | Storage temperature | T_{STG} | -55 ~ +125 | °C |
| | Soldering temperature ^{*2} | T_{SOL} | 260 | °C |

Notes:

*1 AC for 1 minute, R.H.= 40 ~ 60% R.H. In this test, pins 1, 2, 3 & 4 are shorted together, and pins 5, 6, 7 & 8 are shorted together.

*2 For 10 seconds.

Electrical Characteristics (Ta=-40 to 85°C unless specified otherwise)**Input**

| Parameter | Symbol | Min. | Typ. | Max. | Unit | Condition |
|--|-------------------------|------|------|------|-------|------------------------|
| Forward voltage | V_F | - | 1.4 | 1.8 | V | $I_F = 10\text{mA}$ |
| Reverse voltage | V_R | 5.0 | - | - | V | $I_R = 10\mu\text{A}$ |
| Temperature coefficient of forward voltage | $\Delta V_F/\Delta T_A$ | - | -1.8 | - | mV/°C | $I_F = 10\text{mA}$ |
| Input capacitance | C_{IN} | - | 60 | - | pF | $V_F=0, f=1\text{MHz}$ |

Output

| Parameter | Symbol | Min | Typ. | Max. | Unit | Condition |
|---------------------------------------|-----------|-----|------|------|------|---|
| High level supply current | I_{CCH} | - | 7 | 10 | mA | $I_F=0\text{mA}, V_E=0.5\text{V}, V_{CC}=5.5\text{V}$ |
| Low level supply current | I_{CCL} | - | 9 | 13 | mA | $I_F=10\text{mA}, V_{CC}=5.5\text{V}$ |
| High level enable current | I_{EH} | - | -0.6 | -1.6 | mA | $V_E=2.0\text{V}, V_{CC}=5.5\text{V}$ |
| Low level enable current | I_{EL} | - | -0.8 | -1.6 | mA | $V_E=0.5\text{V}, V_{CC}=5.5\text{V}$ |
| High level enable voltage | V_{EH} | 2.0 | - | - | V | $I_F=10\text{mA}, V_{CC}=5.5\text{V}$ |
| Low level enable voltage ⁴ | V_{EL} | - | - | 0.8 | V | $I_F=10\text{mA}, V_{CC}=5.5\text{V}$ |

Transfer Characteristics (Ta=-40 to 85°C unless specified otherwise)

| Parameter | Symbol | Min | Typ. | Max. | Unit | Condition |
|---------------------------|----------|-----|------|------|---------------|--|
| HIGH Level Output Current | I_{OH} | - | 2.1 | 100 | μA | $V_{CC}=5.5\text{V}, V_O=5.5\text{V}, I_F=250\mu\text{A}, V_E=2.0\text{V}$ |
| LOW Level Output Current | V_{OL} | - | 0.35 | 0.6 | V | $V_{CC} = 5.5\text{V}, I_F=5\text{mA}, V_E=2.0\text{V}, I_{CL}=13\text{mA}$ |
| Input Threshold Current | I_{FT} | - | 2.5 | 5 | mA | $V_{CC}= 5.5\text{V}, V_O=0.6\text{V}, V_E =2.0\text{V}, I_{OL}=13\text{mA}$ |

Switching Characteristics ($T_a=-40$ to 85°C , $V_{CC}=5\text{V}$, $I_F=7.5\text{mA}$ unless specified otherwise)

| Parameter | Symbol | Min | Typ. | Max. | Unit | Condition |
|---|-----------------------|-----|------|------|------|---|
| Propagation delay time to output High level* ⁵ (Fig.12) | T_{PHL} | - | 35 | 75 | ns | $C_L = 15\text{pF}$, $R_L=350\Omega$, $T_A=25^\circ\text{C}$ |
| Propagation delay time to output Low level* ⁶ (Fig.12) | T_{PLH} | - | 40 | 75 | ns | $C_L = 15\text{pF}$, $R_L=350\Omega$, $T_A=25^\circ\text{C}$ |
| Pulse width distortion | $ T_{phl} - T_{plh} $ | - | 5 | 35 | ns | $C_L = 15\text{pF}$, $R_L=350\Omega$ |
| Output rise time* ⁷ (Fig.12) | tr | - | 40 | - | ns | $C_L = 15\text{pF}$, $R_L=350\Omega$ |
| Output fall time* ⁸ (Fig.12) | tf | - | 10 | - | ns | $C_L = 15\text{pF}$, $R_L=350\Omega$ |

Switching Characteristics ($T_a=-40$ to 85°C , $V_{CC}=5\text{V}$, $I_F=7.5\text{mA}$ unless specified otherwise)

| Parameter | Symbol | Min | Typ. | Max. | Unit | Condition |
|--|-----------|--------|------|------|-----------------|---|
| Enable Propagation Delay Time to Output High Level* ⁹ (Fig.13) | t_{ELH} | - | 15 | - | ns | $I_F = 7.5\text{mA}$, $V_{EH}=3.5\text{V}$, $C_L = 15\text{pF}$, $R_L=350\Omega$ |
| Enable Propagation Delay Time to Output Low Level* ¹⁰ (Fig.13) | t_{EHL} | - | 15 | - | ns | $I_F = 7.5\text{mA}$, $V_{EH}=3.5\text{V}$, $C_L = 15\text{pF}$, $R_L=350\Omega$ |
| | 6N137 | - | - | - | | $I_F = 0\text{mA}$, $V_{OH}=2.0\text{V}$, $R_L=350\Omega$, $T_A=25^\circ\text{C}$ $V_{CM}=10\text{Vp-p}$ (Fig.14) |
| Common Mode Transient Immunity at Logic High* ¹¹ | EL2601 | 5,000 | - | - | $V/\mu\text{S}$ | $I_F = 0\text{mA}$, $V_{OH}=2.0\text{V}$, $R_L=350\Omega$, $T_A=25^\circ\text{C}$ $V_{CM}=50\text{Vp-p}$ (Fig.14) |
| | EL2611 | 10,000 | - | - | | $I_F = 0\text{mA}$, $V_{OH}=2.0\text{V}$, $R_L=350\Omega$, $T_A=25^\circ\text{C}$ $V_{CM}=400\text{Vp-p}$ (Fig.14) |
| | EL2611 | 20,000 | - | - | | $I_F = 0\text{mA}$, $V_{OH}=2.0\text{V}$, $R_L=350\Omega$, $T_A=25^\circ\text{C}$ $V_{CM}=400\text{Vp-p}$ (Fig.15) |
| | 6N137 | - | - | - | | $I_F = 7.5\text{mA}$, $V_{OL}=0.8\text{V}$, $R_L=350\Omega$, $T_A=25^\circ\text{C}$ $V_{CM}=10\text{Vp-p}$ (Fig.14) |
| Common Mode Transient Immunity at Logic Low* ¹² | EL2601 | 5,000 | - | - | $V/\mu\text{S}$ | $I_F = 7.5\text{mA}$, $V_{OL}=0.8\text{V}$, $R_L=350\Omega$, $T_A=25^\circ\text{C}$ $V_{CM}=50\text{Vp-p}$ (Fig.14) |
| | EL2611 | 10,000 | - | - | | $I_F = 7.5\text{mA}$, $V_{OL}=0.8\text{V}$, $R_L=350\Omega$, $T_A=25^\circ\text{C}$ $V_{CM}=400\text{Vp-p}$ (Fig.14) |
| | EL2611 | 20,000 | - | - | | $I_F = 7.5\text{mA}$, $V_{OH}=0.8\text{V}$, $R_L=350\Omega$, $T_A=25^\circ\text{C}$ $V_{CM}=400\text{Vp-p}$ (Fig.15) |
| | 6N137 | - | - | - | | $I_F = 7.5\text{mA}$, $V_{OH}=0.8\text{V}$, $R_L=350\Omega$, $T_A=25^\circ\text{C}$ $V_{CM}=400\text{Vp-p}$ (Fig.15) |

Typical Electro-Optical Characteristics Curves

Fig.1 Input Diode Forward Voltage vs. Forward Current

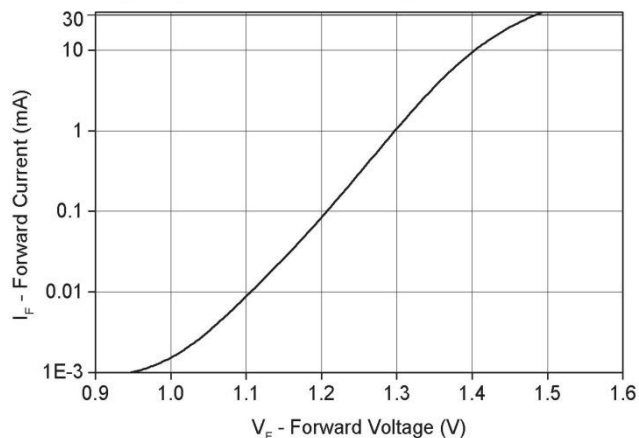

Fig.2 Low Level Output Voltage vs. Ambient Temperature

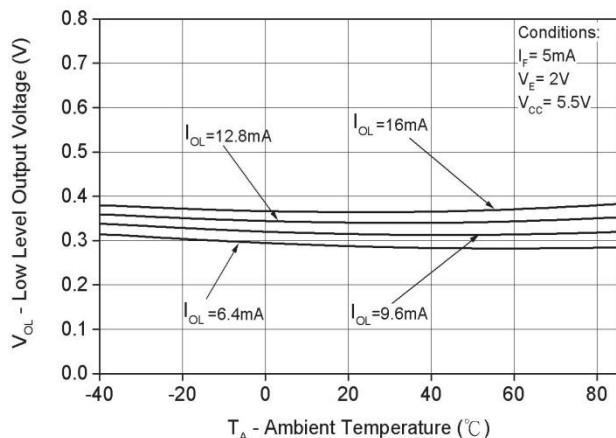

Fig.3 Low Level Output Current vs. Ambient Temperature

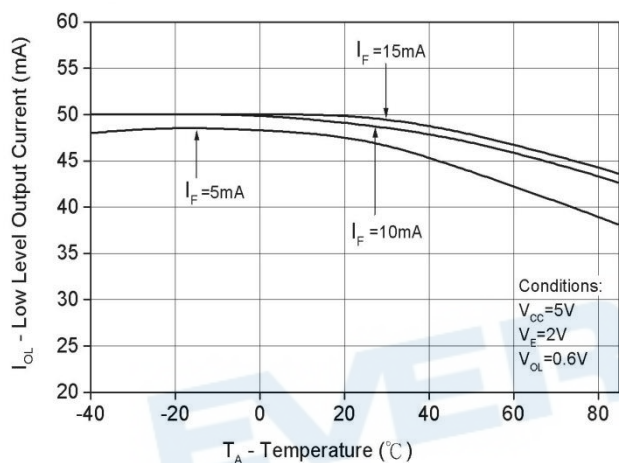

Fig.4 Input Threshold Current vs. Ambient Temperature

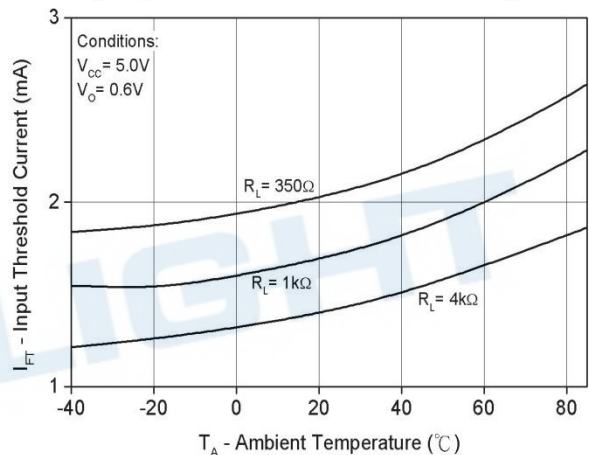

Fig.5 Output Voltage vs. Input Forward Current

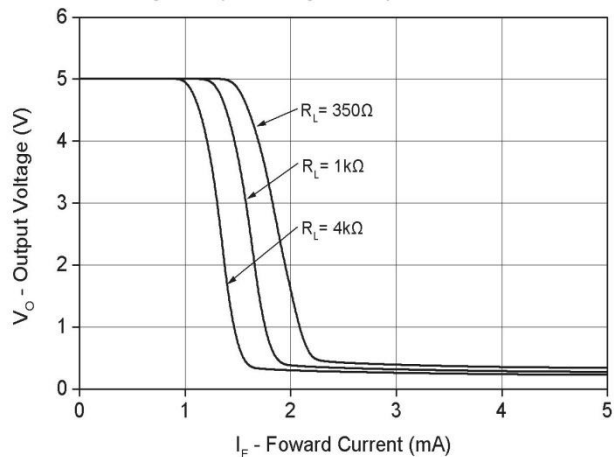

Fig.6 High Level Output Current vs. Temperature

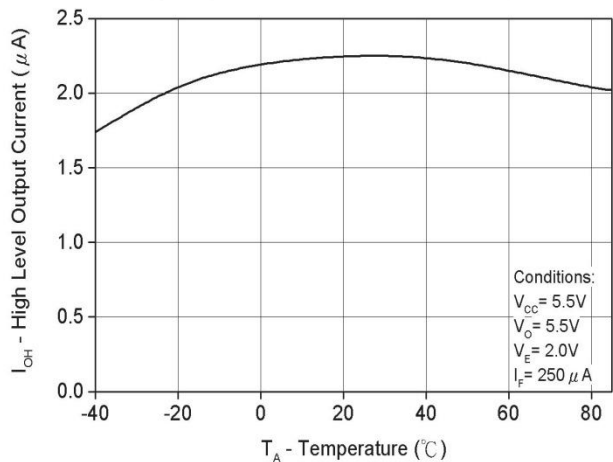

Fig.7 Switching Time vs. Forward Current

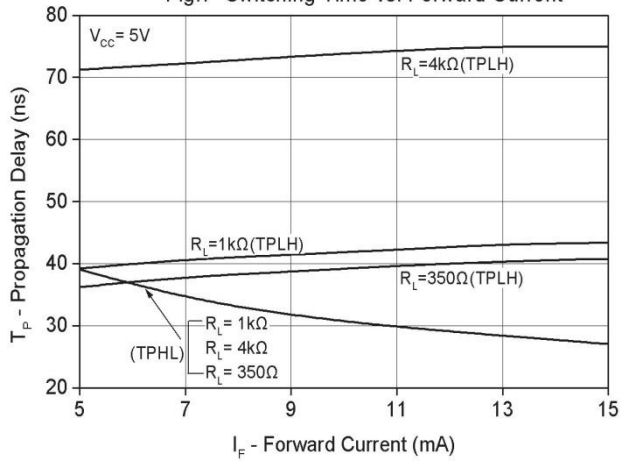

Fig.8 Switching Time vs. Temperature

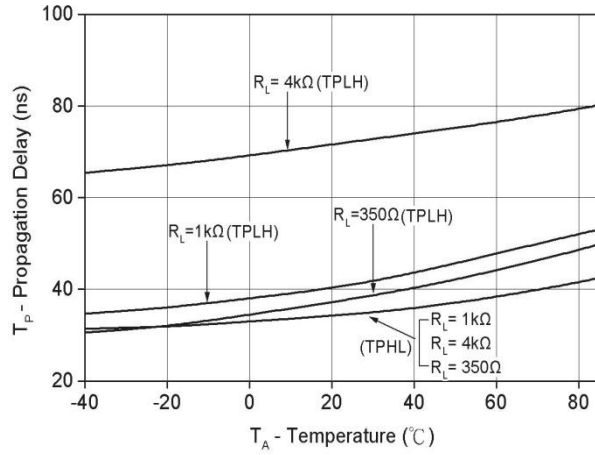

Fig.9 Pulse Width Distortion vs. Temperature

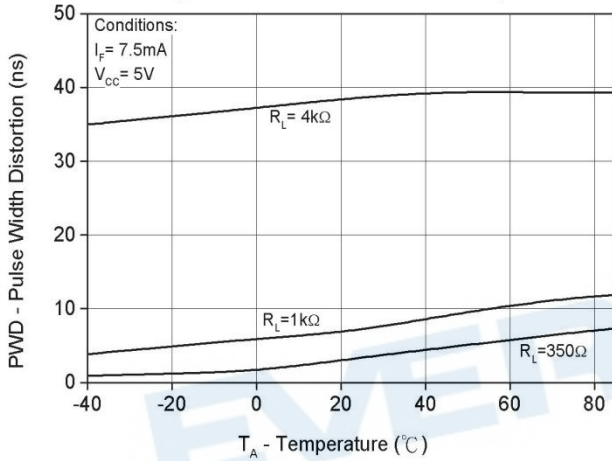

Fig.10 Rise and Fall Time vs. Temperature

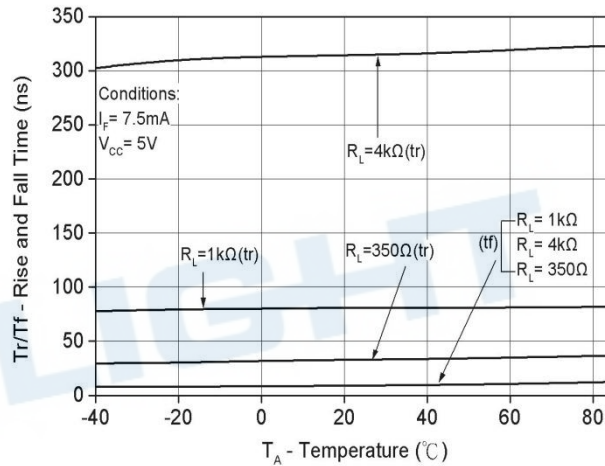

Fig.11 Enable Propagation Delay vs. Temperature

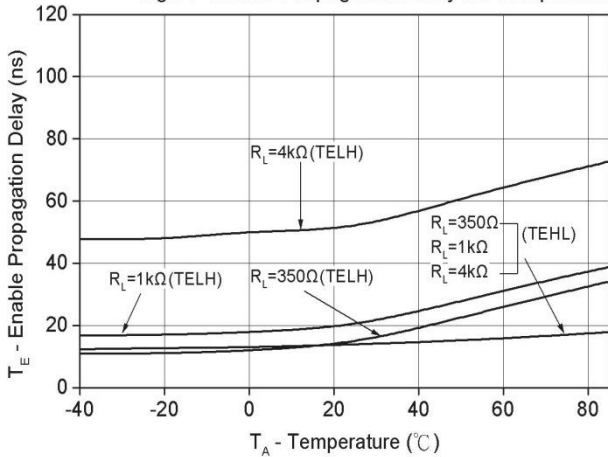

Fig. 12 Test circuit and waveforms for t_{PHL} , t_{PLH} , t_r , and t_f

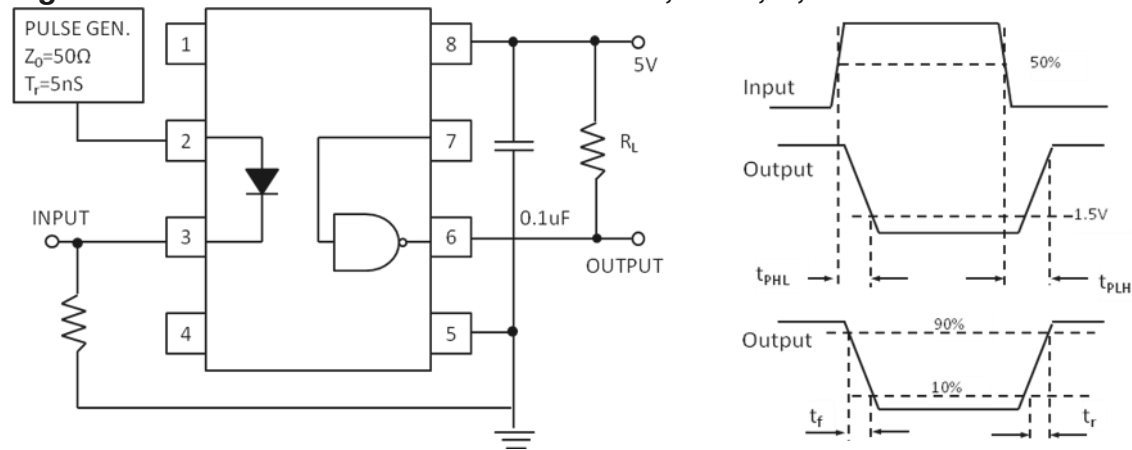

Fig. 13 Test circuit and waveform for t_{EHL} and t_{ELH}

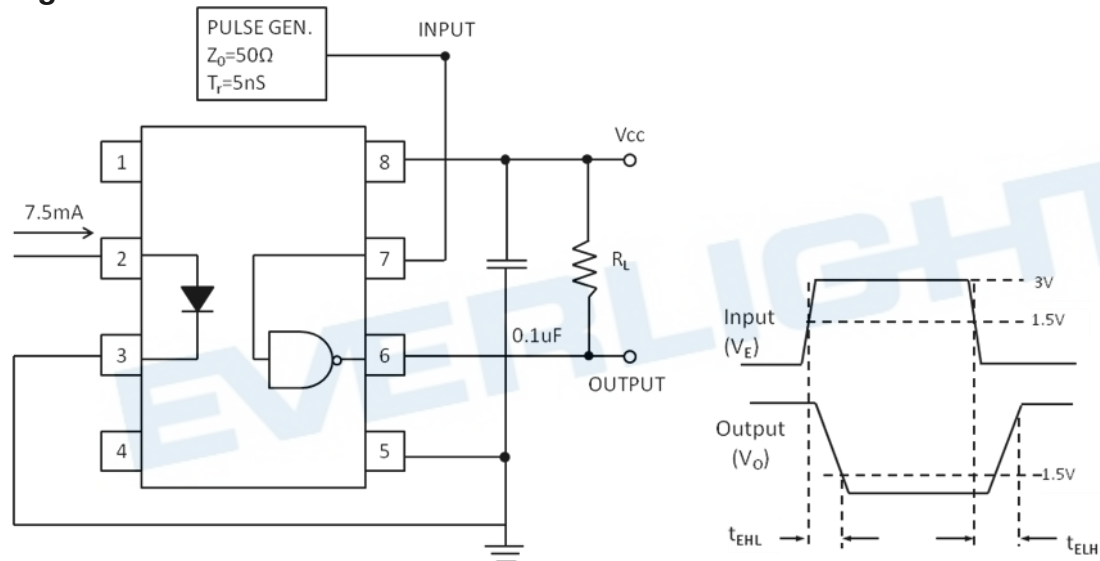

Fig. 14 Test circuit Common mode Transient Immunity

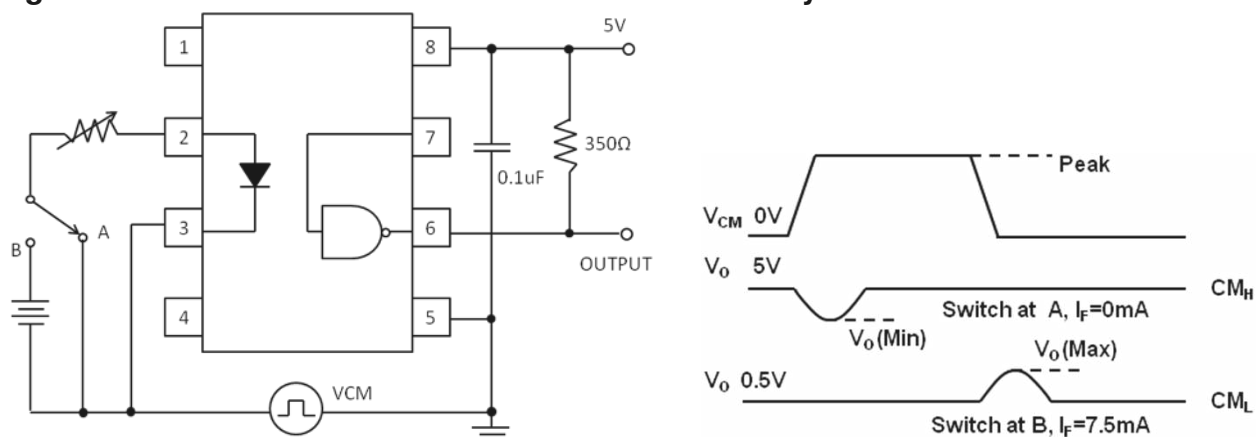
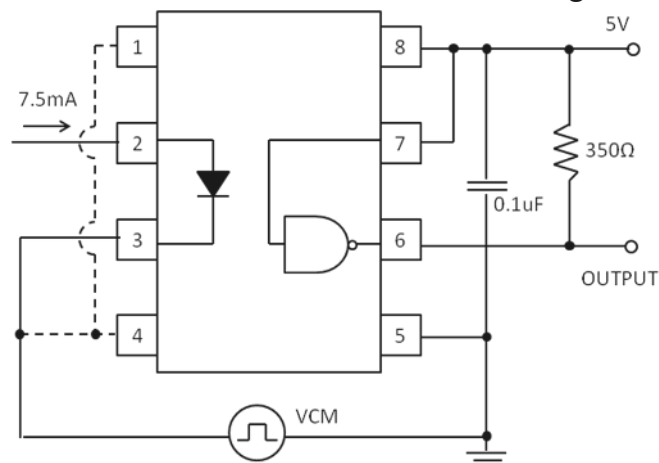

Fig. 15 Recommended drive circuit for EL2611 families for high-CMR**Note**

- *3 The VCC supply must be bypassed by a 0.1μF capacitor or larger. This can be either a ceramic or solid tantalum capacitor with good high frequency characteristic and should be connected as close as possible to the package VCC and GND pins
- *4. Enable Input – No pull up resistor required as the device has an internal pull up resistor.
- *5. tPLH – Propagation delay is measured from the 3.75mA level on the HIGH to LOW transition of the input current pulse to the 1.5 V level on the LOW to HIGH transition of the output voltage pulse.
- *6. tPHL – Propagation delay is measured from the 3.75mA level on the LOW to HIGH transition of the input current pulse to the 1.5 V level on the HIGH to LOW transition of the output voltage pulse.
- *7. tr – Rise time is measured from the 90% to the 10% levels on the LOW to HIGH transition of the output pulse.
- *8. tf – Fall time is measured from the 10% to the 90% levels on the HIGH to LOW transition of the output pulse.
- *9. tELH – Enable input propagation delay is measured from the 1.5V level on the HIGH to LOW transition of the input voltage pulse to the 1.5V level on the LOW to HIGH transition of the output voltage pulse.
- *10. tEHL – Enable input propagation delay is measured from the 1.5V level on the LOW to HIGH transition of the input voltage pulse to the 1.5V level on the HIGH to LOW transition of the output voltage pulse.
- *11 CMH– The maximum tolerable rate of rise of the common mode voltage to ensure the output will remain in the HIGH state (i.e., VOUT > 2.0V).
- *12 CML– The maximum tolerable rate of rise of the common mode voltage to ensure the output will remain in the LOW output state (i.e., VOUT < 0.8V).

Order Information**Part Number****6N137Y(Z)-V**

or

EL26XXY(Z)-V**Note**

- X = (01 or 11) for EL26 part no.
 Y = Lead form option (S, S1, M or none)
 Z = Tape and reel option (TA, TB or none).
 V = VDE (optional)

| Option | Description | Packing quantity |
|---------|---|---------------------|
| None | Standard DIP-8 | 45 units per tube |
| M | Wide lead bend (0.4 inch spacing) | 45 units per tube |
| S (TA) | Surface mount lead form + TA tape & reel option | 1000 units per reel |
| S (TB) | Surface mount lead form + TB tape & reel option | 1000 units per reel |
| S1 (TA) | Surface mount lead form (low profile) + TA tape & reel option | 1000 units per reel |
| S1 (TB) | Surface mount lead form (low profile) + TB tape & reel option | 1000 units per reel |

Package Dimension (Dimensions in mm)

Standard DIP Type

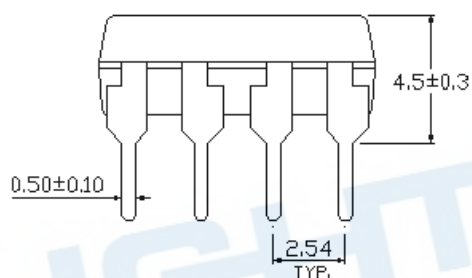
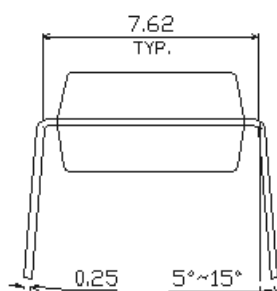
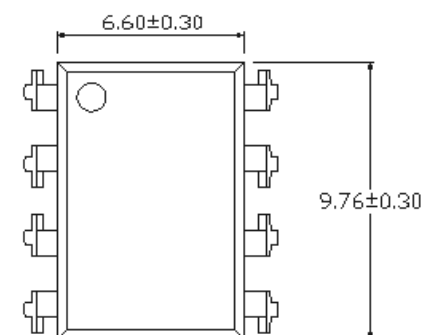

Option M Type

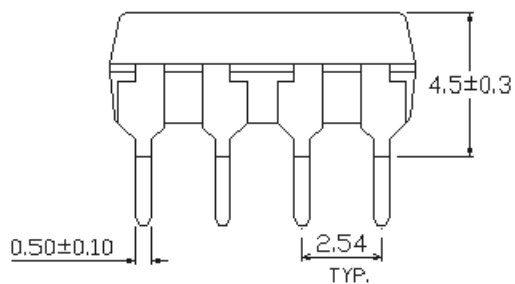
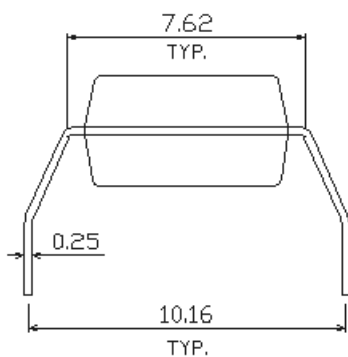
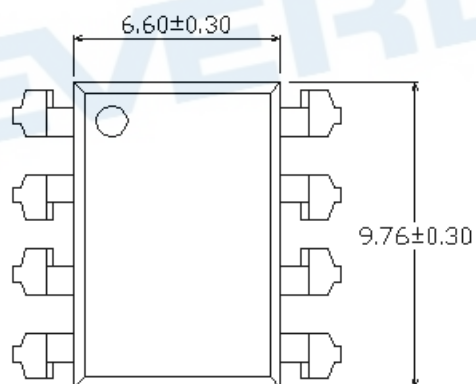

Option S Type

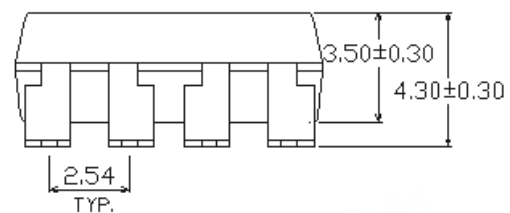
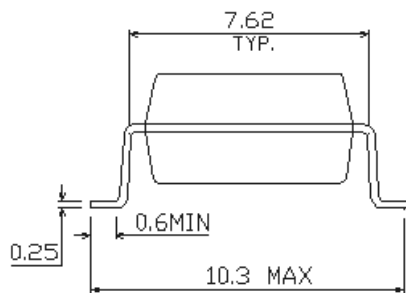
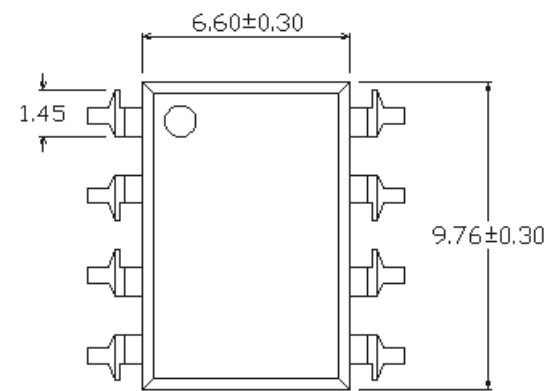

Option S1 Type

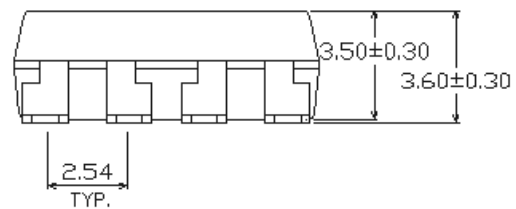
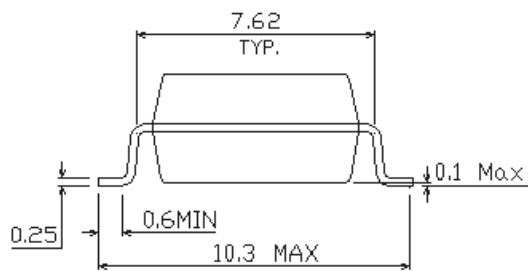
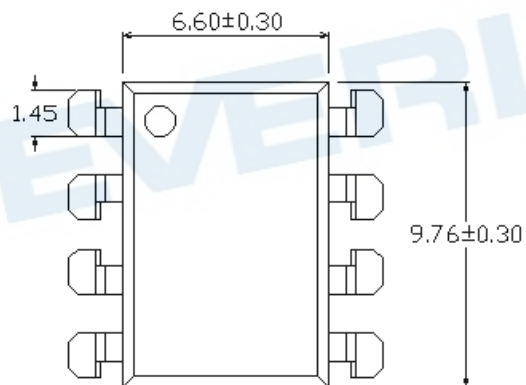

Recommended pad layout for surface mount leadform

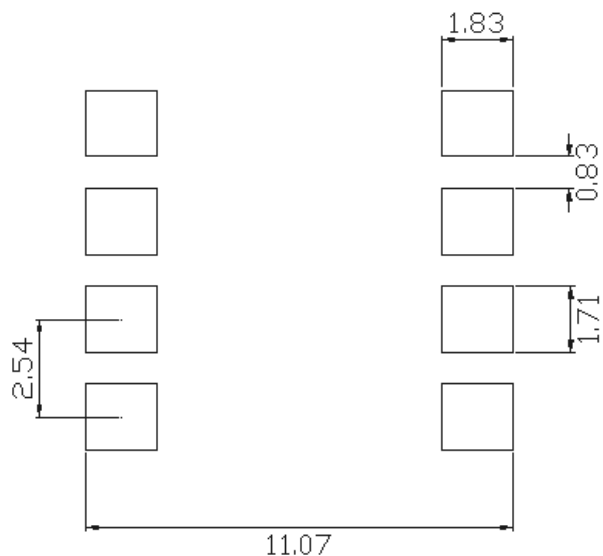

Notes.

Suggested pad dimension is just for reference only.

Please modify the pad dimension based on individual need.

Device Marking

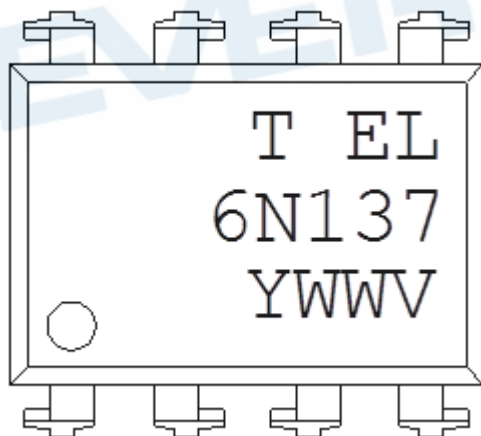

Notes

| | |
|-------|--|
| T | denotes Factory No code : made in China T : made in Taiwan |
| EL | denotes EVERLIGHT |
| 6N137 | denotes Device Number |
| Y | denotes 1 digit Year code |
| WW | denotes 2 digit Week code |
| V | denotes VDE (optional) |

Tape & Reel Packing Specifications

Option TA

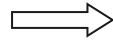
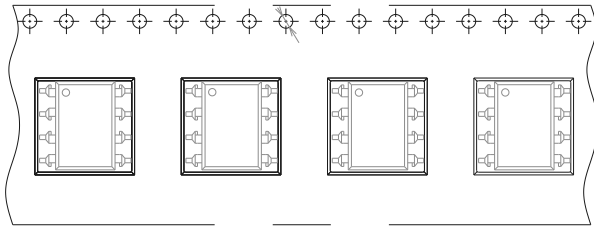

Direction of feed from reel

Option TB

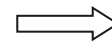
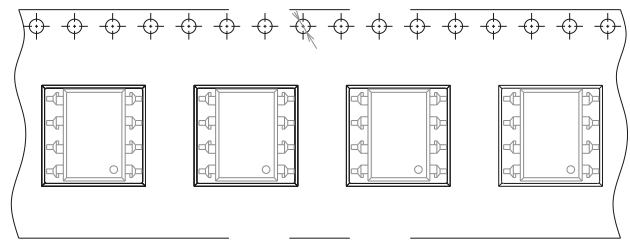

Direction of feed from reel

Tape dimension

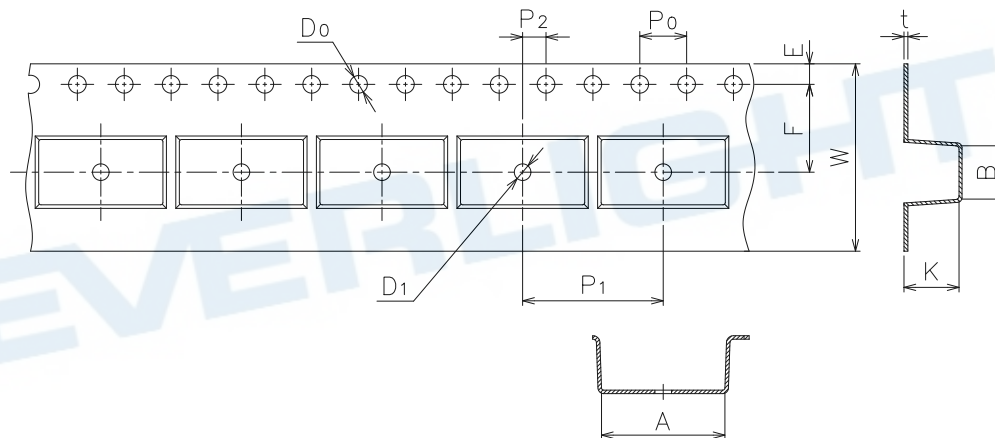

| | | | | | | |
|---------------|-----------|-----------|-----------|-----------|----------|----------|
| Dimension No. | A | B | Do | D1 | E | F |
| Dimension(mm) | 10.4±0.1 | 10.0±0.1 | 1.5+0.1-0 | 1.5±0.25 | 1.75±0.1 | 7.5±0.1 |
| Dimension No. | Po | P1 | P2 | t | W | K |
| Dimension(mm) | 4.0±0.1 | 12.0±0.1 | 2.0±0.05 | 0.4±0.05 | 16.0±0.3 | 4.5±0.1 |

Precautions for Use

1. Soldering Condition

1.1 (A) Maximum Body Case Temperature Profile for evaluation of Reflow Profile

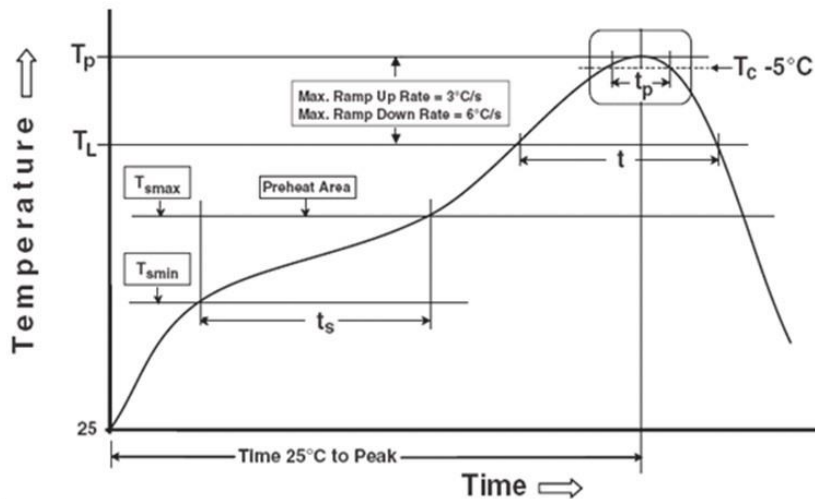

Note:

Reference: IPC/JEDEC J-STD-020D

Preheat

| | |
|--|-----------------|
| Temperature min (T_{smin}) | 150 °C |
| Temperature max (T_{smax}) | 200°C |
| Time (T_{smin} to T_{smax}) (t_s) | 60-120 seconds |
| Average ramp-up rate (T_{smax} to T_p) | 3 °C/second max |

Other

| | |
|--|------------------|
| Liquidus Temperature (T_L) | 217 °C |
| Time above Liquidus Temperature (t_L) | 60-100 sec |
| Peak Temperature (T_p) | 260°C |
| Time within 5 °C of Actual Peak Temperature: $T_p - 5^\circ C$ | 30 s |
| Ramp- Down Rate from Peak Temperature | 6°C /second max. |
| Time 25°C to peak temperature | 8 minutes max. |
| Reflow times | 3 times |

DISCLAIMER

1. Above specification may be changed without notice. EVERLIGHT will reserve authority on material change for above specification.
2. The graphs shown in this datasheet are representing typical data only and do not show guaranteed values.
3. When using this product, please observe the absolute maximum ratings and the instructions for use outlined in these specification sheets. EVERLIGHT assumes no responsibility for any damage resulting from use of the product which does not comply with the absolute maximum ratings and the instructions included in these specification sheets.
4. These specification sheets include materials protected under copyright of EVERLIGHT. Reproduction in any form is prohibited without the specific consent of EVERLIGHT.
5. This product is not intended to be used for military, aircraft, automotive, medical, life sustaining or life saving applications or any other application which can result in human injury or death. Please contact authorized Everlight sales agent for special application request.
6. Statements regarding the suitability of products for certain types of applications are based on Everlight's knowledge of typical requirements that are often placed on Everlight products in generic applications. Such statements are not binding statements about the suitability of products for a particular application. It is the customer's responsibility to validate that a particular product with the properties described in the product specification is suitable for use in a particular application. Parameters provided in datasheets and/or specifications may vary in different applications and performance may vary over time. All operating parameters, including typical parameters, must be validated for each customer application by the customer's technical experts. Product specifications do not expand or otherwise modify Everlight's terms and conditions of purchase, including but not limited to the warranty expressed therein.