



Infrared Product Data Sheet HSDL-4251

Spec No. :DS50-2008-0024
Effective Date: 05/25/2023
Revision: C

LITE-ON DCC

RELEASE

BNS-OD-FC001/A4

IR Emitter HSDL-4251

1. Description

Lite-On offers a broad range of discrete infrared components for application such as remote controller, IR wireless data transmission, security alarm & etc. The product line includes GaAs 940nm IREDs, AlGaAs high power 880nm IREDs, AlGaAs high speed 875nm/850nm IREDs, PIN Photodiodes, Phototransistor and Photodarlington.

1.1. Features

- Lead (Pb) free product and RoHS compliant.
- High speed: 40ns rise times
- High power AlGaAs LED technology
- Clear transparent color package
- 870nm IR emitter

1.2. Applications

- Industrial Infrared Equipments and application
- Portable Infrared Instruments
- Consumer Electronics
(Optical mouse, Infrared Remote Controllers ect)
- High Speed Infrared Communications
(IR LANs , IR Moldens , IR Dongles , etc)

2. Outline Dimensions

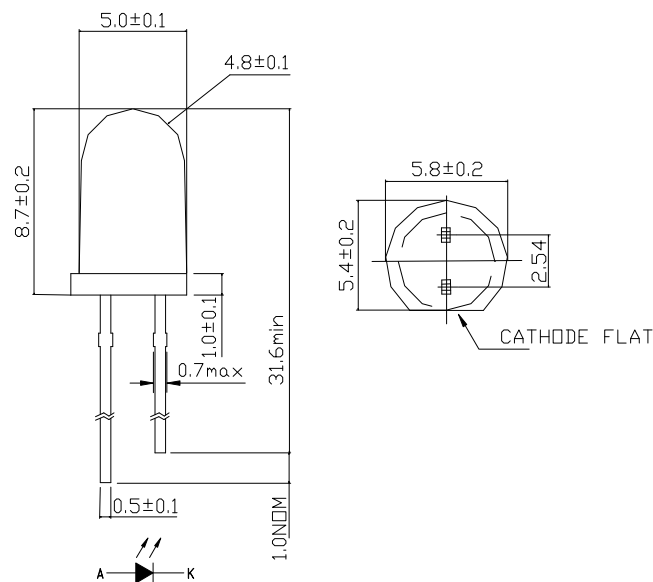

Notes :

1. All dimensions are in millimeters (inches).
2. Tolerance is ± 0.25 mm (.010") unless otherwise noted.
3. Protruded resin under flange is 1.5 mm (.059") max.
4. Lead spacing is measured where the leads emerge from the package.
5. Specifications are subject to change without notice.

IR Emitter HSDL-4251

3. Absolute Maximum Ratings at TA=25°C

Parameter	Symbol	MIN	Max	Unit	Reference
Forward Current	I _{FDC}		100	mA	[1]
Peak Forward Current	I _{FPK}		500	mA	Fig 3 Duty Factor=20%, Pulse Width=100us
Power Dissipation	P _{DISS}		190	mW	
Reverse Voltage	V _R	5		V	I _R =100uA
Storage Temperature Range	T _S	-40	100	°C	
LED Junction Temperature	T _J		110	°C	
Lead Soldering Temperature [1.6mm (.063") From Body]			260°C for 5 Seconds		
Operating Temperature	T _O	-40	85	°C	

Notes:

1. Derate as shown in Figure 6.

IR Emitter HSDL-4251

4. Electrical / Optical Characteristics at TA=25°C

Parameter	Symbol	Min.	Typ.	Max.	Unit	Test Condition
Radiant On-Axis Intensity	IE	56	100	168	mW/sr	IF = 100mA
Peak Emission Wavelength	λ_{Peak}	-	870	-	nm	IF = 50mA
Spectral Line Half-Width	$\Delta\lambda$	-	45	-	nm	IF = 20mA
Forward Voltage	Vf	-	1.4	1.6	V	IF = 20mA
Forward Voltage	Vf	-	1.5	1.9	V	IF = 100mA
Forward Voltage Temperature Coefficient	$\Delta V/\Delta T$	-	-1.44	-	mV/°C	IF = 100mA
Viewing Angle (See Fig.6)	$2\theta_{1/2}$	-	30	-	deg.	
Radiant On-Axis Intensity Temperature Coefficient	$\Delta IE/\Delta T$	-	-0.43	-	%/°C	IF = 100mA
Peak Wavelength Temperature Coefficient	$\Delta \lambda/\Delta T$	-	0.22	-	nm/°C	IF = 100mA
Optical Rise and all Times, 10%-90%	Tr/ Tf	-	40	-	ns	IFDC = 500 mA Duty Ratio=20% Pulse Width=125ns
Series Resistance	RS	-	2.5	-	Ohms	IF = 100mA
Diode Capacitance	CO	-	75	-	pF	0 V,1 MHz
Thermal Resistance, Junction to Pin	R θ_{JA}	-	300	-	°C/W	

**IR Emitter
HSDL-4251**

5. Typical Electrical / Optical Characteristics Curves

(25°C Ambient Temperature Unless Otherwise Noted)

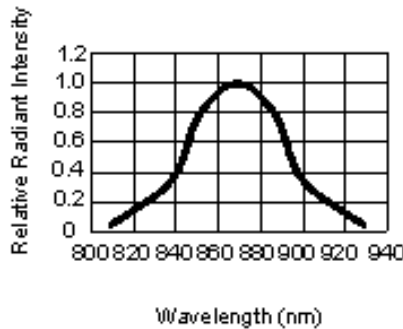

FIG.1 Relative Radiant Intensity VS Wavelength

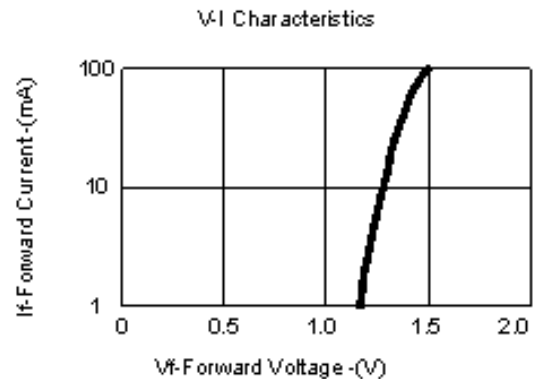

FIG.2 DC Forward Current VS. Forward Voltage

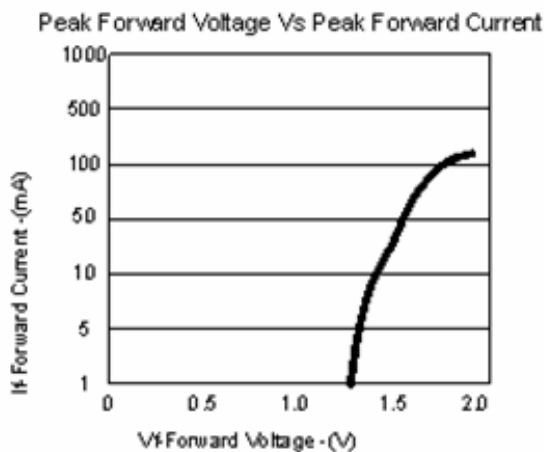

FIG.3 Peak Forward Current VS. Forward Voltage

Forward Current Vs Relative Radiant Intensity

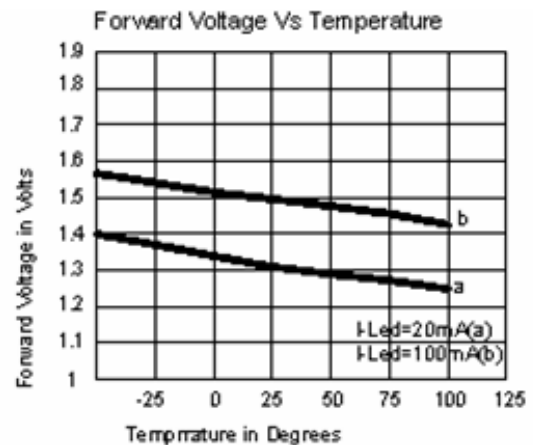

FIG.4 Forward Voltage VS. Ambient Temperature

Forward Current Vs Relative Radiant Intensity

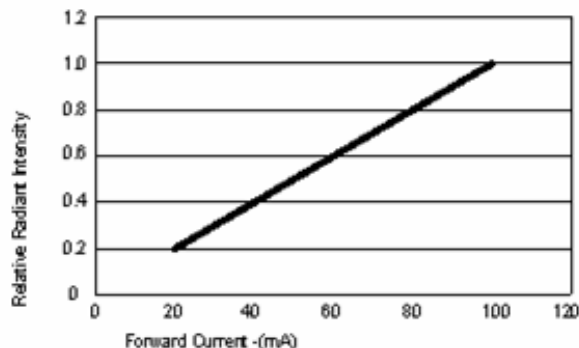

FIG.5 Relative Radiant Intensity vs DC Forward Current

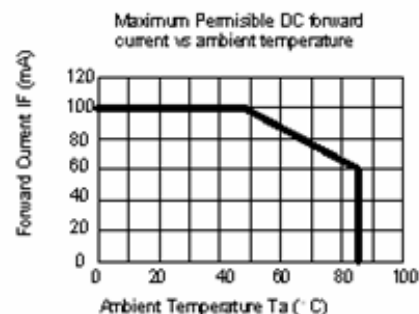

FIG.6 DC FORWARD CURRENT VS. AMBIENT TEMPERATURE DERATED (Based on TJMAX=110°C)

IR Emitter HSDL-4251

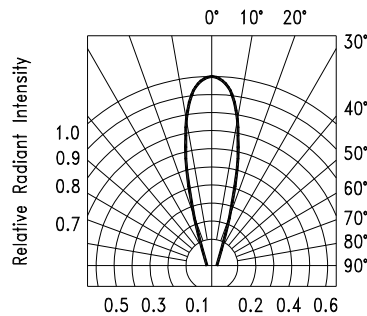

FIG.7 RADIATION DIAGRAM

6. CAUTIONS

6.1. Application

The LEDs described here are intended to be used for ordinary electronic equipment. Consult Liteon's Sales in advance for information on applications in which exceptional reliability is required, particularly when the failure or malfunction of the LEDs may directly jeopardize life or health (such as in aviation, traffic control equipment, medical & life support systems and safety devices).

6.2. Storage

The storage ambient for the LEDs should not exceed 30°C temperature or 70% relative humidity. It is recommended that LEDs out of their original packaging are used within three months. For extended storage out of their original packaging, it is recommended that the LEDs be stored in a sealed container with appropriate desiccant or in desiccators with nitrogen ambient.

6.3. Cleaning

Use alcohol-based cleaning solvents such as isopropyl alcohol to clean the LEDs if necessary.

6.4. Lead Forming & Assembly

During lead forming, the leads should be bent at a point at least 3mm from the base of LED lens. Do not use the base of the lead frame as a fulcrum during forming. Lead forming must be done before soldering, at normal temperature. During assembly on PCB, use minimum clinch force possible to avoid excessive mechanical stress.

6.5. Soldering

Dipping the lens into the solder must be avoided. Do not apply any external stress to the lead frame during soldering while the LED is at high temperature.

Recommended soldering conditions:

Soldering iron		Wave soldering	
Temperature	350°C Max.	Pre-heat	100°C Max.
Soldering time	5 seconds Max. (one time only)	Pre-heat time	60 seconds Max.
Position	No closer than 1.6mm from the base of the epoxy bulb	Solder wave	260°C Max.
		Soldering time	5 seconds Max.
		Dipping Position	No lower than 1.6mm from the base of the epoxy bulb

Note: Excessive soldering temperature and/or time might result in deformation of the LED lens or catastrophic failure of the LED. IR reflow is not suitable process for through hole type LED lamp product.

IR Emitter HSDL-4251

6.6. Drive Method

LED is a current-operated device. In order to ensure intensity uniformity on multiple LEDs connected in parallel in an application, it is recommended that a current limiting resistor be incorporated in the drive circuit, in series with each LED as shown in Circuit A below.



(A) Recommended circuit

(B) The brightness of each LED might appear different due to the differences in the I-V characteristics of those LEDs.

6.7. ESD (Electrostatic Discharge)

Static Electricity or power surge will damage the LED.

Suggestions to prevent ESD damage:

- Use a conductive wrist band or anti- electrostatic glove when handling these LEDs
- All devices, equipment, and machinery must be properly grounded
- Work tables, storage racks, etc. should be properly grounded
- Use ion blower to neutralize the static charge which might have built up on surface of the LEDs plastic lens as a result of friction between LEDs during storage and handing

Suggested checking list:

Training and Certification

6.7.1.1. Everyone working in a static-safe area is ESD-certified?

6.7.1.2. Training records kept and re-certification dates monitored?

Static-Safe Workstation & Work Areas

6.7.2.1. Static-safe workstation or work-areas have ESD signs?

6.7.2.2. All surfaces and objects at all static-safe workstation and within 1 ft measure less than 100V?

6.7.2.3. All ionizer activated, positioned towards the units?

6.7.2.4. Each work surface mats grounding is good?

Personnel Grounding

6.7.3.1. Every person (including visitors) handling ESD sensitive (ESDS) items wear wrist strap, heel strap or conductive shoes with conductive flooring?

6.7.3.1. If conductive footwear used, conductive flooring also present where operator stand or walk?

6.7.3.2. Garments, hairs or anything closer than 1 ft to ESD items measure less than 100V*?

6.7.3.3. Every wrist strap or heel strap/conductive shoes checked daily and result recorded for all DLs?

6.7.3.4. All wrist strap or heel strap checkers calibration up to date?

Device Handling

6.7.4.1. Every ESDS items identified by EIA-471 labels on item or packaging?

6.7.4.2. All ESDS items completely inside properly closed static-shielding containers when not at static-safe workstation?

6.7.4.3. No static charge generators (e.g. plastics) inside shielding containers with ESDS items?

6.7.4.4. All flexible conductive and dissipative package materials inspected before reuse or recycle?

Others

6.7.5.1. Audit result reported to entity ESD control coordinator?

6.7.5.2. Corrective action from previous audits completed?

6.7.5.3. Are audit records complete and on file?

IR Emitter HSDL-4251

7. Reliability Test

Classification	Test Item	Test Condition	Reference Standard
Endurance Test	High Temperature High Humidity Reverse Bias	Ta= 65°C RH= 95% VR=5V Test Time= 500HRS	MIL-STD-750D:1026 (1995) MIL-STD-883G:1005 (2006)
	High Temperature High Humidity storage	Ta= 65°C RH= 95% Test Time= 240HRS	MIL-STD-202G:103B (2002) JEITA ED-4701:100 103 (2001)
	High Temperature Storage	Ta= 105±5°C Test Time= 1000HRS	MIL-STD-750D:1031 (1995) MIL-STD-883G:1008 (2006) JEITA ED-4701:200 201 (2001)
	Low Temperature Storage	Ta= -55±5°C Test Time=1000HRS	JEITA ED-4701:200 202 (2001)
Environmental Test	Temperature Cycling	-55°C ~ 25°C ~ 105°C ~ 25°C 30mins 5mins 30mins 5mins Test time: 30 Cycles	MIL-STD-750D:1051 (1995) MIL-STD-883G:1010 (2006) JEITA ED-4701:100 105 (2001) JESD22-A104C (2005)
	Thermal Shock	105 ± 5°C ~ -55°C ± 5°C 10mins 10mins Test time: 20 Cycles	MIL-STD-750D:1056 (1995) MIL-STD-883G:1011 (2006) MIL-STD-202G:107G (2002) JESD22-A106B (2004)
	Solder Resistance	T.sol = 260 ± 5°C Dwell Time= 10±1 seconds 3mm from the base of the epoxy bulb	MIL-STD-750D:2031(1995) JEITA ED-4701: 300 302 (2001)
	Solder Ability	T. sol = 245 ± 5°C Dwell Time= 5 ± 0.5 seconds (Lead Free Solder, Coverage ≥ 95% of the dipped surface)	MIL-STD-750D:2026 (1995) MIL-STD-883G:2003 (2006) MIL-STD-202G:208H (2002) IPC/EIA J-STD-002 (2004)

8. Others

The appearance and specifications of the product may be modified for improvement, without prior notice.