

### IRR60-48C/TR8

#### Features

- Compatible with infrared and vapor phase reflow solder process.
- Compatible with automatic placement equipment.
- Bi-color LED wavelength. (660nm, 905nm)
- Compliance Halogen Free(Br < 900ppm, Cl < 900ppm, Br+Cl < 1500ppm)
- Compliance with EU REACH
- This product itself will remain within RoHS compliant version.
- Package size : 6.0mm\*4.8mm\*1.1mm

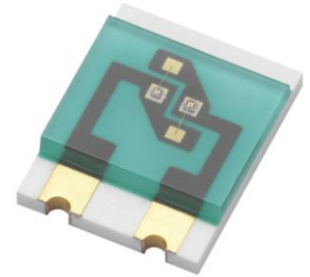

#### Description

- **IRR60-48C/TR8** is an infrared emitting diode in miniature SMD package, which is molded in a water clear plastic with flat top view lens. The device is spectrally matched with silicon photodiode and phototransistor.

#### Applications

- Sensor
- Oximeter

#### Device Selection Guide

Device No.	Chip Material	Lens Color
IRR60-48C/TR8	AlGaInP (660nm) AlGaAs (905nm)	Water clear

## Package Dimensions

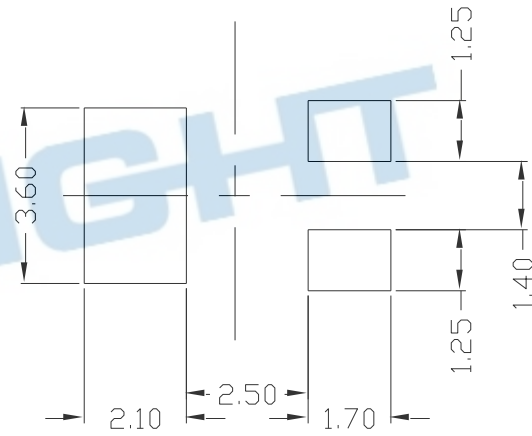
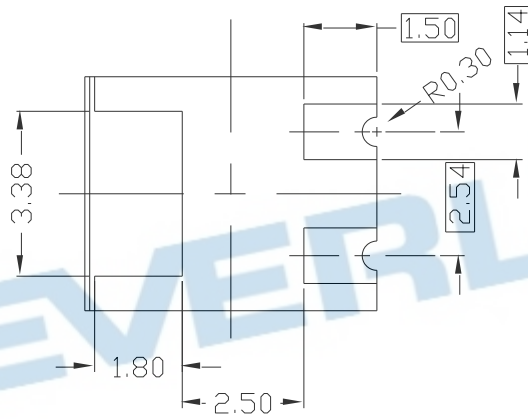
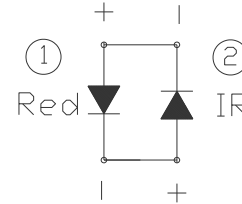
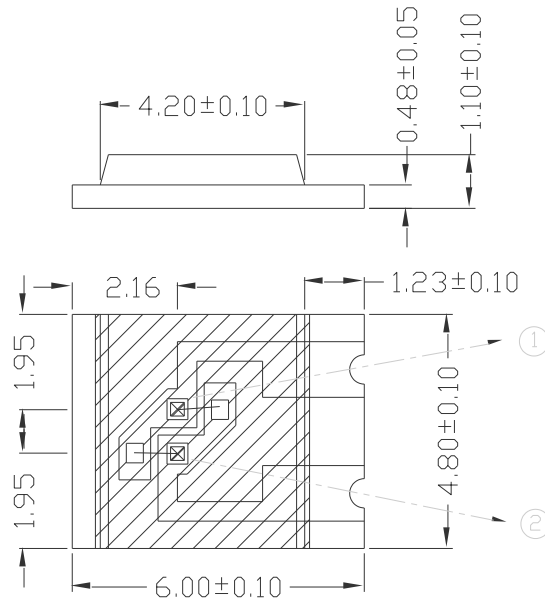

### ● Notes:

1. All dimensions are in millimeters
2. Tolerances unless dimensions  $\pm 0.1\text{mm}$

## Absolute Maximum Ratings (Ta=25°C)

Parameter	Symbol	Ratings		Unit
		660nm(Red)	910nm(IR)	
Continuous Forward Current	I <sub>F</sub>	30		mA
Peak Forward Current *1	I <sub>FP</sub>	150		mA
Reverse Voltage	V <sub>R</sub>	5		V
Operating Temperature	T <sub>opr</sub>	-25~ +85		°C
Storage Temperature	T <sub>stg</sub>	-25 ~ +85		°C
Soldering Temperature *2	T <sub>sol</sub>	260		°C
Power Dissipation at(or below) 25°C Free Air Temperature	P <sub>d</sub>	70	50	mW
Temperature resistance junction ambient	R <sub>thj-a</sub>	550		K/W

**Notes:** \*1:I<sub>FP</sub> Conditions--Pulse Width ≤ 10μ s and Duty ≤ 1%.

\*2:Soldering time ≤ 5 seconds.

## Electro-Optical Characteristics (Ta=25°C)

Parameter	Symbol		Condition	Min.	Typ.	Max.	Unit
<b>Radiant Intensity</b>	I <sub>E</sub>	Red	I <sub>F</sub> =20mA	1.0	2.3	--	mW /sr
		IR		0.5	1.0	--	
<b>Total Radiated Power</b>	P <sub>O</sub>	Red	I <sub>F</sub> =20mA	--	7.0	--	mW
		IR		--	3.0	--	
<b>Peak Wavelength</b>	λ <sub>p</sub>	Red	I <sub>F</sub> =20mA	657	660	663	nm
		IR		895	905	915	
<b>Spectral Bandwidth</b>	Δλ	Red	I <sub>F</sub> =20mA	--	20	--	nm
		IR		--	60	--	
<b>Forward Voltage</b>	V <sub>F</sub>	Red	I <sub>F</sub> =20mA	1.80	2.10	2.50	V
		IR		1.10	1.40	1.60	
<b>Reverse Current</b>	I <sub>R</sub>	Red	V <sub>R</sub> =5V	--	--	10	μ A
		IR		--	--	10	
<b>View Angle</b>	2θ 1/2	Red	I <sub>F</sub> =20mA	--	140	--	deg
		IR		--	130	--	

# Typical Electro-Optical Characteristics Curves

## Forward Current vs. Ambient Temperature (Red)

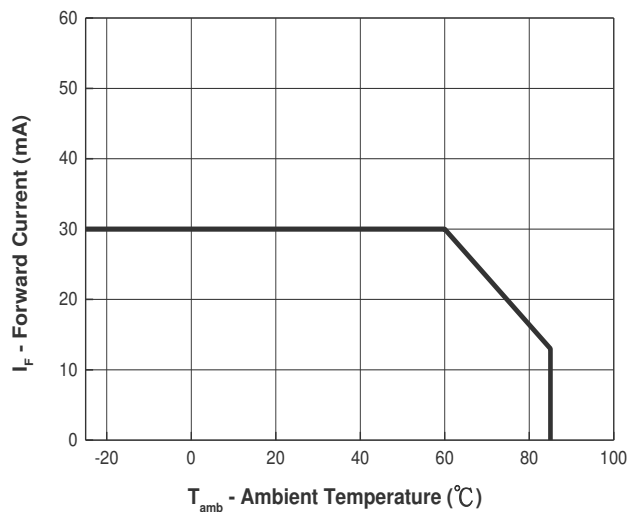

## Forward Current vs. Ambient Temperature (IR)

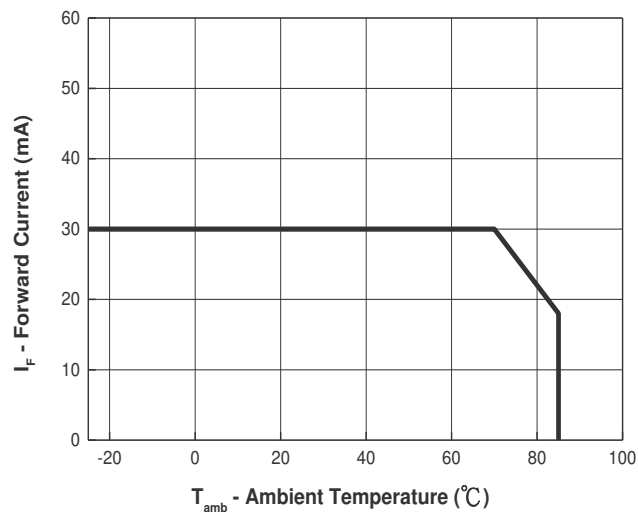

## Spectral Distribution (Red)

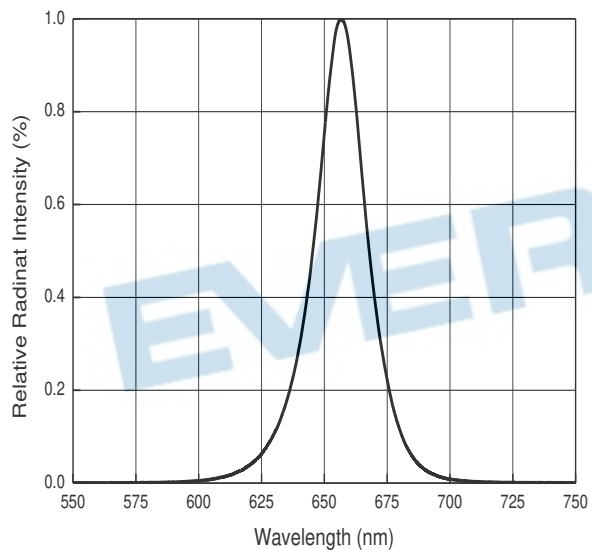

## Spectral Distribution (IR)

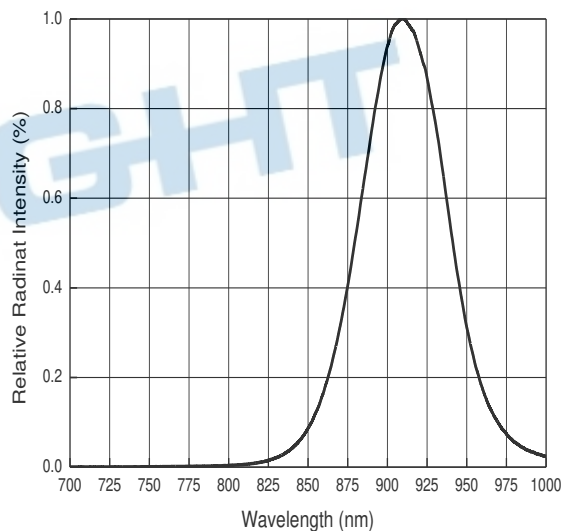

Radiant Intensity vs. Forward Current (Red)

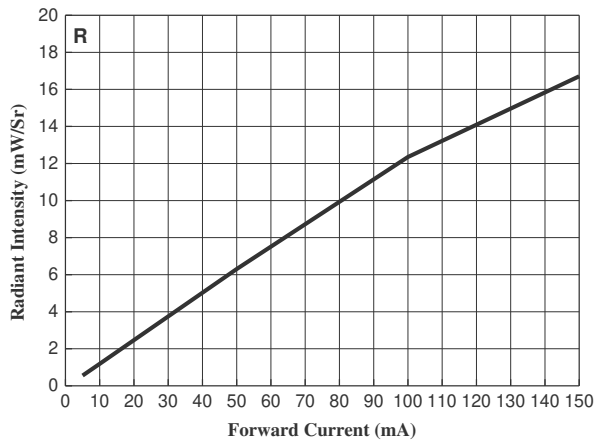

Radiant Intensity vs. Forward Current (IR)

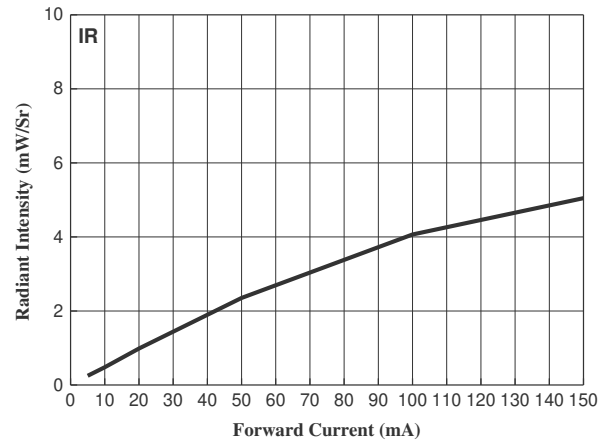

Forward Current vs. Forward Voltage (Red)

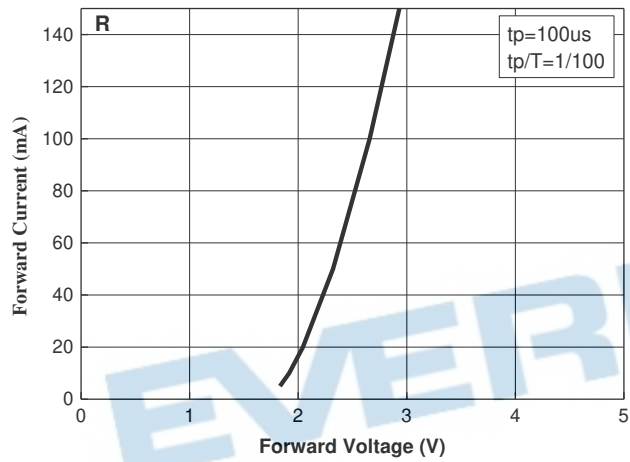

Forward Current vs. Forward Voltage (IR)

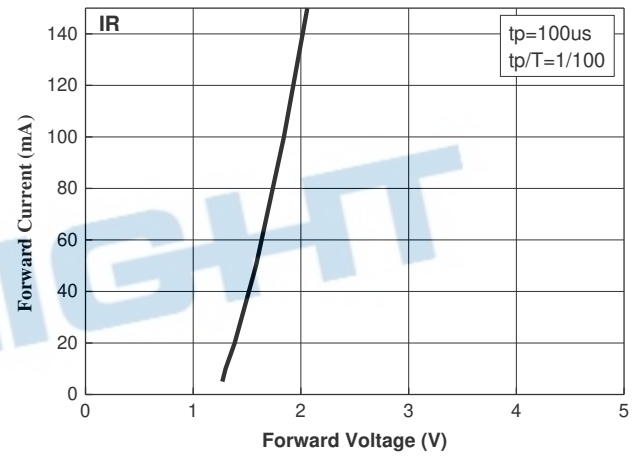

# Typical Electro-Optical Characteristics Curves

## Relative Radiant Intensity vs. Angular Displacement (Red)

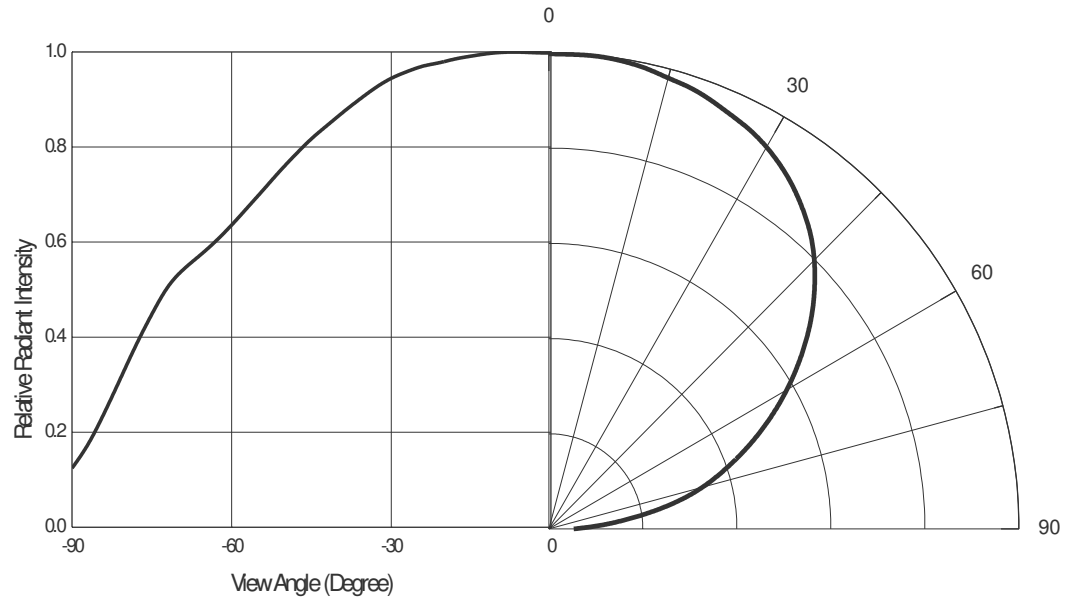

## Relative Radiant Intensity vs. Angular Displacement (IR)

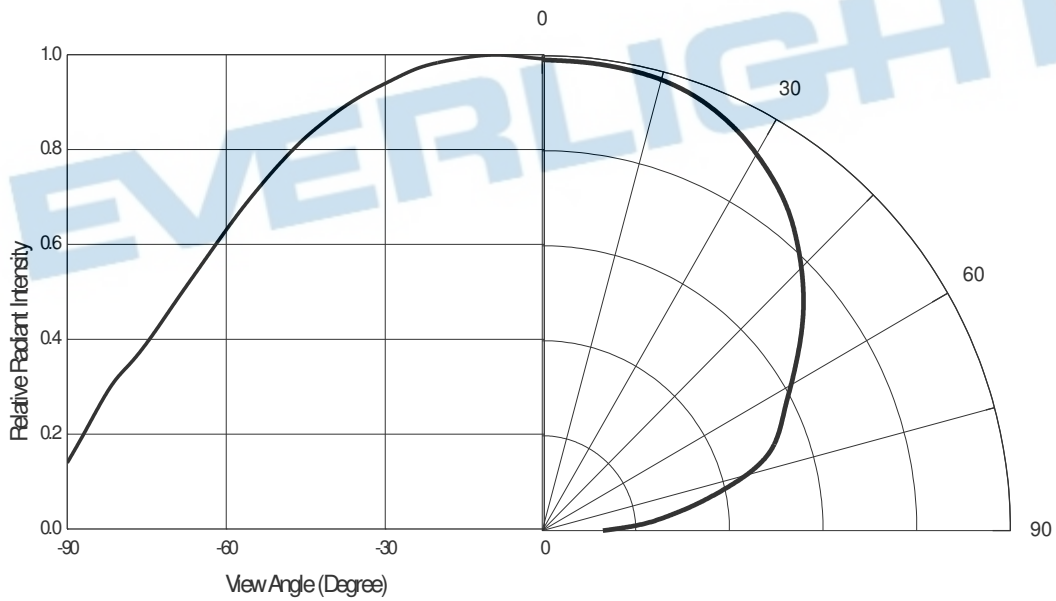

## Precautions For Use

### 1. Over-current-proof

Customer must apply resistors for protection , otherwise slight voltage shift will cause big current change ( Burn out will happen ).

### 2. Storage

2.1 Do not open moisture proof bag before the products are ready to use.

2.2 Before opening the package, the LEDs should be kept at 30°C or less and 90%RH or less.

2.3 The LEDs should be used within a year.

2.4 After opening the package, the LEDs should be kept at 30°C or less and 60%RH or less.

2.5 The LEDs should be used within 24 hours (1 days) after opening the package

2.6 If the moisture absorbent material (silica gel) has faded away or the LEDs have exceeded the storage time, baking treatment should be performed using the following conditions.

Baking treatment : 60±5°C for Min. Min. 24 hours.

### 3. Soldering Condition

#### 3.1 Pb-free solder temperature profile

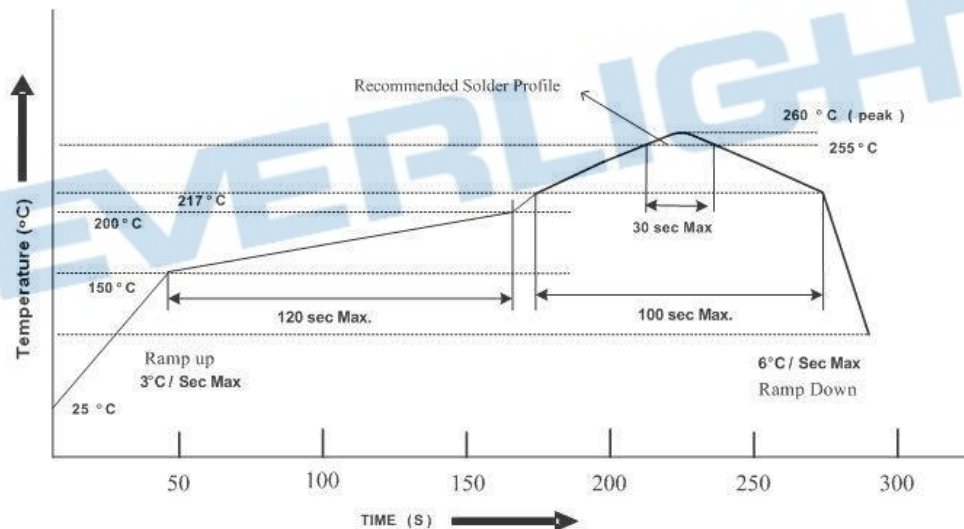

3.2 Reflow soldering should not be done more than two times.

3.3 When soldering, do not put stress on the LEDs during heating.

3.4 After soldering, do not warp the circuit board.

### 4. Soldering Iron

Each terminal is to go to the tip of soldering iron temperature less than 350°C for 3 seconds within once in less than the soldering iron capacity 25W. Leave two seconds and more intervals, and do soldering of each terminal. Be careful because the damage of the product is often started at the time of the hand solder.

### 5. Repairing

Repair should not be done after the LEDs have been soldered. When repairing is unavoidable, a

double-head soldering iron should be used (as below figure). It should be confirmed beforehand whether the characteristics of the LEDs will or will not be damaged by repairing.

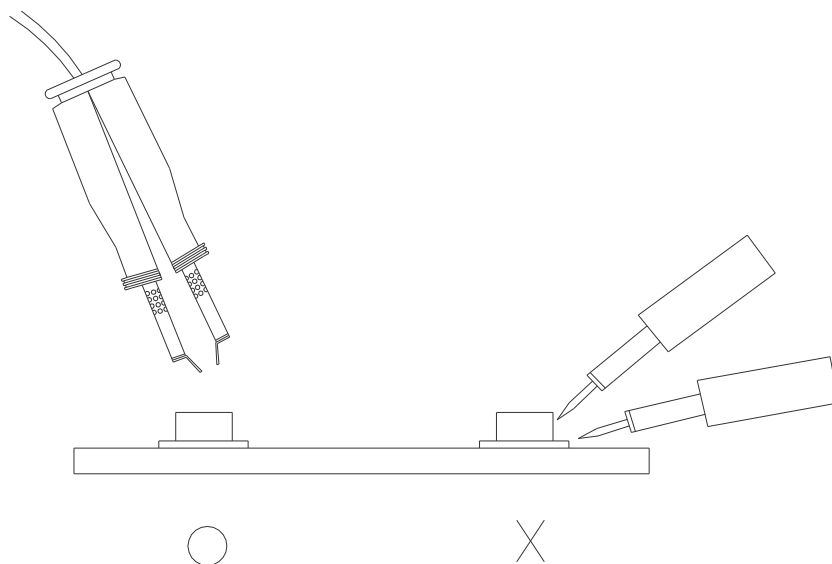

### Package Dimensions

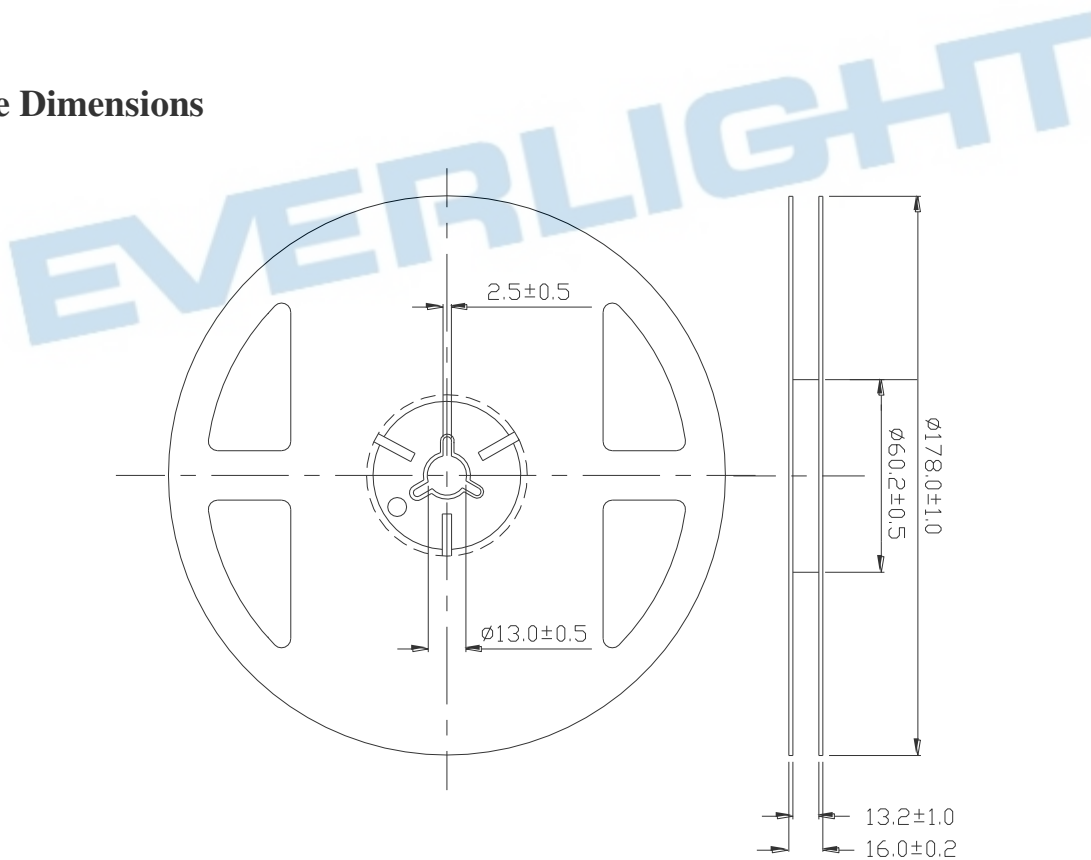

**Carrier Tape Dimensions: Loaded quantity 1000PCS per reel.**

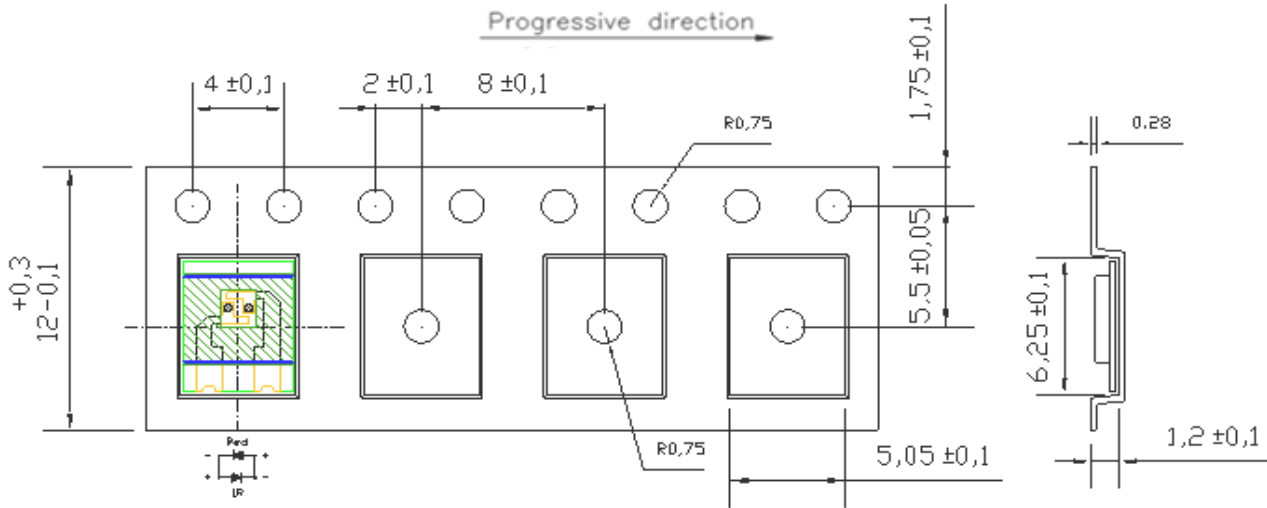

- Note:**
1. Dimensions are in millimeters
  2. The tolerances unless mentioned is  $\pm 0.1$ mm

**Moisture Resistant Packaging**

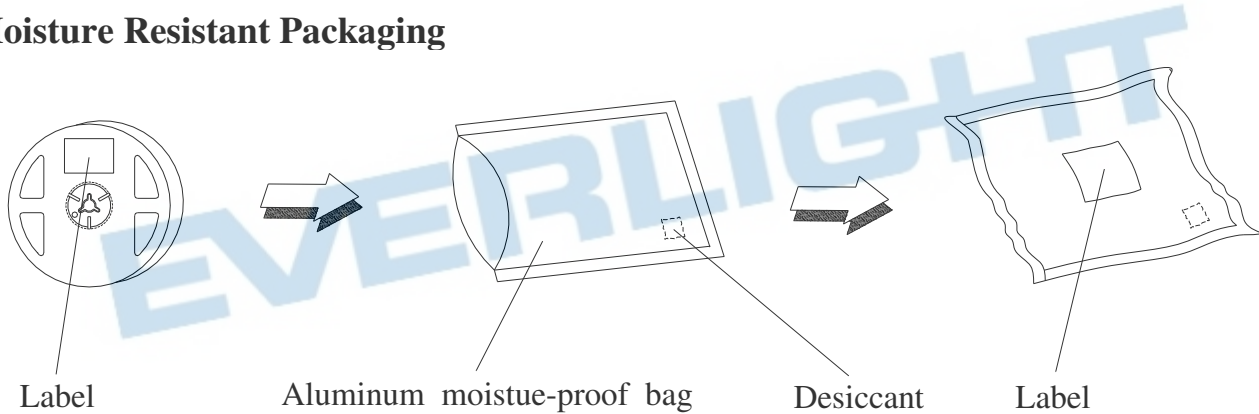

**Label Form Specification**

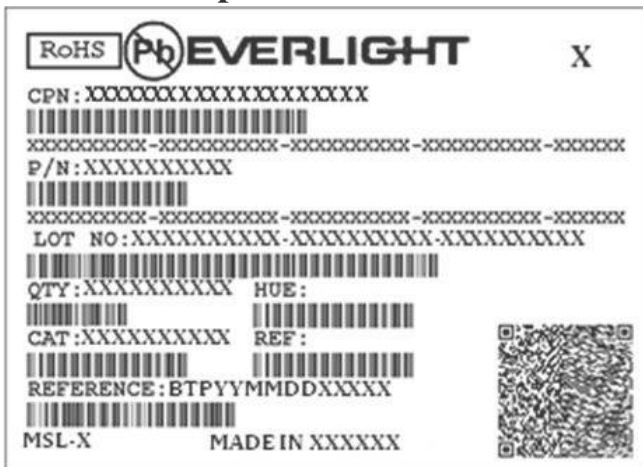

- CPN: Customer's Production Number
- P/N : Production Number
- QTY: Packing Quantity
- CAT: Ranks
- HUE: Peak Wavelength
- REF: Reference
- LOT No: Lot Number
- MADE IN TAIWAN: Production Place

## DISCLAIMER

1. EVERLIGHT AMERICAS reserves the right(s) on the adjustment of product material mix for the specification.
2. The product meets EVERLIGHT AMERICAS published specification for a period of twelve (12) months from date of shipment.
3. The graphs shown in this datasheet are representing typical data only and do not show guaranteed values.
4. When using this product, please observe the absolute maximum ratings and the instructions for using outlined in these specification sheets. EVERLIGHT AMERICAS assumes no responsibility for any damage resulting from the use of the product which does not comply with the absolute maximum ratings and the instructions included in these specification sheets.
5. These specification sheets include materials protected under copyright of EVERLIGHT AMERICAS. Reproduction in any form is prohibited without obtaining EVERLIGHT AMERICAS's prior consent.
6. This product is not intended to be used for military, aircraft, automotive, medical, life sustaining or life saving applications or any other application which can result in human injury or death. Please contact authorized EVERLIGHT Americas sales agent for special application request.

EVERLIGHT