

XI3030P Color Series



Features

- Top view LED
- Wide viewing angle
- Pb-free
- RoHS compliant
- The product itself will remain within RoHS compliant version.
- Compliance with EU REACH.
- Compliance Halogen Free .(Br<900ppm,Cl<900ppm,Br+Cl<1500ppm)

Description

The Everlight XI3030P package has high efficacy, mid power consumption, wide viewing angle and a compact form factor. These features make this package an ideal LED for all lighting applications.

Applications

- Decorative and Entertainment Lighting
- Agriculture Lighting
- General use

Absolute Maximum Ratings

Parameter	Symbol	Ratings	Unit
Max. DC Forward Current (mA)	I_F	200	mA
Thermal Resistance	R_{th}	15	°C/W
Max. Junction Temperature	T_J	125/115 ^[1]	°C
Operating Temperature	T_{Opr}	-40 ~ +85	°C
Storage Temperature	T_{Stg}	-40 ~ +100	°C
Max. Soldering Temperature	T_{Sol}	260	°C
Max. Allowable Reflow Cycles	n/a	2	cycles

Notes:

1. For Far/Deep Red/Green/Amber/Orange/Red, the max. junction temperature=115°C. For Royal Blue, the max. junction temperature=125°C.

EVERLIGHT

PN of the XI3030P Color Series LEDs

Color	Order Code of XI3030P Color Series	Minimum Luminous Flux (lm)	Maximum Luminous Flux (lm)	Dominant Wavelength (nm)	Forward Voltage (V)	Current (mA)
Green	XI3030P/G3C-D1530P3R128371Z15/2N	33	55	515-530	2.8-3.7	150
Amber	XI3030P/Y3C-D8095L8N317281Z15/2N	17	27	580-595	1.7-2.8	150
Orange	XI3030P/O3C-D0520N3PB15281Z15/2N	24	45	605-620	1.5-2.8	150
Red	XI3030P/R3C-D1530L7N315281Z15/2N	16	27	615-630	1.5-2.8	150

Color	Order Code of XI3030P Color Series	Minimum Radiant Flux (mW)	Maximum Radiant Flux (mW)	Dominant Wavelength (nm)	Forward Voltage (V)	Current (mA)
Royal Blue	XI3030P/B3C-D5060T2T625312Z15/2N	190	280	450-460	2.5-3.1	150

Color	Order Code of XI3030P Color Series	Minimum Radiant Flux (mW)	Maximum Radiant Flux (mW)	Peak Wavelength (nm)	Forward Voltage (V)	Current (mA)
Deep Red	XI3030P/D3C-P4575S1S621271Z15/2N	100	160	645-675	2.1-2.7	150
Far Red	XI3030P/F3C-P1545R5S115251Z15/2N	70	110	715-745	1.4-2.5	150

Notes:

1. Luminous /Radiant Flux measurement tolerance: $\pm 10\%$.
2. The data of luminous flux measured at thermal pad= 25°C .
3. Typical luminous flux or light output performance is operated within the condition guided by this datasheet.

Product Binning

Luminous Flux Bins

Bin Code	Minimum Luminous Flux (lm)	Maximum Luminous Flux (lm)
L5	14	15
L6	15	16
L7	16	17
L8	17	18
L9	18	19
M3	19	21
M4	21	24
N3	24	27
N4	27	33
P3	33	36
PA	36	40
PB	40	45
QA	45	50
R1	50	55

Radiant Flux Bins

Bin Code	Minimum Radiant Flux (mW)	Maximum Radiant Flux (mW)
R4	65	70
R5	70	76
R6	76	83
R7	83	90
R8	90	100
S1	100	110
S2	110	120
S3	120	130
S4	130	140
S5	140	150
S6	150	160
S7	160	170
S8	170	180
T1	180	190
T2	190	200
T3	200	220
T4	220	240
T5	240	260
T6	260	280
T7	280	300

Notes:

1. Luminous / Radiant flux measurement tolerance: $\pm 10\%$.
2. Forward voltage bins are defined at $I_F=150\text{mA}$ operation.

Dominant /Peak Wavelength Bins

Group	Bin	Minimum Dominant Wavelength (nm)	Maximum Dominant Wavelength (nm)
B	51	450	455
	52	455	460
G	51	515	520
	52	520	525
	53	525	530
Y	51	580	585
	52	585	590
	53	590	595
O	52	605	610
	53	610	615
	54	615	620
R	51	620	625
	52	625	630

Group	Bin	Minimum Peak Wavelength (nm)	Maximum Peak Wavelength (nm)
D	51	640	645
	52	645	650
	53	650	655
	54	655	660
	55	660	665
	56	665	670
	57	670	675
F	A2	710	720
	A3	720	730
	A4	730	740
	A5	740	750

Notes:

1. Dominant/Peak Wavelength measurement tolerance: ± 1 nm.
2. Forward voltage bins are defined at $I_F=150$ mA operation.

Forward Voltage Bins

Bin	Minimum Forward Voltage (V)	Maximum Forward Voltage (V)
1415	1.4	1.5
1516	1.5	1.6
1617	1.6	1.7
1718	1.7	1.8
1819	1.8	1.9
1920	1.9	2.0
2021	2.0	2.1
2122	2.1	2.2
2223	2.2	2.3
2324	2.3	2.4
2425	2.4	2.5
2526	2.5	2.6
2627	2.6	2.7
2728	2.7	2.8
2829	2.8	2.9
2930	2.9	3.0
3031	3.0	3.1
3132	3.1	3.2
3233	3.2	3.3
3334	3.3	3.4
3435	3.4	3.5
3536	3.5	3.6
3637	3.6	3.7

Notes:

1. Forward voltage measurement tolerance: $\pm 2\%$.
2. Forward voltage bins are defined at $I_f=150\text{mA}$ operation.

Mechanical Dimension (Royal Blue)

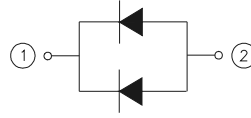
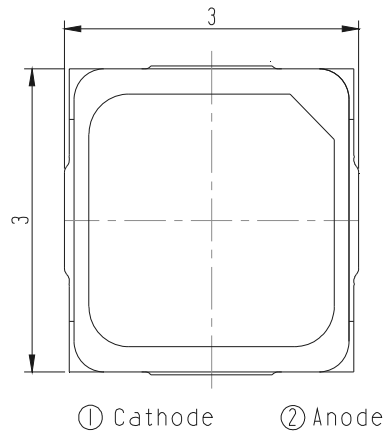

Polarity

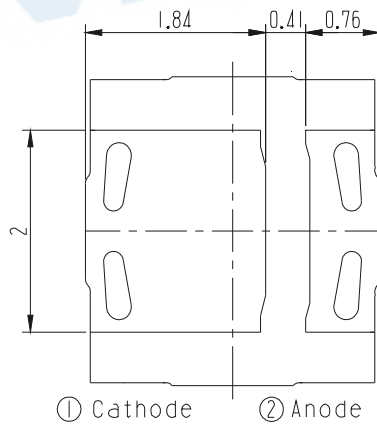
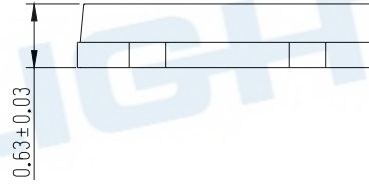
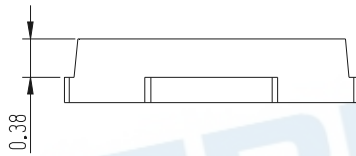

Bottom view

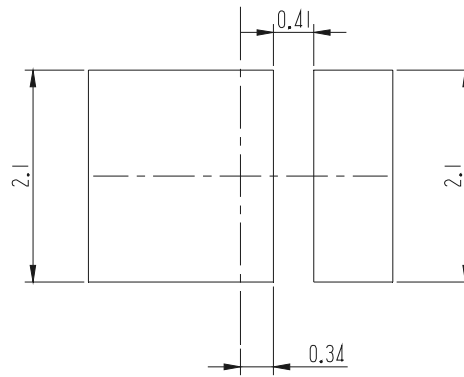

recommend solder pad

Notes:

1. Dimensions are in millimeters.
2. Tolerances unless mentioned are ± 0.2 mm.
3. The thermal pad is electrically unity from the Cathode and contact pads.
4. Do not handle the device by the lens. Incorrect force applied to the lens may lead to the failure of devices.

Mechanical Dimension (Green)

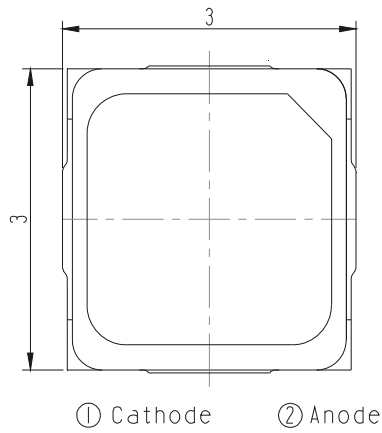

Polarity

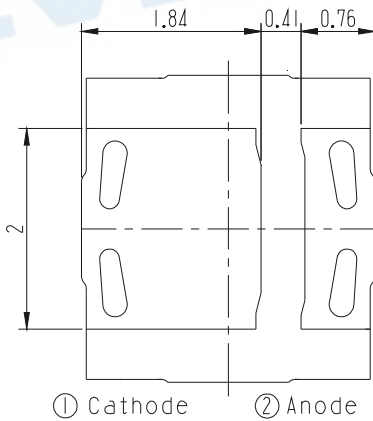
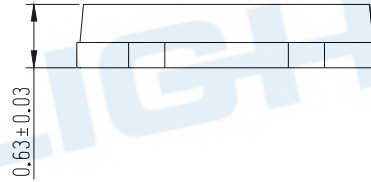
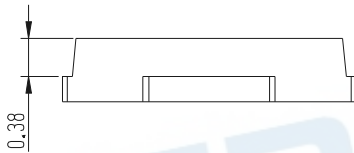

Bottom view

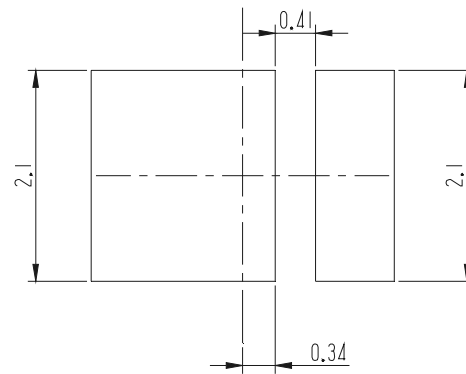

recommend solder pad

Notes:

1. Dimensions are in millimeters.
2. Tolerances unless mentioned are $\pm 0.2\text{mm}$.
3. The thermal pad is electrically unity from the Cathode and contact pads.
4. Do not handle the device by the lens. Incorrect force applied to the lens may lead to the failure of devices.

Mechanical Dimension (Far Red/Deep Red/Amber/Orange/Red)

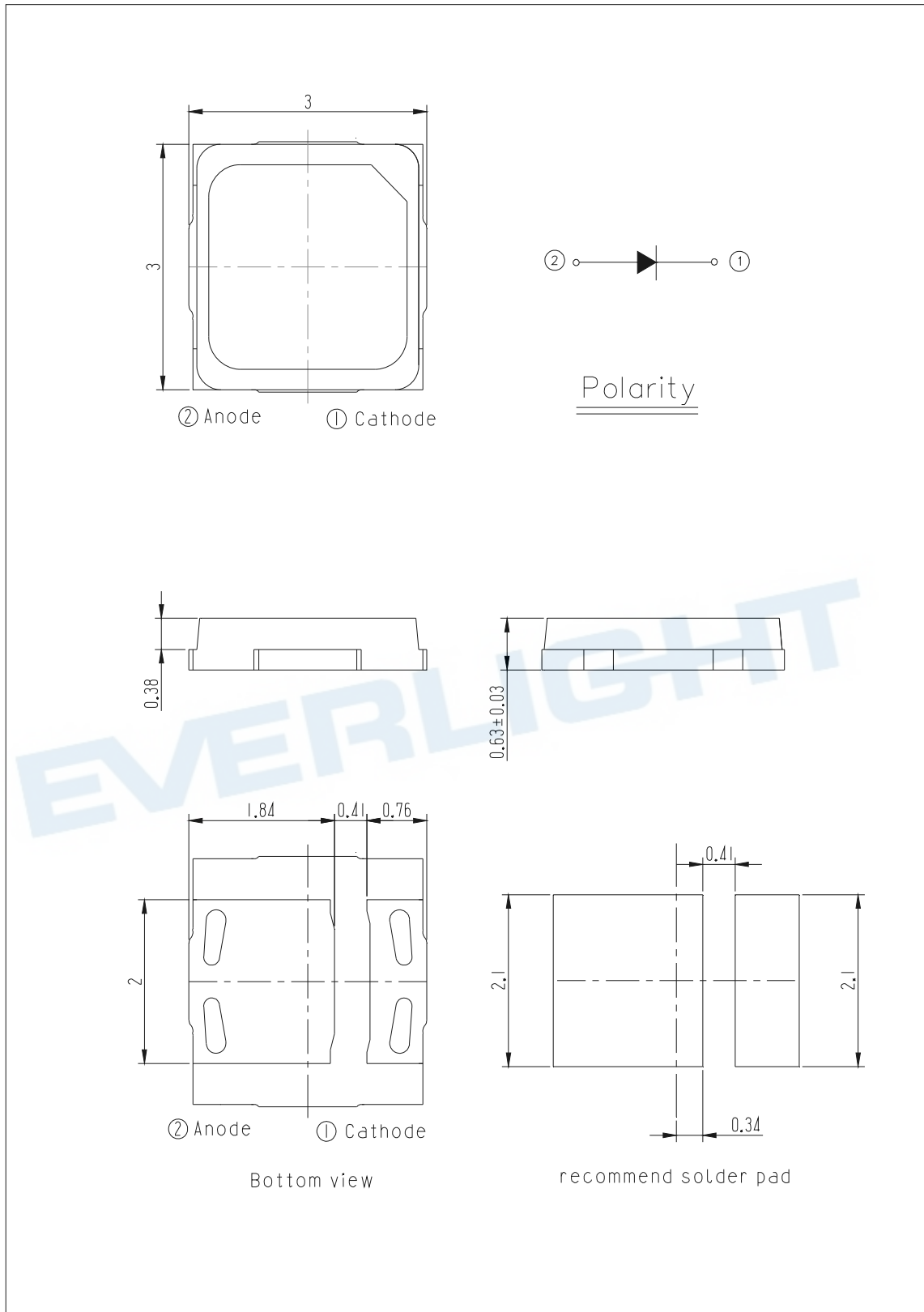

Notes:

1. Dimensions are in millimeters.
2. Tolerances unless mentioned are $\pm 0.2\text{mm}$.
3. The thermal pad is electrically unity from the Anode and contact pads.
4. Do not handle the device by the lens. Incorrect force applied to the lens may lead to the failure of devices.

Wavelength Characteristics

Relative Spectral Distribution
@ Solder Pad Temperature = 25°C

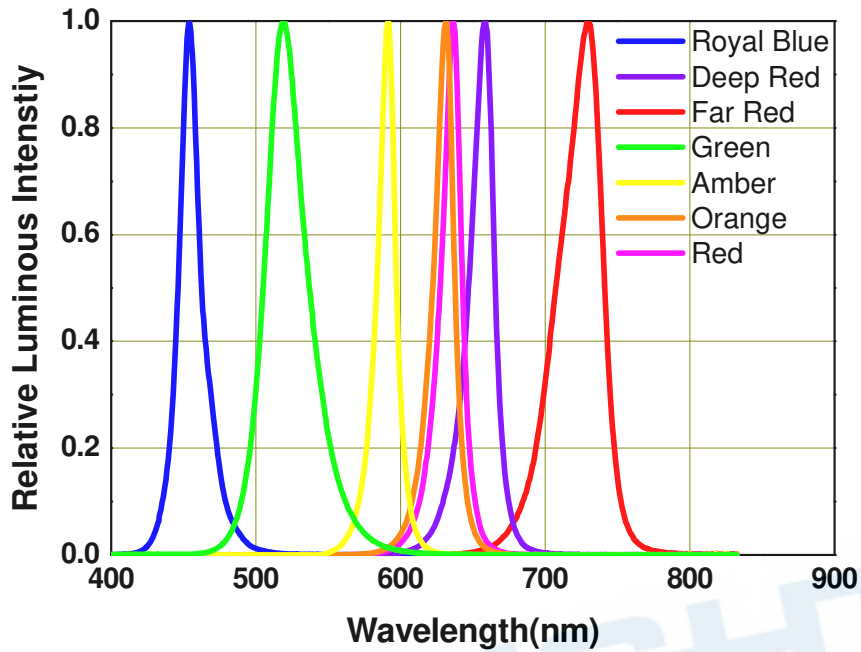

Forward Voltage vs. Forward Current

@ Solder Pad Temperature = 25°C

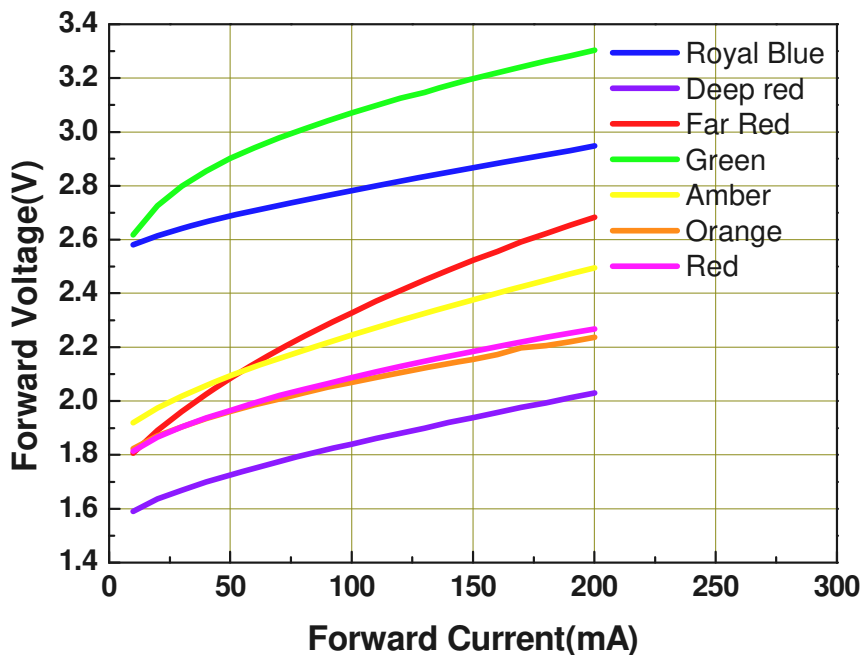

Relative Luminous Intensity vs. Forward Current

@ Solder Pad Temperature = 25°C

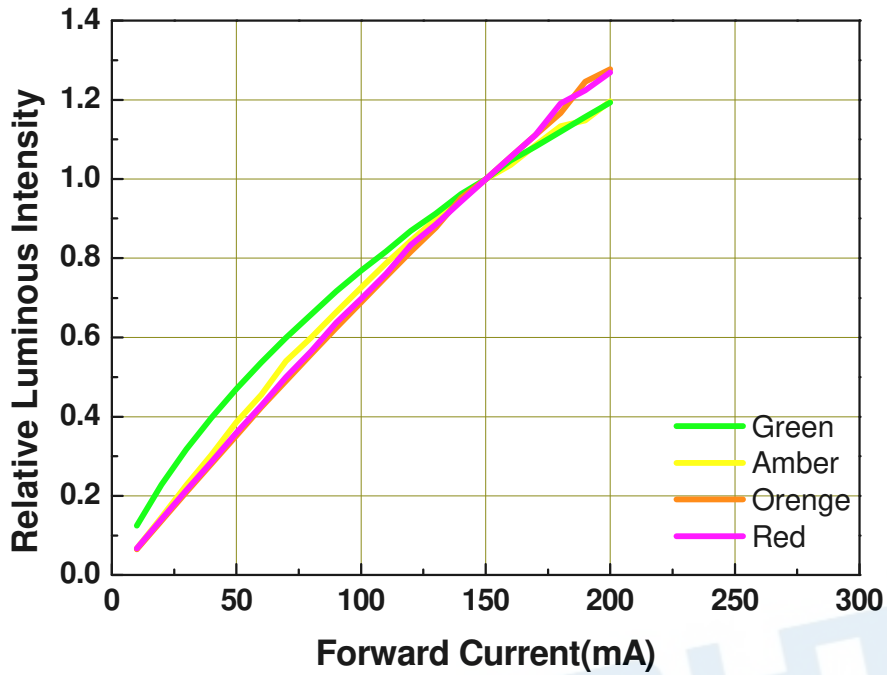

Relative Radiant Intensity vs. Forward Current

@ Solder Pad Temperature = 25°C

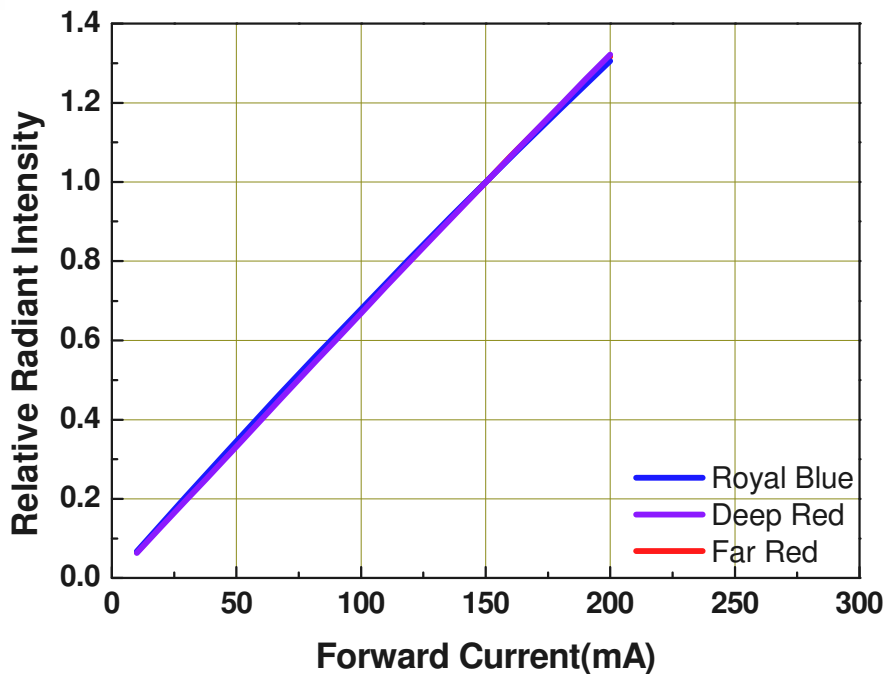

Dominant Wavelength vs. Forward Current

@ Solder Pad Temperature = 25°C

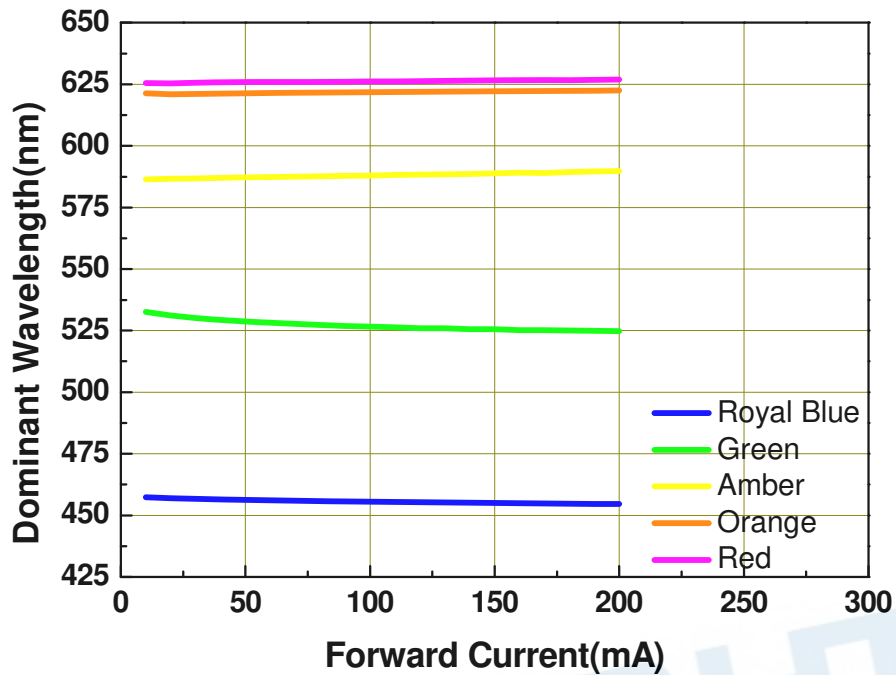

Peak Wavelength vs. Forward Current

@ Solder Pad Temperature = 25°C

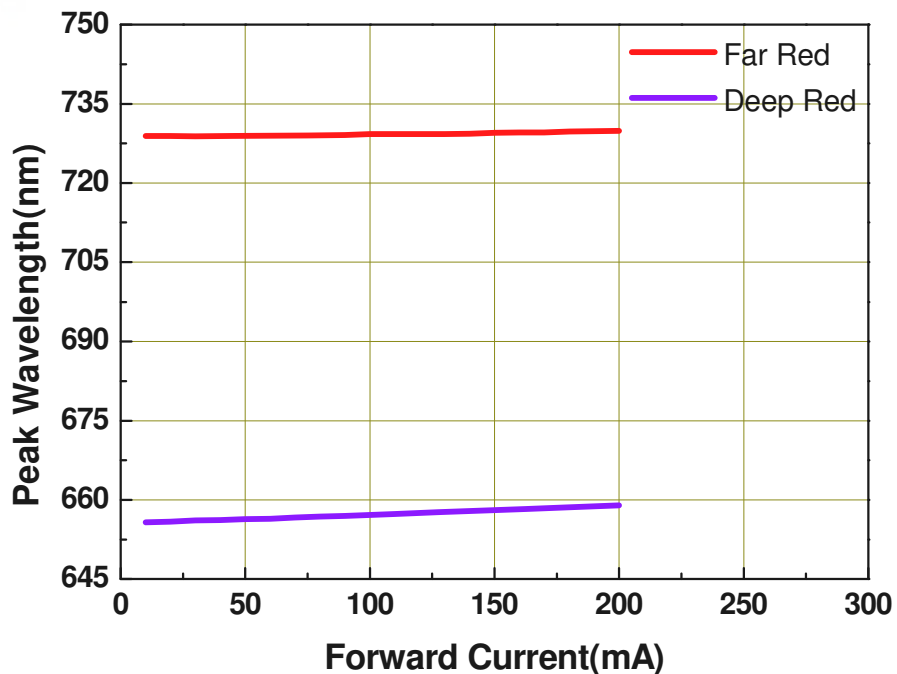

Relative Luminous Intensity vs. Junction Temperature

@Forward Current = 150mA

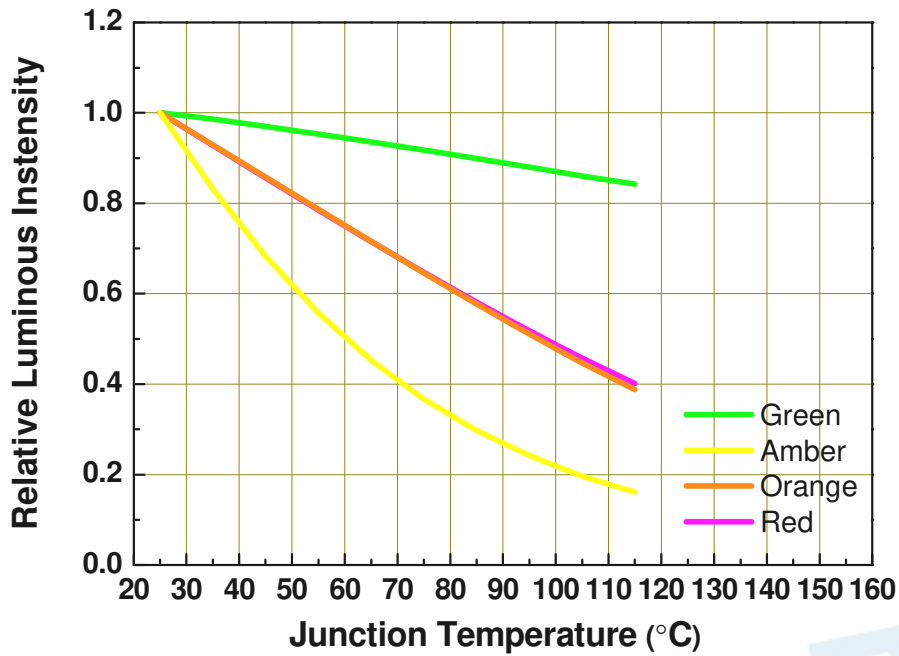

Relative Radiant Intensity vs. Junction Temperature

@Forward Current = 150mA

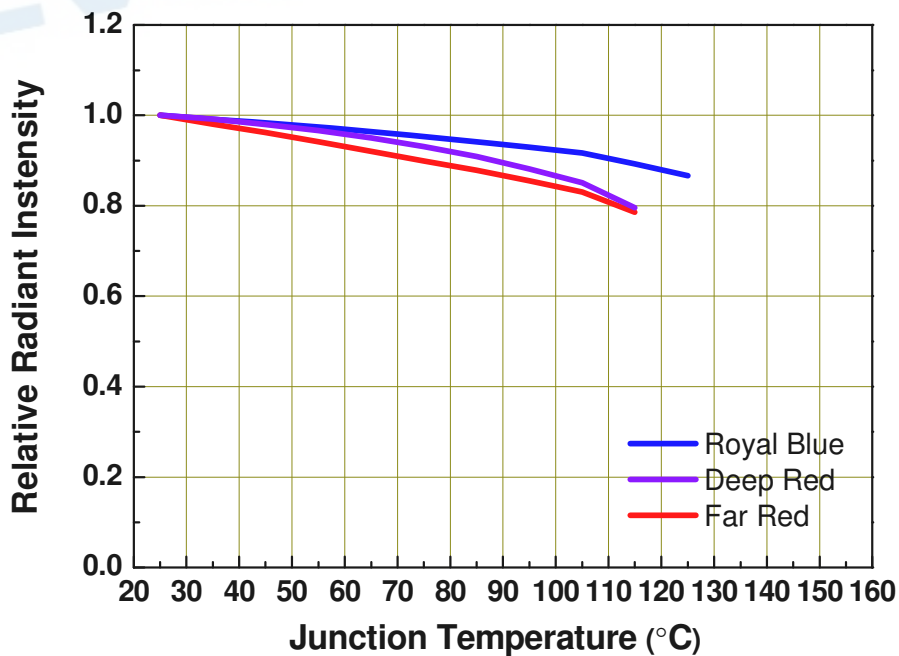

Forward Voltage vs. Junction Temperature

@Forward Current = 150mA

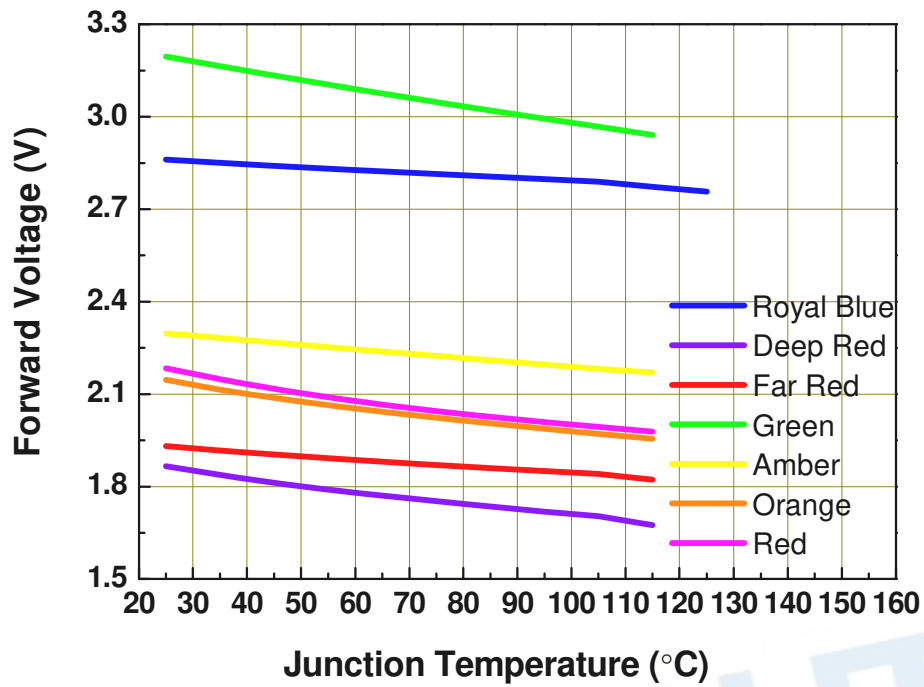

Dominant Wavelength vs. Junction Temperature

@Forward Current = 150mA

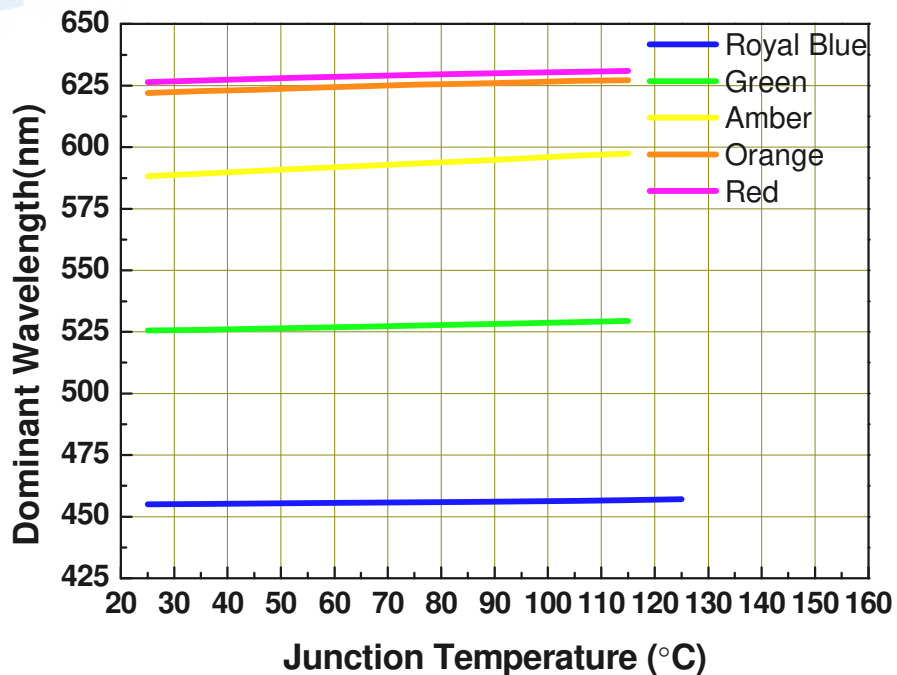

Peak Wavelength vs. Junction Temperature

@Forward Current = 150mA

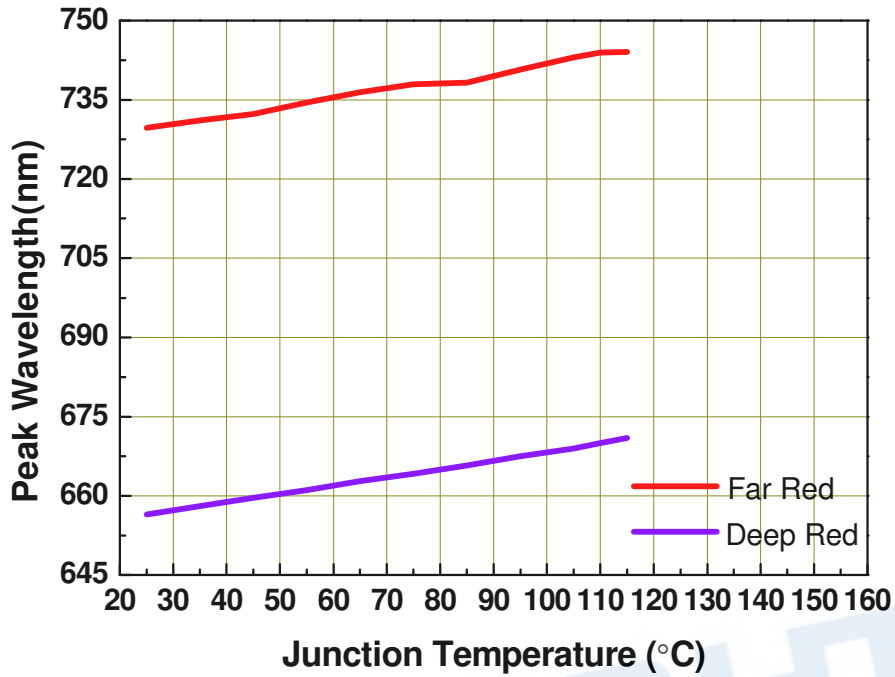

Forward Current Derating Curve

@ Junction Temperature <125/115°C [1]

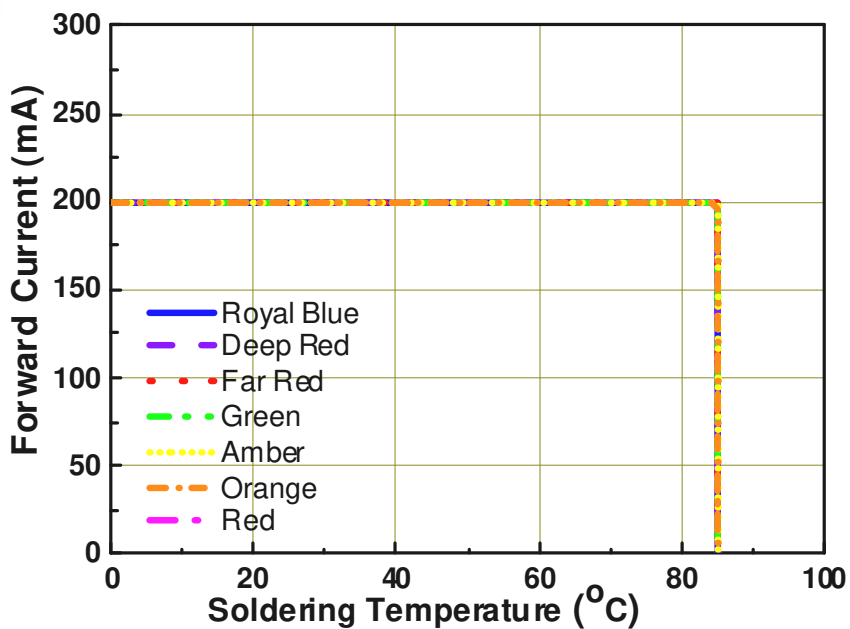

Notes:

1. For Far/Deep Red/Green/Amber/Orange/Red, the max. junction temperature=115°C. For Royal Blue, the max. junction

Typical Radiation Patterns

Typical Diagram Characteristics of Radiation

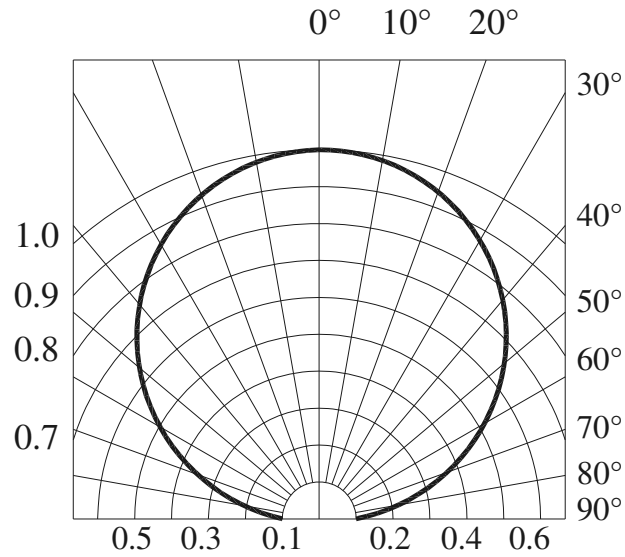

Notes:

1. $2\theta_{1/2}$ is the off axis angle from lamp centerline where the luminous intensity is 1/2 of the peak value.
2. View angle tolerance is $\pm 5^\circ$.

Emitter Tape Packaging

Carrier Tape Dimensions as the following (Royal Blue):

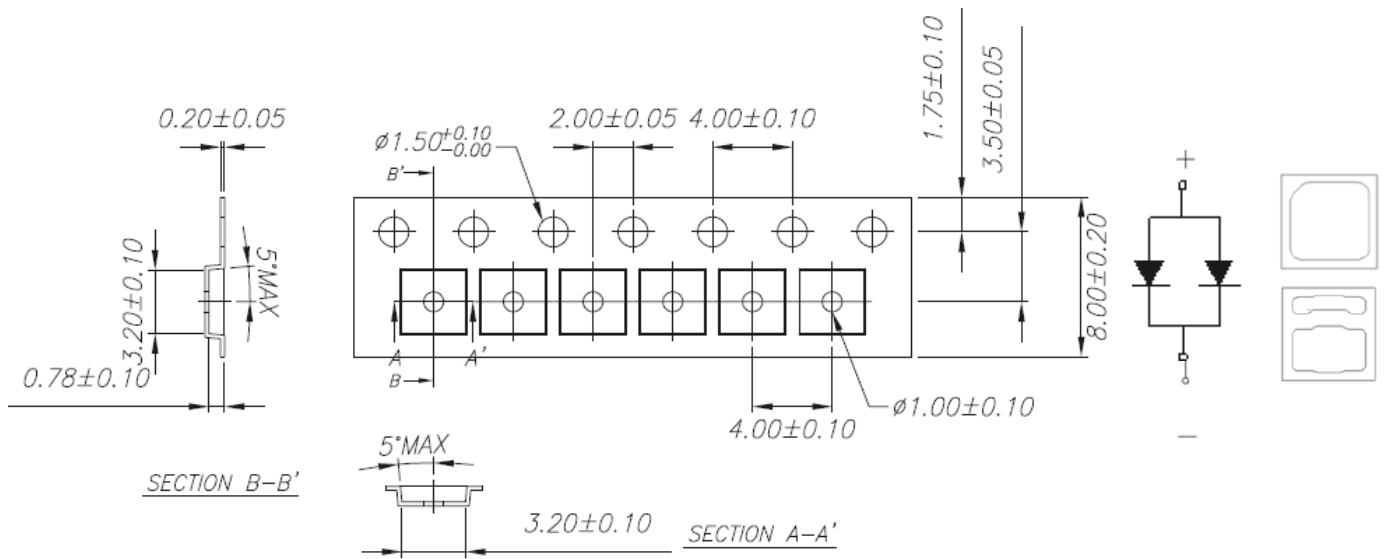

Carrier Tape Dimensions as the following (Green):

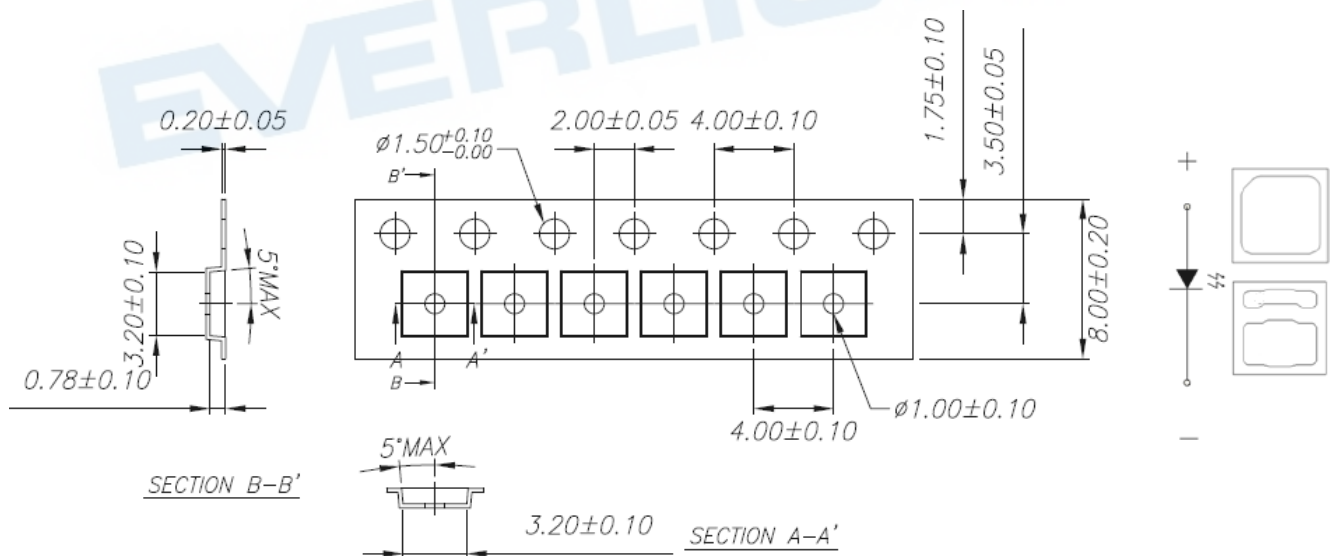

Notes:

1. Tolerance unless mentioned is ± 0.1 mm; Unit = mm
2. Minimum packing amount is 250/500/1000/2000 pcs per reel

Carrier Tape Dimensions as the following (Far Red/Deep Red/Amber/Orange/Red):

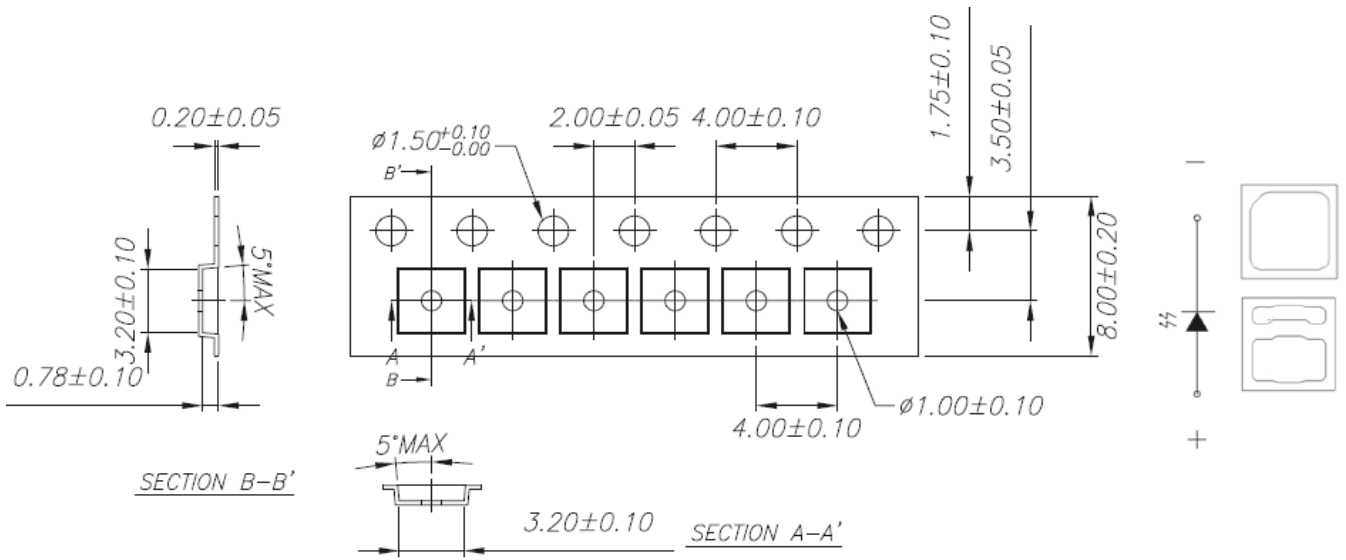

Notes:

1. Tolerance unless mentioned is $\pm 0.1 \text{ mm}$; Unit = mm
2. Minimum packing amount is 250/500/1000/2000 pcs per reel

Emitter Reel Packaging

Moisture Resistant Packaging

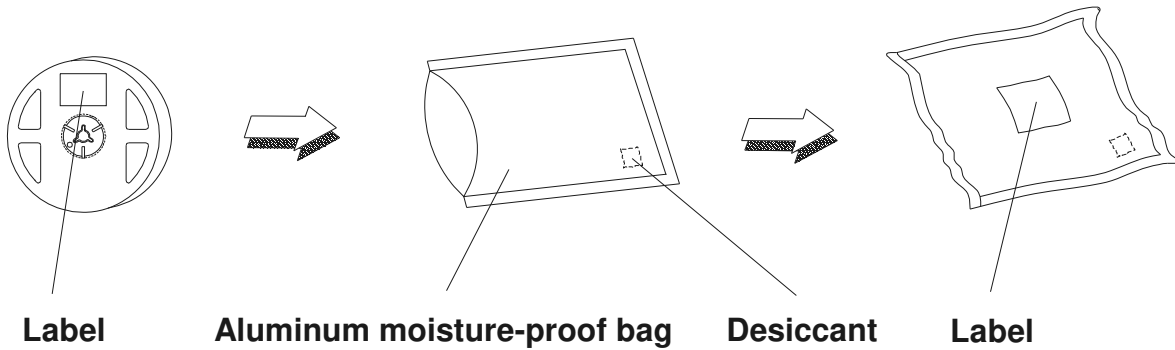

Reel Dimensions

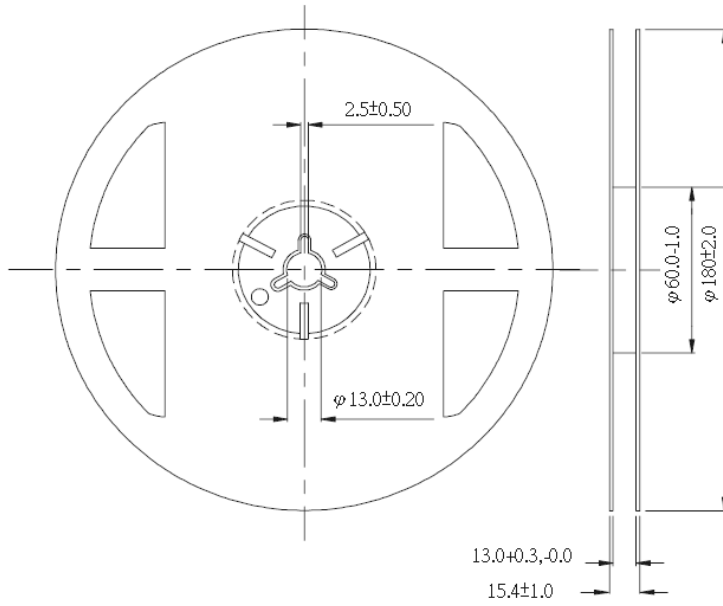

Notes:

1. Dimensions are in millimeters.
2. Tolerances unless mentioned are ± 0.1 mm.

EVERLIGHT

Product Labeling

Label Explanation

CPN: Customer Specification (when required)

P/N : Everlight Production Number

QTY: Packing Quantity

CAT: Luminous Flux (Brightness) Bin

HUE: Color Bin

REF: Forward Voltage Bin

LOT No: Lot Number

MADE IN TAIWAN: Production Place

RoHS (Pb) **EVERLIGHT** 5

CPN: XXXXXXXXXXXXXXXXXXXXXXXX



XXXXXXXXXX-XXXXXXXXXX-XXXXXXXXXX-XXXXXXXXXX-XXXXXX

P/N: XXXXXXXXXXXXX



XXXXXXXXXX-XXXXXXXXXX-XXXXXXXXXX-XXXXXXXXXX-XXXXXX

LOT NO: Y150716XXX-XXXXXXXXXX-XXXXXXXXXX

QTY: 0123456789 HUE: XXXXXXXXXXXX

CAT: XXXXXXXXXXXX REF: XXXXXXXXXXXX

XXXXXXXXXX REF: XXXXXXXXXXXX

REFERENCE: BTPYYMDDXXXXX

XXXXXXXXXX

XXXXXXXXXX

XXXXXXXXXX

XXXXXXXXXX

XXXXXXXXXX

MADE IN XXXXXXXX



Precautions for Use

1. Over-current-proof

Customer must apply resistors for protection; otherwise slight voltage shift will cause big current change (Burn out will happen).

2. Assemblies

Do not stack assemblies containing Everlight XI3030 LEDs to prevent damage to the optical surface of LEDs. Forces applied to the optical surface may result in the surface being damaged.

3. Soldering Condition

3.1 Pb-free solder temperature profile

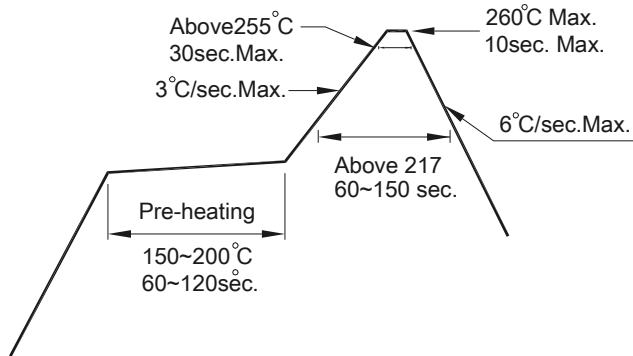

3.2 Reflow soldering should not be done more than two times.

3.3 When soldering, do not put stress on the LEDs during heating.

3.4 After soldering, do not warp the circuit board.

4. Soldering Iron

Each terminal is to go to the tip of soldering iron temperature less than 350°C for 3 seconds within once in less than the soldering iron capacity 25W. Leave two seconds and more intervals, and do soldering of each terminal. Be careful because the damage of the product is often started at the time of the hand solder.

5. Repairing

Repair should not be done after the LEDs have been soldered. When repairing is unavoidable, a double-head soldering iron should be used (as below figure). It should be confirmed beforehand whether the characteristics of the LEDs will or will not be damaged by repairing.

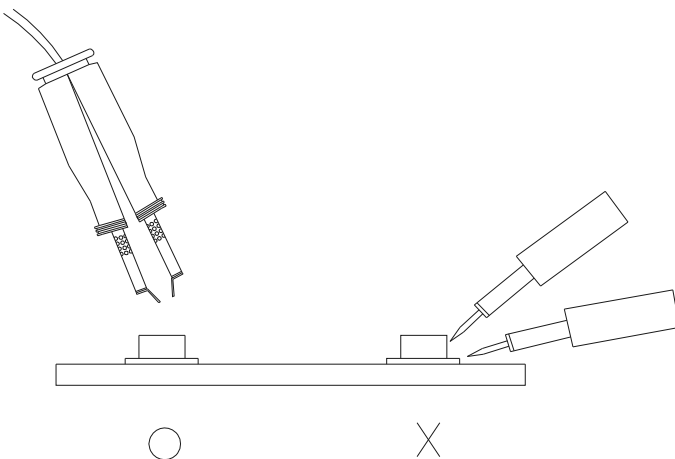

Storage Conditions

- Before the package is opened. The LEDs should be stored at 30°C or less and 90%RH or less after being shipped from EVERLIGHT and the storage life limits are 12 months.
- If the moisture absorbent material (silica gel) has faded away or the LEDs have exceeded the storage time, baking treatment should be performed using the following conditions. Baking treatment: 60±5°C for 24 hours.

DISCLAIMER

- EVERLIGHT reserves the right(s) on the adjustment of product material mix for the specification.
- The product meets EVERLIGHT published specification for a period of twelve (12) months from date of shipment.
- The graphs shown in this datasheet are representing typical data only and do not show guaranteed values.
- When using this product, please observe the absolute maximum ratings and the instructions for using outlined in these specification sheets. EVERLIGHT assumes no responsibility for any damage resulting from the use of the product which does not comply with the absolute maximum ratings and the instructions included in these specification sheets.
- These specification sheets include materials protected under copyright of EVERLIGHT. Reproduction in any form is prohibited without obtaining EVERLIGHT's prior consent.
- This product is not intended to be used for military, aircraft, automotive, medical, life sustaining or life saving applications or any other application which can result in human injury or death. Please contact authorized EVERLIGHT sales agent for special application request.

Revision History

Current version: 04.30.2019
Issue No: DHE-0003239
Version:3

Page	Subjects (major change in previous version)	Date of change
	Modified Royal blue's bin	03/09/2017
P3-P4	1. Modified G3C/O3C/Y3C Product name and Luminous Flux Bins	01/11/2019
P16	2. Typical Radiation Patterns	
P3	Modified new PN	04/30/2019

EVERLIGHT