

## SMD ▪ MID Power LED XI3030PF/KK8C-5MXXXX28U6/2N

### Features

- PLCC-2 package
- Top view white LED
- High luminous intensity output
- Wide viewing angle
- Pb-free
- ANSI Binning
- The product itself will remain within RoHS compliant version.
- Compliance with EU REACH.
- Compliance Halogen Free .(Br<900ppm,Cl<900ppm,Br+Cl<1500ppm)

### Description

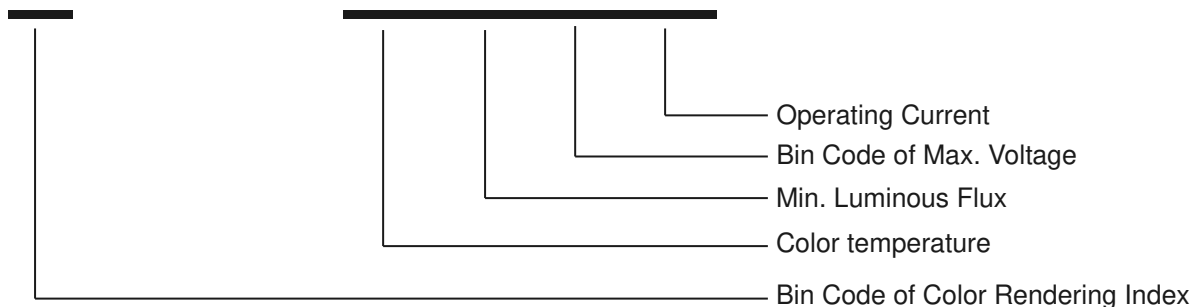
The Everlight XI3030PF package has high efficacy, mid power consumption, wide viewing angle and a compact form factor. These features make this package an ideal LED for all lighting applications.

### Applications

- General lighting
- Decorative and Entertainment Lighting
- Indicators
- Illumination
- Switch lights

### Product Number Explanation

**XI3030PF/ K K8C - 5M XX XX XX U6 / 2 N**



### Table of Color Rendering Index

Symbol	Description
M	CRI(Min.) : 60
N	CRI(Min.) : 65
L	CRI(Min.) : 70
Q	CRI(Min.) : 75
K	CRI(Min.) : 80
P	CRI(Min.) : 85
H	CRI(Min.) : 90
R	CRI(Min.) : 90, R9(Min.) : 50

Note:  
Tolerance of Color Rendering Index: ±2

### Table of Forward Current Index

Symbol	Description
U6	I <sub>F</sub> :65mA

### Table of Forward Voltage Index

Symbol	Description
28	2.8V max

Example:  
XI3030PF/KK8C-5M404028U6/2N

CRI	80(Min.)
CCT	4000K
Flux	40lm min
V <sub>F</sub>	2.8V max
I <sub>F</sub>	65mA

## Mass Production List

CCT(K)	Product	CRI Min.(1)	65mA $\Phi$ (lm) Min. (2)	150mA $\Phi$ (lm) Min. (2)	350mA $\Phi$ (lm) Min. (2)	VF Max. (3)	65mA Efficacy(lm/w) Typ.	65mA PPF(umol/s)Typ.	PPE(umol/s/W) Typ.
3000	XI3030PF/KK8C-5M303828U6/2N	80	38	80	170	2.8	220	0.546	3.15
4000	XI3030PF/KK8C-5M404028U6/2N	80	40	85	185	2.8	230	0.557	3.20
5000	XI3030PF/KK8C-5M504028U6/2N	80	40	85	185	2.8	230	0.554	3.21
6500	XI3030PF/KK8C-5M653928U6/2N	80	39	80	175	2.8	227	0.565	3.25

Notes:

1. Tolerance of Color Rendering Index:  $\pm 2$
2. Tolerance of Luminous flux:  $\pm 11\%$ .
3. Tolerance of Forward Voltage:  $\pm 0.1V$

EVERLIGHT

## Device Selection Guide

Chip Materials	Emitted Color	Resin Color
InGaN	Cool White Neutral White Warm White	Water Clear

## Absolute Maximum Ratings (T<sub>Soldering</sub>=25°C)

Parameter	Symbol	Rating	Unit
Forward Current	I <sub>F</sub>	350	mA
Peak Forward Current (Duty 1/10 @10ms)	I <sub>FP</sub>	420	mA
Power Dissipation	P <sub>d</sub>	980	mW
Operating Temperature	T <sub>opr</sub>	-40 ~ +100	°C
Storage Temperature	T <sub>stg</sub>	-40 ~ +100	°C
Thermal Resistance (Junction / Soldering point)	R <sub>th J-S</sub>	7.5	°C/W
Junction Temperature	T <sub>j</sub>	115	°C
Soldering Temperature	T <sub>sol</sub>	Reflow Soldering : 260 °C for 10 sec. Hand Soldering : 350 °C for 3 sec.	

### Note:

The products are sensitive to static electricity and must be carefully taken when handling products

## Electro-Optical Characteristics (T<sub>Soldering</sub>=25°C)

Parameter	Symbol	Min.	Typ.	Max.	Unit	Condition
Luminous Flux <sub>(1)</sub>	Φ	38	-----	43	lm	I <sub>F</sub> =65mA
Forward Voltage <sub>(2)</sub>	V <sub>F</sub>	2.6	-----	2.8	V	I <sub>F</sub> =65mA
Color Rendering Index <sub>(3)</sub>	Ra	80	----	----		I <sub>F</sub> =65mA
Viewing Angle	2θ <sub>1/2</sub>	-----	120	-----	deg	I <sub>F</sub> =65mA
Reverse Current	IR	-----	-----	50	μA	V <sub>R</sub> =5V

1. Tolerance of Luminous flux: ±11%.
2. Tolerance of Forward Voltage: ±0.1V
3. Tolerance of Color Rendering Index: ±2

### Bin Range of Luminous Flux 3000k

Bin Code	Min.	Max.	Unit	Condition
38L2	38	40	lm	I <sub>F</sub> =65mA
40L2	40	42		

### 4000k/5000k

Bin Code	Min.	Max.	Unit	Condition
40L2	40	42	lm	I <sub>F</sub> =65mA
42L2	42	44		

### 6500k

Bin Code	Min.	Max.	Unit	Condition
39L2	39	41	lm	I <sub>F</sub> =65mA
41L2	41	43		

Note:

Tolerance of Luminous flux:  $\pm 11\%$ .

### Bin Range of Forward Voltage

Group	Bin Code	Min.	Max.	Unit	Condition
2628	26A	2.6	2.7	V	I <sub>F</sub> =65mA
	27A	2.7	2.8		

Note:

Tolerance of Forward Voltage:  $\pm 0.1V$ .

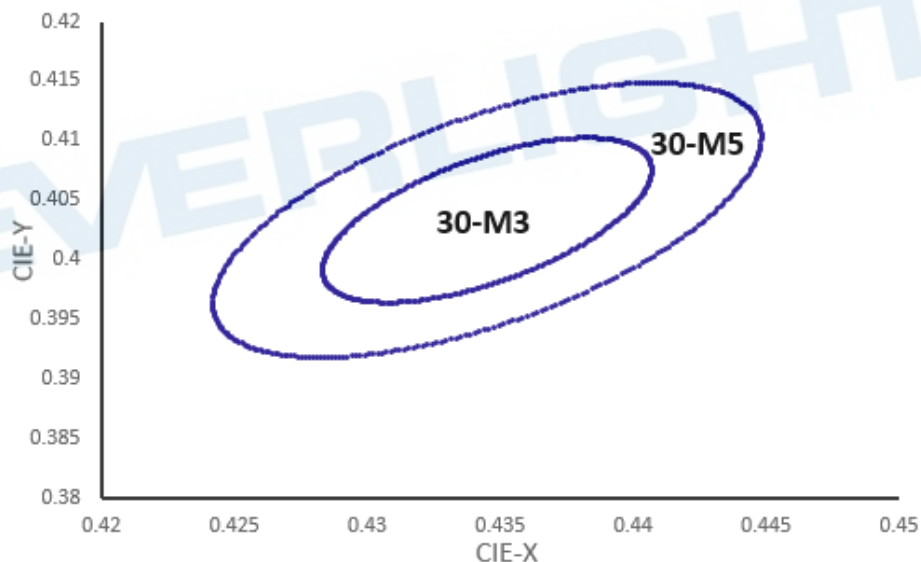
### Bin Code of Macadam 3 step

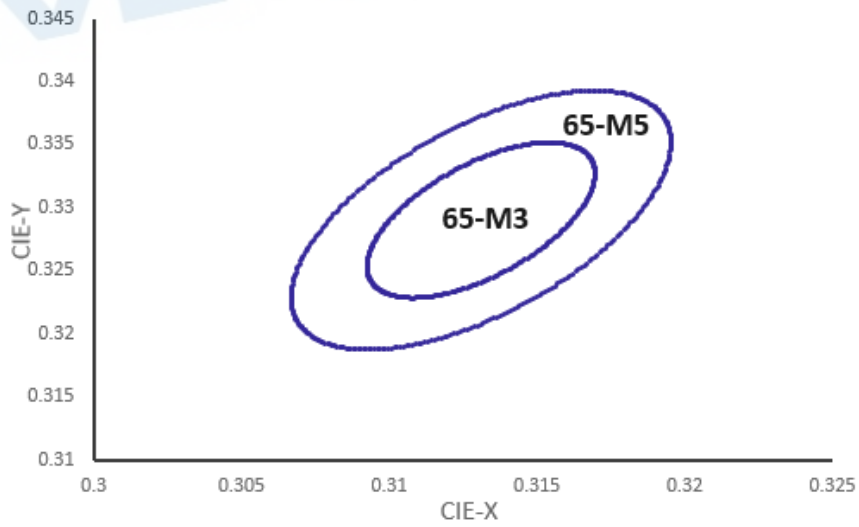
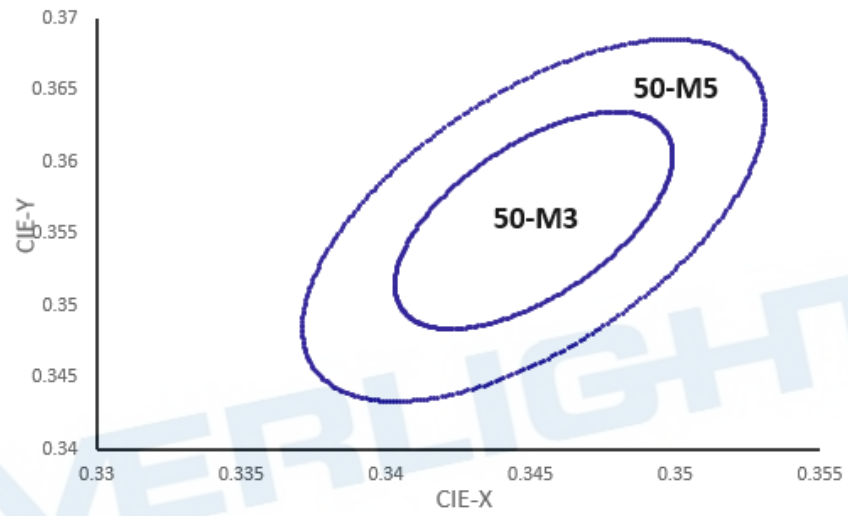
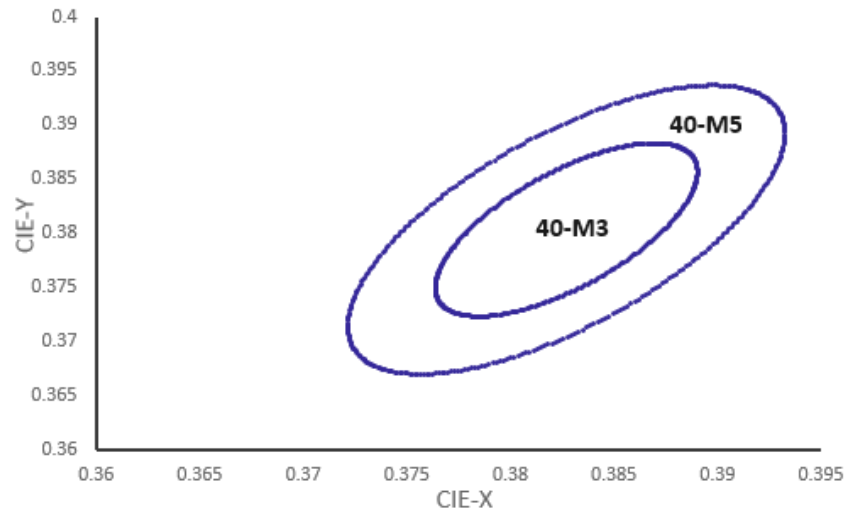
Step	CCT	Cx	Cy	a	b	theta
3	3000K	0.4345	0.4033	0.00834	0.00408	50.22
	4000K	0.3827	0.3803	0.00939	0.00402	54.8
	5000K	0.3451	0.3559	0.00822	0.00354	64.12
	6500K	0.3131	0.329	0.00669	0.00285	64.57

### Bin Code of Macadam 5 step

Step	CCT	Cx	Cy	a	b	theta
5	3000K	0.4345	0.4033	0.0139	0.0068	50.22
	4000K	0.3827	0.3803	0.01565	0.0067	54.8
	5000K	0.3451	0.3559	0.0137	0.0059	64.12
	6500K	0.3131	0.329	0.01115	0.00475	64.57

### The C.I.E. 1931 Chromaticity Diagram

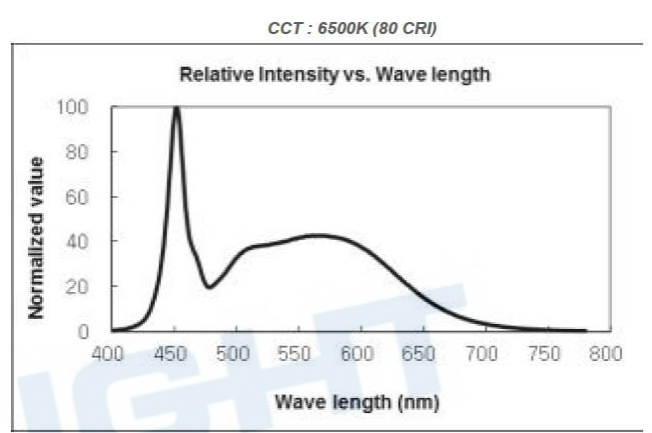
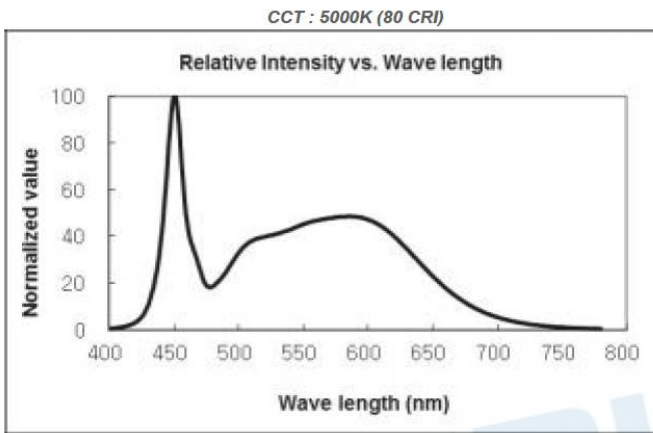
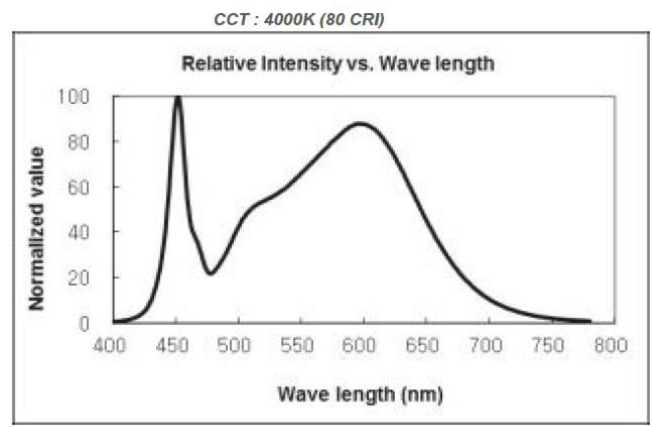
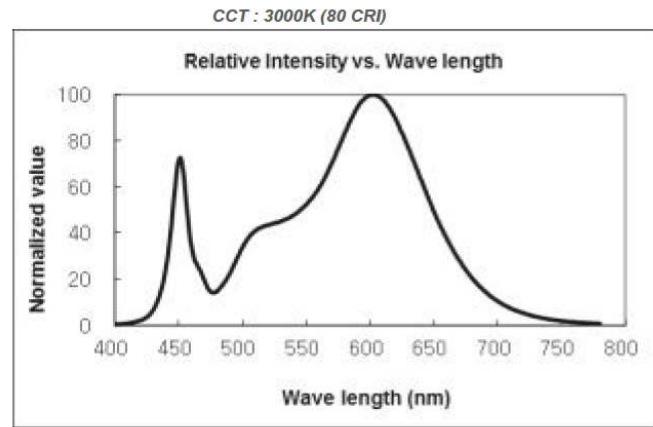




Note:

1. The value is based on driving current by 65mA.
2. Tolerance of Chromaticity Coordinates:  $\pm 0.01$ .

## Spectrum Distribution



## Typical Electro-Optical Characteristics Curves

Fig.1 – Forward Voltage Shift vs. Junction Temperature

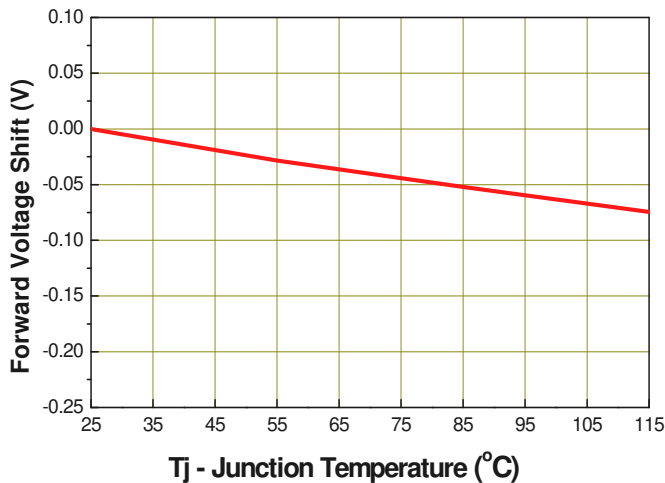
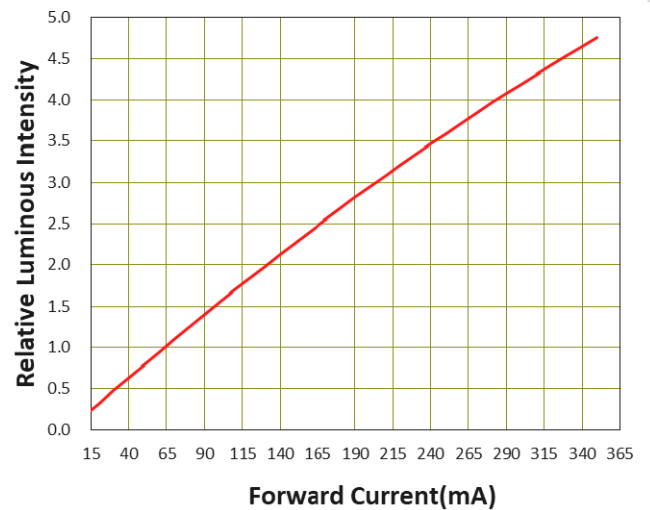
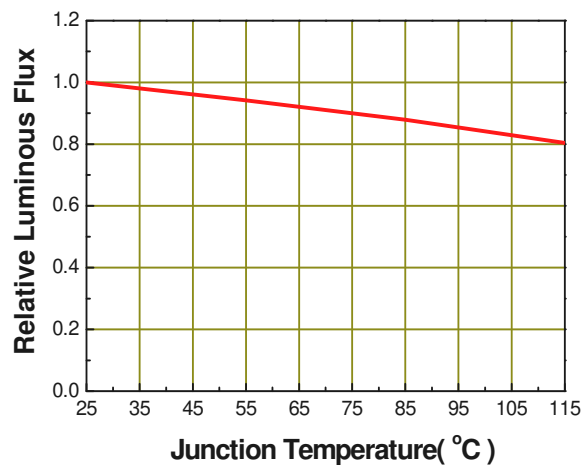


Fig.2 - Relative Luminous Intensity vs. Forward Current

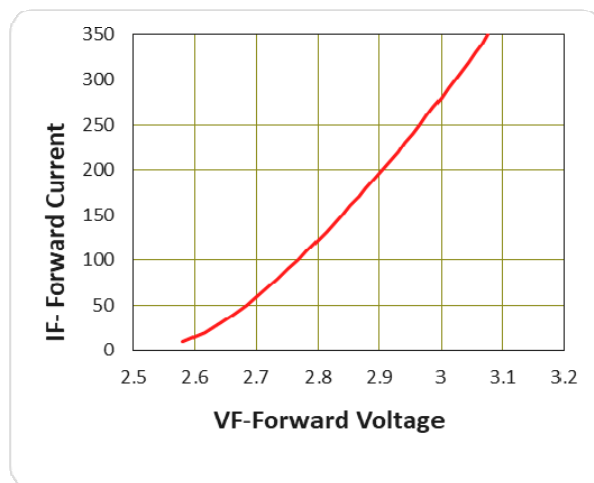


## Typical Electro-Optical Characteristics Curves

**Fig.3 - Relative Luminous Intensity vs. Junction Temperature**

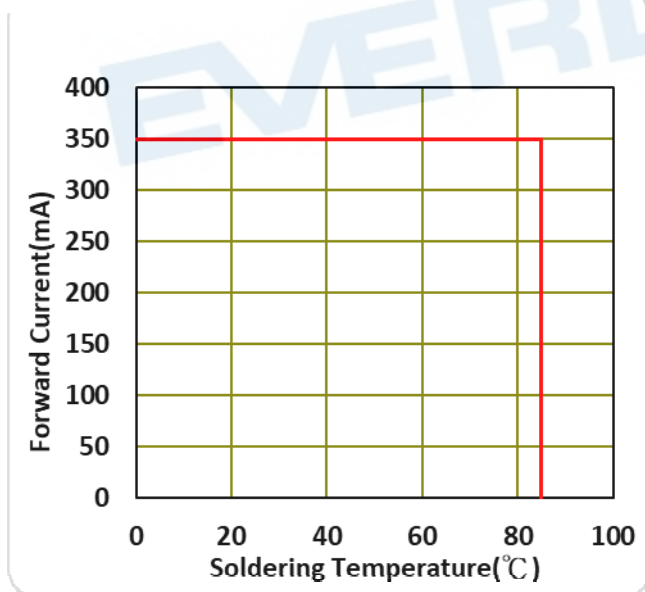


**Fig.4 - Forward Current vs. Forward Voltage**

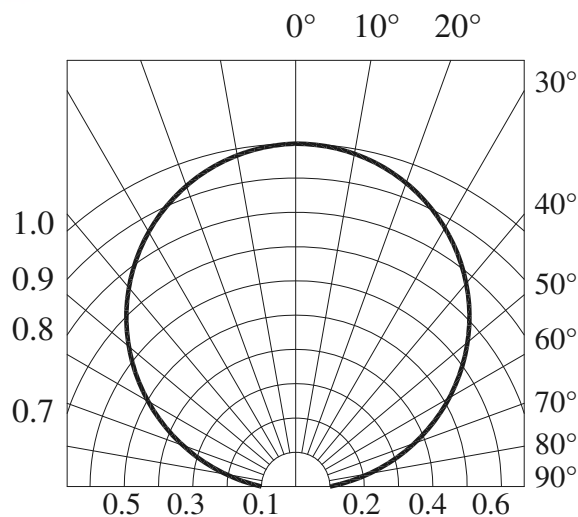


**Fig.5 – Max. Driving Forward Current vs. Soldering Temperature**

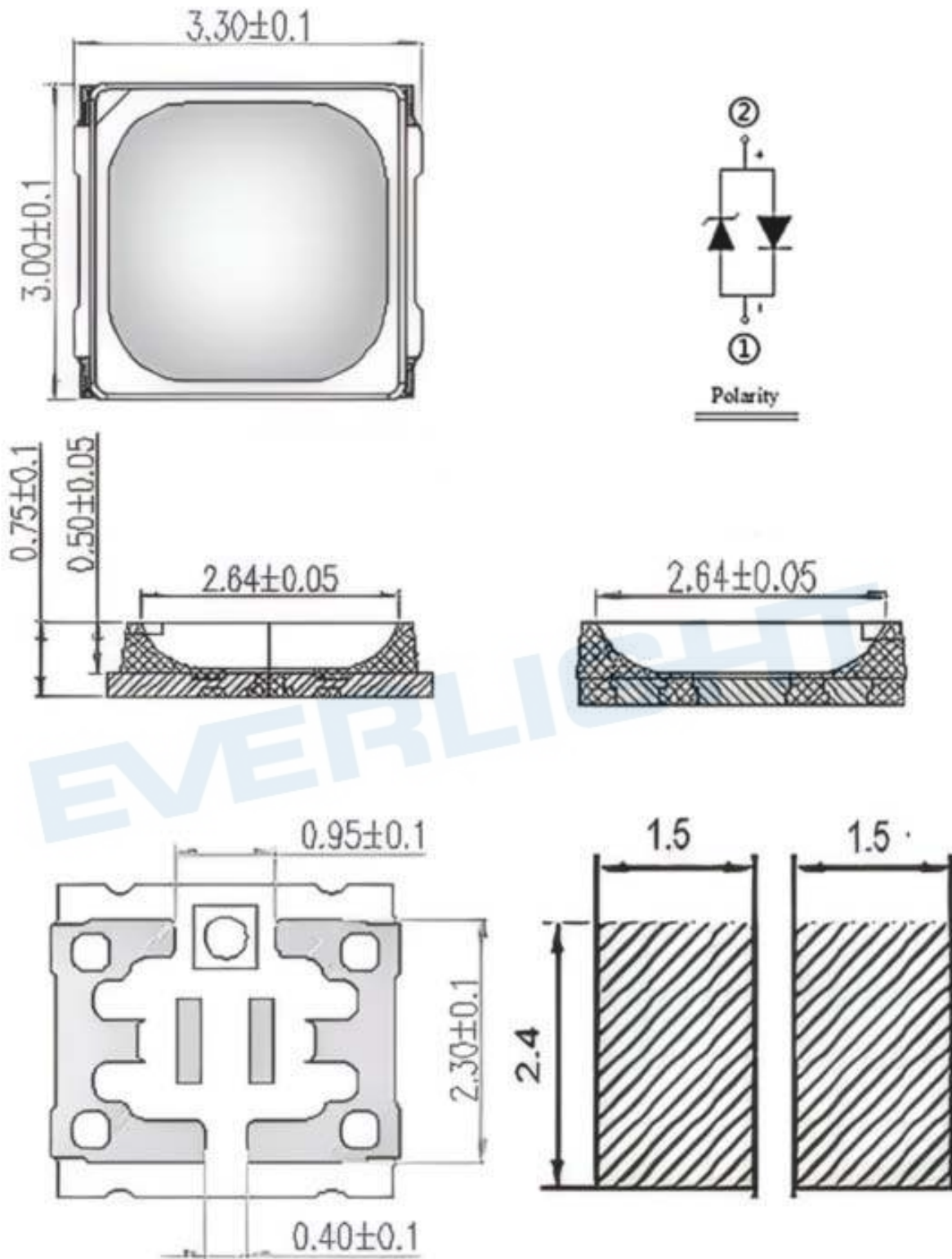
$R_{th\ j-s} = 7.5\ ^\circ\text{C/W}$



**Fig.6 – Radiation Diagram**



## Package Dimension



### Notes:

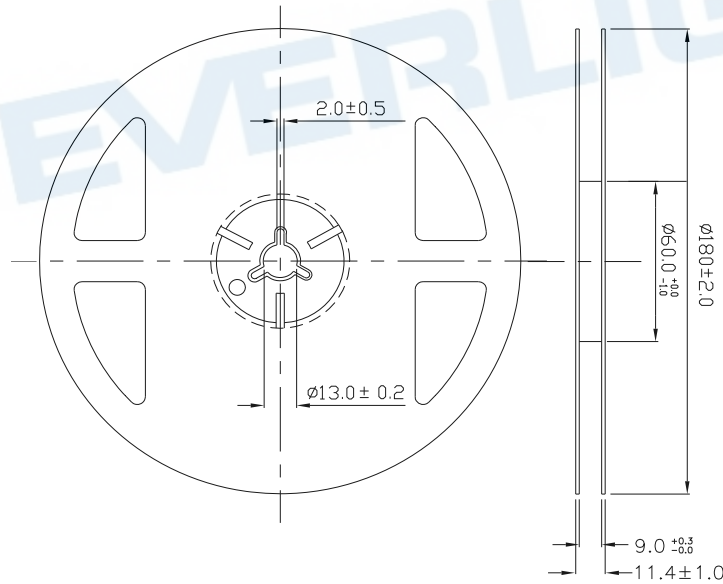
1. Dimensions are in millimeters.
2. Tolerances unless mentioned are  $\pm 0.2$ mm.

### Moisture Resistant Packing Materials

1. CPN: Customer Specification (when required)
2. P/N : Everlight Production Number
3. QTY: Packing Quantity
4. CAT: Luminous Flux (Brightness) Bin
5. HUE: Color Bin
6. REF: Forward Voltage Bin
7. LOT No: Lot Number

RoHS	<b>EVERLIGHT</b>	<b>5</b>
CPN : XXXXXXXXXXXXXXXXXXXXXXXX		
XXXXXXXXXX-XXXXXXXXXX-XXXXXXXXXX-XXXXXXXXXX-XXXXXX		
P/N : XXXXXXXXXXXX		
XXXXXXXXXX-XXXXXXXXXX-XXXXXXXXXX-XXXXXXXXXX-XXXXXX		
LOT NO: Y150716XXX-XXXXXXXXXX-XXXXXXXXXX		
QTY: 0123456789    HUE: XXXXXXXXXXXX		
CAT: XXXXXXXXXXXX    REF: XXXXXXXXXXXX		
REFERENCE: BTPYYMDDXXXXXX		

### Reel Dimensions

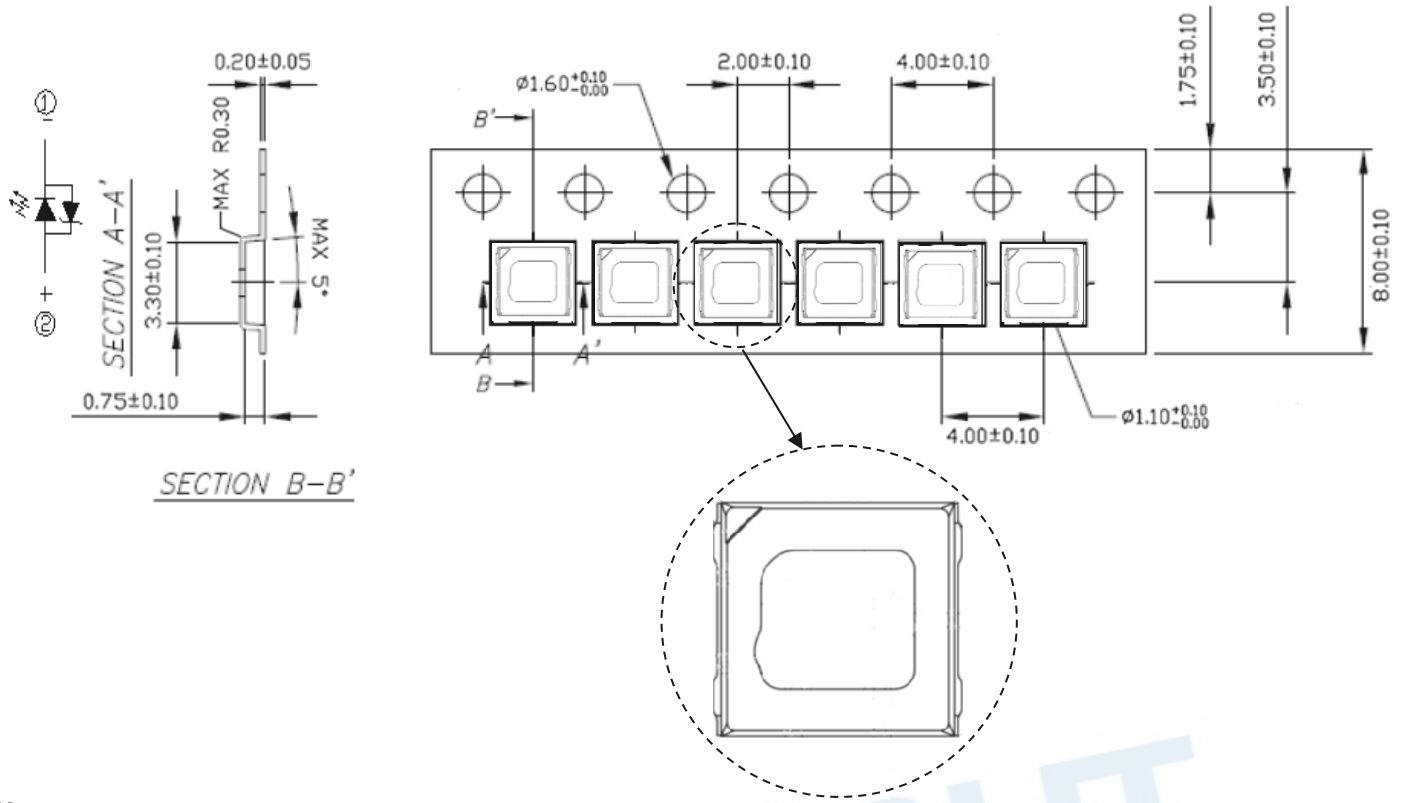


**Notes:**

1. Dimensions are in millimeters.
2. Tolerances unless mentioned are  $\pm 0.1$  mm.

**Carrier Tape Dimensions:**

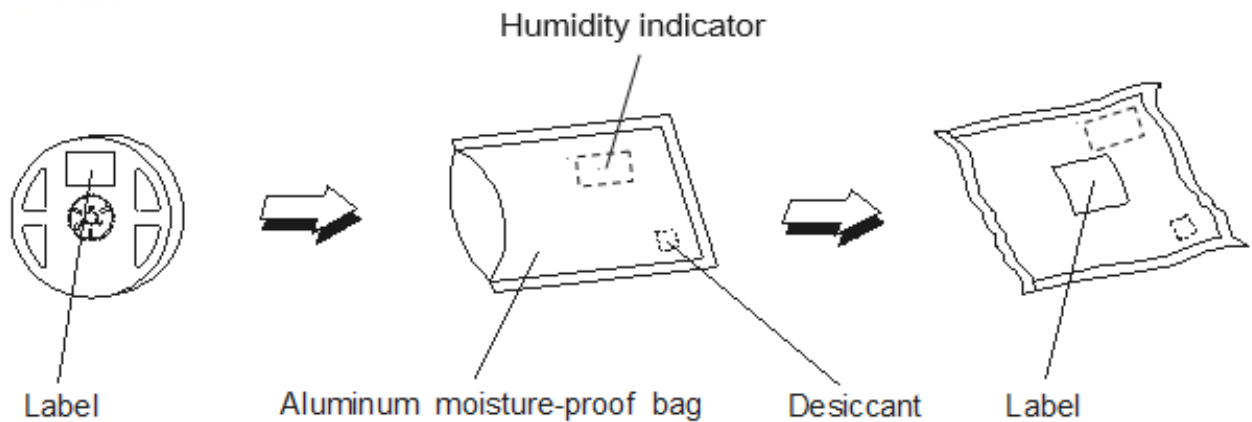
**Loaded Quantity 4000/3500/3000/2500/2000/1500/1000/500 pcs Per Reel**



**Notes:**

1. Tolerance unless mentioned is  $\pm 0.1\text{mm}$ ; Unit = mm

**Moisture Resistant Packing Process**



## Reliability Test Items and Conditions

The reliability of products shall be satisfied with items listed below.

Confidence level : 90%

LTPD : 10%

No.	Items	Test Condition	Test Hours/Cycles	Sample Size	Ac/Re
1	Resistance to Solder Heat	Temp. : 260°C /10sec.	3 Times.	8 PCS.	0/1
2	Temperature Cycle	-40°C~100°C / Dwell time 30min	200 Cycles	8 PCS.	0/1
3	High Temperature/Humidity Life	Ta=85°C,85%RH, I <sub>F</sub> =350mA	1000 Hrs.	8 PCS.	0/1
4	Low Temperature Life	Ta=-40°C, I <sub>F</sub> = 350 mA	1000 Hrs.	8 PCS.	0/1
5	High Temperature Life	Ta=60°C, I <sub>F</sub> =350mA	3000 Hrs.	8 PCS.	0/1
6	High Temperature Life	Ta=85°C, I <sub>F</sub> =350mA	3000 Hrs.	8 PCS.	0/1
7	Pulse	ON 30ms / OFF 2500ms	30000 CYCLES	8 PCS.	0/1
8	Thermal Shock	H : +100°C 20min ∩ 10 sec L : -10°C 20min	200 Cycles	8 PCS.	0/1
9	Power Temperature Cycle	H : +100°C 30min ∩ 5 min L : -40°C 30min I <sub>F</sub> = 65 mA	200 Cycles	8 PCS.	0/1

## Precautions for Use

### 1. Over-current-proof

Customer must apply resistors for protection; otherwise slight voltage shift will cause big current change (Burn out will happen).

### 2. Storage

2.1 Do not open moisture proof bag before the products are ready to use.

2.2 Before opening the package: The LEDs should be kept at 30°C or less and 90%RH or less.

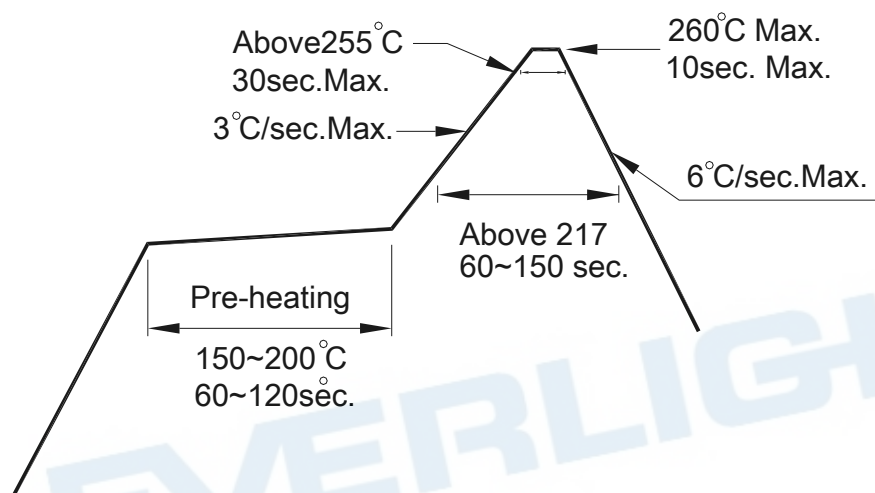
2.3 After opening the package: The LED's floor life is 168 Hrs under 30°C or less and 60% RH or less. If unused LEDs remain, it should be stored in moisture proof packages.

2.4 If the moisture absorbent material (silica gel) has faded away or the LEDs have exceeded the storage time, baking treatment should be performed using the following conditions.

Baking treatment: 60±5°C for 24 hours.

### 3. Soldering Condition

#### 3.1 Pb-free solder temperature profile



3.2 Reflow soldering should not be done more than two times.

3.3 When soldering, do not put stress on the LEDs during heating.

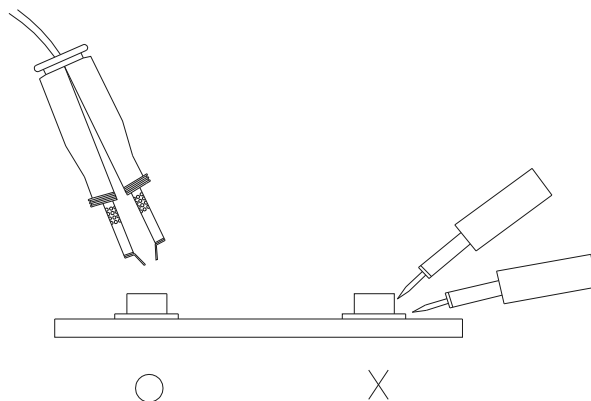
3.4 After soldering, do not warp the circuit board.

### 4. Soldering Iron

Each terminal is to go to the tip of soldering iron temperature less than 350°C for 3 seconds within once in less than the soldering iron capacity 25W. Leave two seconds and more intervals, and do soldering of each terminal. Be careful because the damage of the product is often started at the time of the hand solder.

### 5. Repairing

Repair should not be done after the LEDs have been soldered. When repairing is unavoidable, a double-head soldering iron should be used (as below figure). It should be confirmed beforehand whether the characteristics of the LEDs will or will not be damaged by repairing.



## DISCLAIMER

1. EVERLIGHT reserves the right(s) on the adjustment of product material mix for the specification.
2. The product meets EVERLIGHT published specification for a period of twelve (12) months from date of shipment.
3. The graphs shown in this datasheet are representing typical data only and do not show guaranteed values.
4. When using this product, please observe the absolute maximum ratings and the instructions for using outlined in these specification sheets. EVERLIGHT assumes no responsibility for any damage resulting from the use of the product which does not comply with the absolute maximum ratings and the instructions included in these specification sheets.
5. These specification sheets include materials protected under copyright of EVERLIGHT. Reproduction in any form is prohibited without obtaining EVERLIGHT's prior consent.
6. This product is not intended to be used for military, aircraft, automotive, medical,

EVERLIGHT