

### EL SIDE VIEW LED 57-11-SB0100L-AM



#### Features

- Package : PLCC 2 package
- Color : Sky Blue
- Typ. Luminance Intensity : 355 mcd @ 10mA
- Viewing angle : 120°
- ESD : 8KV
- MSL : 2
- Typ.color coordinates : (0.16,0.08)
- Qualified AEC-Q101
- Compliance with RoHS and REACH

#### Applications

- Automotive interior lighting.
- Switches.

# Contents

1. Characteristics .....	3
2. Absolute Maximum Ratings .....	4
3. Characteristics Graph .....	5
4. Binning Information .....	10
5. Part Number.....	15
6. Ordering Information .....	16
7. Mechanical Dimension.....	17
8. Recommended Soldering Pad.....	18
9. Reflow Soldering Profile.....	18
10. Packaging Information.....	19
11. Precaution for Use .....	21

EVERLIGHT

# 1. Characteristics

Parameter		Symbol	Min.	Typ.	Max.	Unit	Condition
Forward Current		$I_F$	2	10	20	mA	---
Luminous Intensity		$I_V$	140	355	560	mcd	$I_F=10\text{mA}$
Forward Voltage		$V_F$	2.75	2.90	3.75	V	$I_F=10\text{mA}$
Viewing Angle		$\phi$	---	120	---	deg	$I_F=10\text{mA}$
Color		CIE x	---	0.16	---		$I_F=10\text{mA}$
Color		CIE y	---	0.08	---	---	$I_F=10\text{mA}$
Thermal Resistance (Junction to Solder)	Real	$R_{th\ JS\ real}$	---	---	200	K/W	$I_F=10\text{mA}$
	Electrical	$R_{th\ JS\ el}$	---	---	125		

## Notes:

1. Luminous Flux measurement tolerance:  $\pm 8\%$ .
2. The data of Luminous Flux measured at thermal pad= $25^\circ\text{C}$
3. Forward voltage measurement tolerance:  $\pm 0.05\text{V}$
4. The  $V_F$  range shown in the table above indicates 99% output.
5. Tolerance of Chromaticity Coordinates x,y :  $\pm 0.005$

## 2. Absolute Maximum Ratings

Parameter	Symbol	Ratings	Unit
Power Dissipation	$P_d$	75	mW
Forward Current	$I_F$	20	mA
Surge Current ( $t \leq 10 \mu\text{s}$ ; $D=0.005$ ; $T_s=25 \text{ }^\circ\text{C}$ )	$I_{FM}$	300	mA
Reverse Voltage	$V_R$	Not designed for reverse operation	V
Junction Temperature	$T_J$	125	$^\circ\text{C}$
Operating Temperature	$T_{opr}$	-40 ~ +110	$^\circ\text{C}$
Storage Temperature	$T_{stg}$	-40 ~ +110	$^\circ\text{C}$
ESD Sensitivity ( $R=1.5\text{k}\Omega$ , $C=100\text{pF}$ )	$ESD_{HBM}$	8	kV
Soldering Temperature	Reflow	260 $^\circ\text{C}$ for 30sec	$^\circ\text{C}$

EVERLIGHT

### 3. Characteristics Graph

**Wavelength Characteristics Relative Spectral Distribution**  
 @  $T_s = 25^\circ\text{C}$ ,  $I_F = 10\text{mA}$

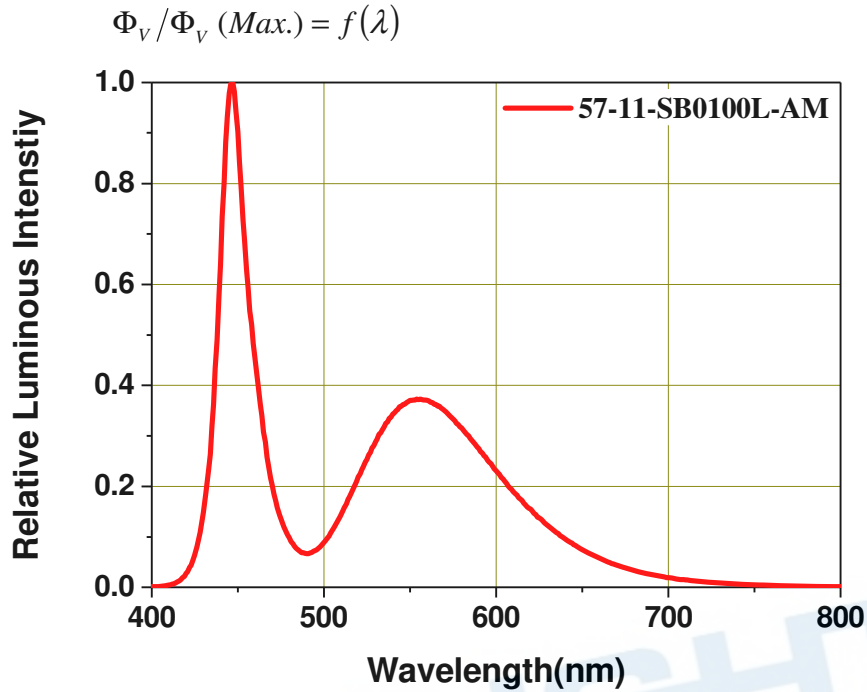

**Typical Diagram Characteristics of Radiation**

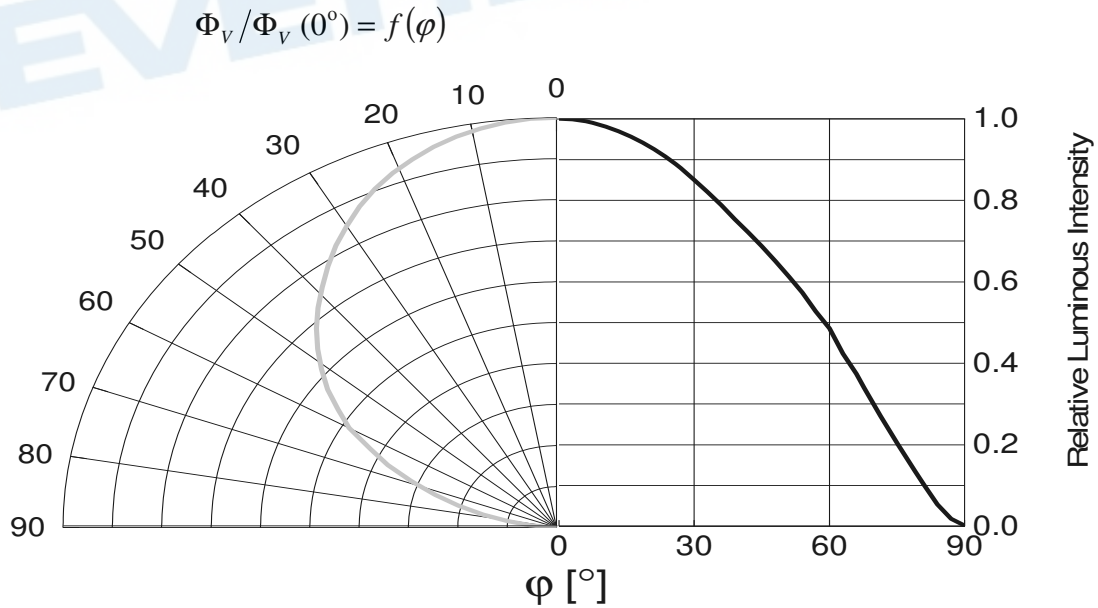

**Notes:**

1.  $\varphi$  is the off axis angle from lamp centerline where the luminous intensity is 1/2 of the peak value.
2. View angle tolerance is  $\pm 5^\circ$ .

### Forward Current vs. Forward Voltage @ Ts = 25°C

$$I_F = f(V_F)$$

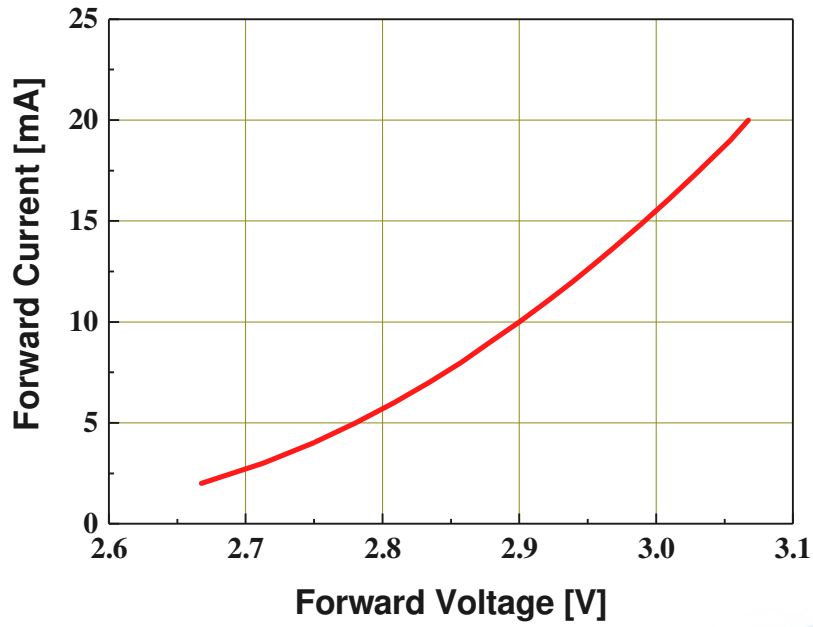

### Relative Luminous Intensity vs. Forward Current @ Ts = 25°C

$$\Phi_V / \Phi_V (10mA) = f(I_F)$$

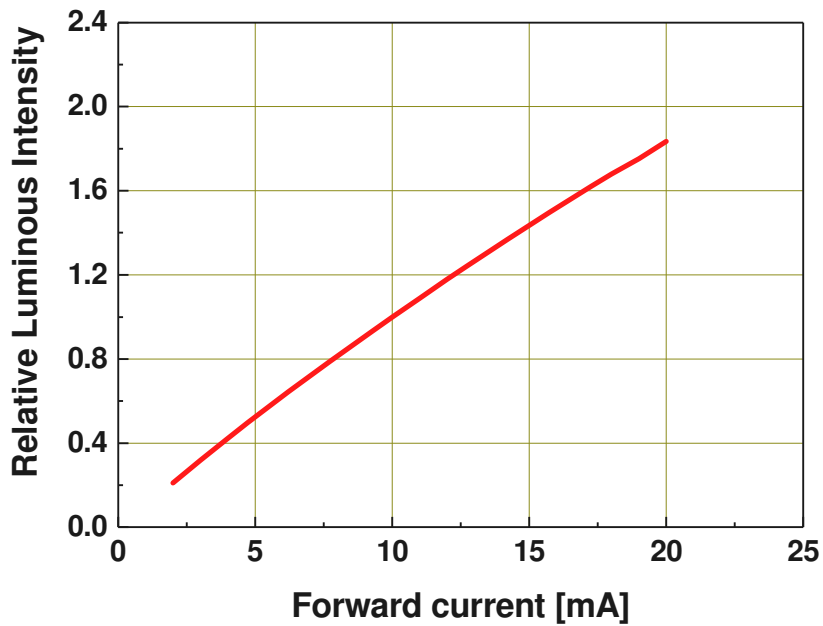

### Chromaticity Coordinates Shift vs. Forward Current

@  $T_s = 25^\circ\text{C}$

$$\Delta CIE\ x, \Delta CIE\ y = f(I_F)$$

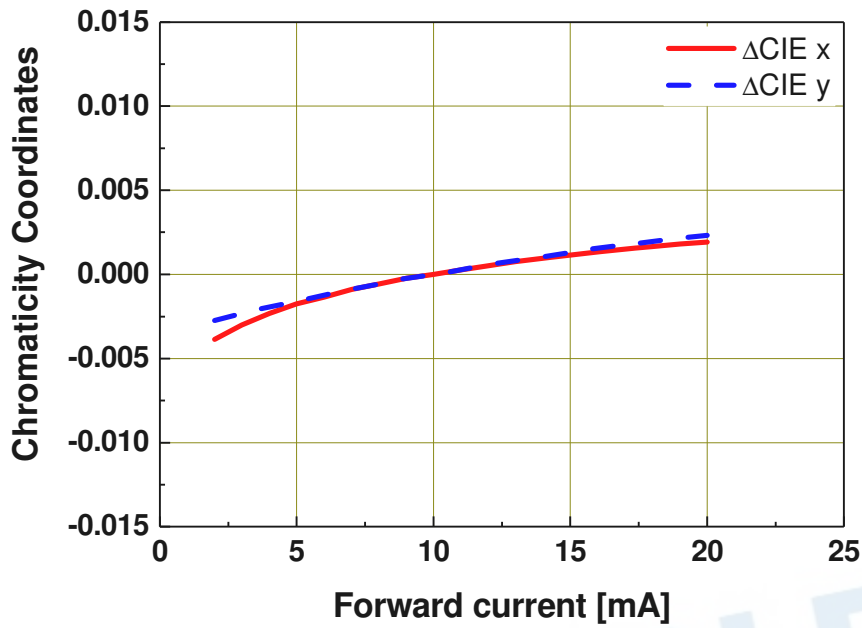

### Relative Forward Voltage vs. Junction Temperature

@  $I_F = 10\text{mA}$

$$\Delta V_F = V_F - V_F(25^\circ\text{C}) = f(T_j)$$

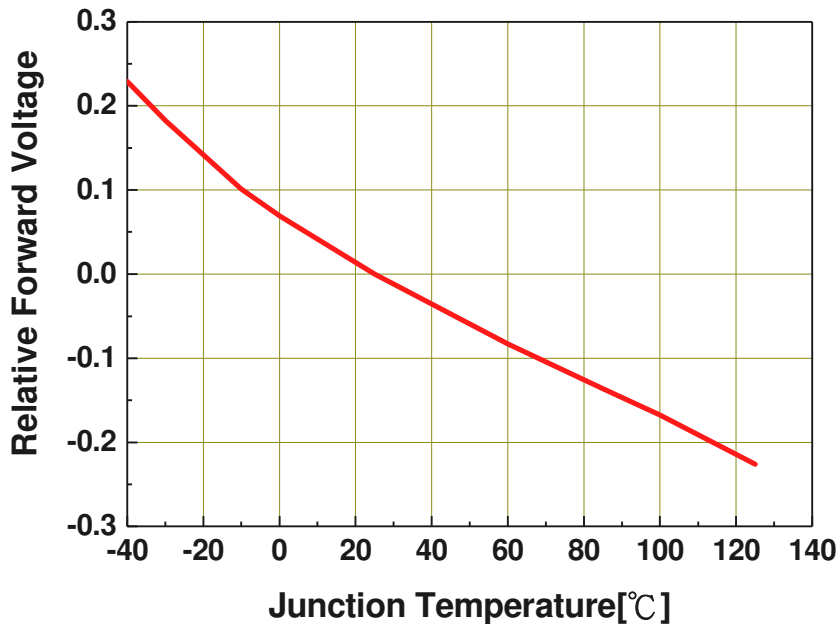

## Relative Luminous Intensity vs. Junction Temperature

@ I<sub>F</sub>=10mA

$$\Phi_v / \Phi_v(25^\circ C) = f(T_j)$$

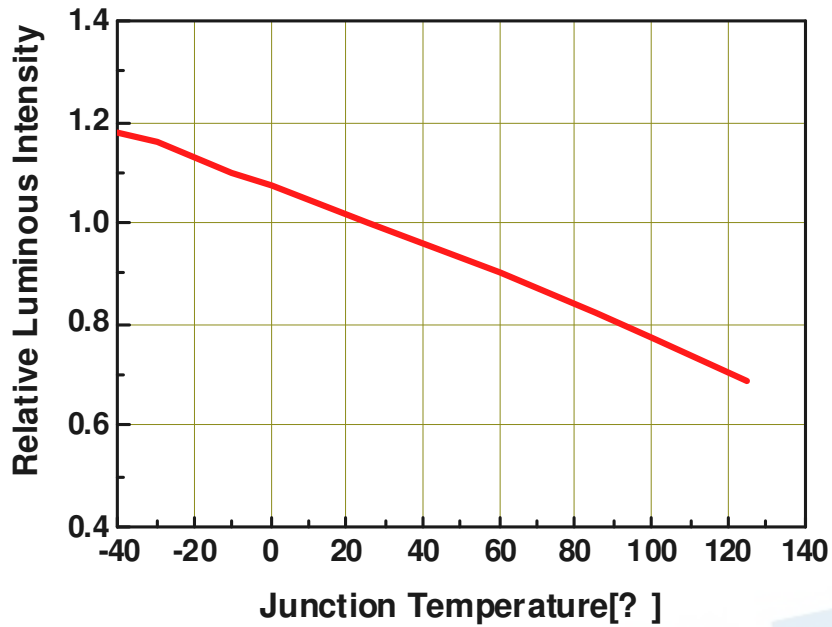

## Chromaticity Coordinates Shift vs. Junction Temperature

@ I<sub>F</sub>=10mA

$$\Delta CIE x, \Delta CIE y = f(T_j)$$

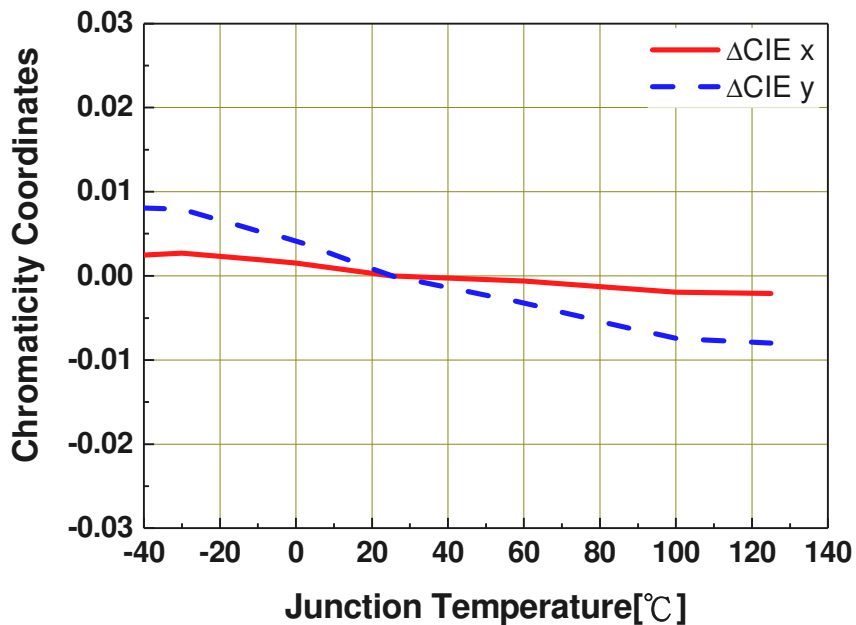

### Forward Current Derating Curve

$$I_F = f(T_S)$$

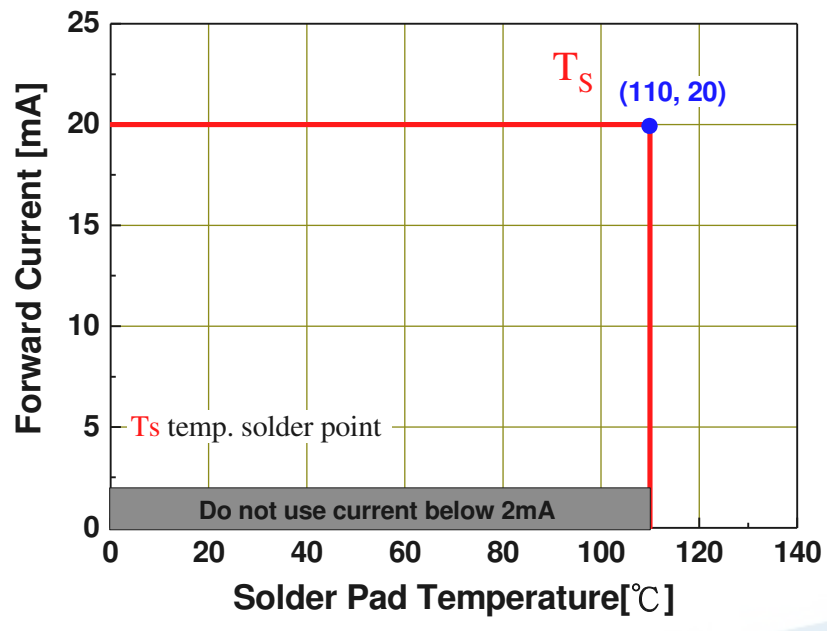

### Permissible Pulse Handling Capability

D=Duty cycle ,  $T_s = 25^\circ\text{C}$

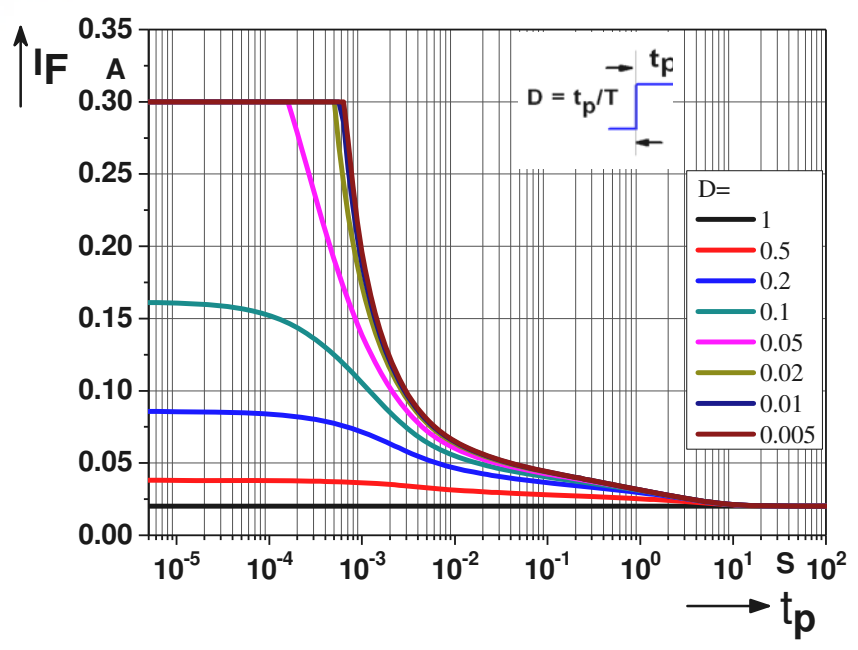

## 4. Binning Information

### Luminous Intensity Bins

Group Bin	Minimum Luminous Intensity (mcd)	Maximum Luminous Intensity (mcd)
L1	11.2	14
L2	14	18
M1	18	22.4
M2	22.4	28
N1	28	35.5
N2	35.5	45
P1	45	56
P2	56	71
Q1	71	90
Q2	90	112
R1	112	140
R2	140	180
S1	180	224
S2	224	280
T1	280	355
T2	355	450
U1	450	560
U2	560	710
V1	710	900
V2	900	1120
AA	1120	1400
AB	1400	1800
BA	1800	2240
BB	2240	2800
CA	2800	3550
CB	3550	4500
DA	4500	5600
DB	5600	7100
EA	7100	9000
EB	9000	11200
FA	11200	14000
FB	14000	18000
GA	18000	22400

**Notes:**

1. Luminous flux measurement tolerance:  $\pm 8\%$ .
2. Highlighted Black Box is possible output bins.

# Standard Sky Blue Color Bin Structure

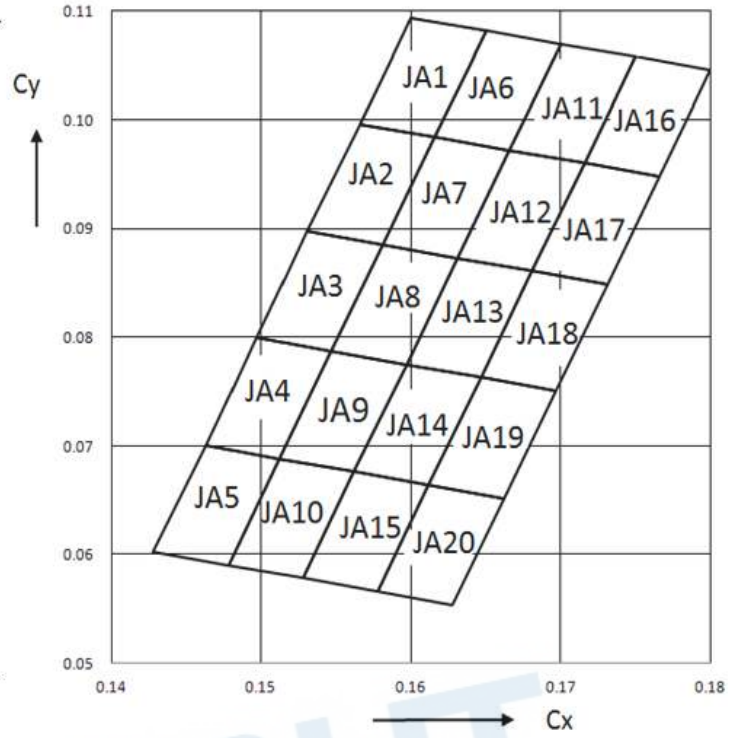
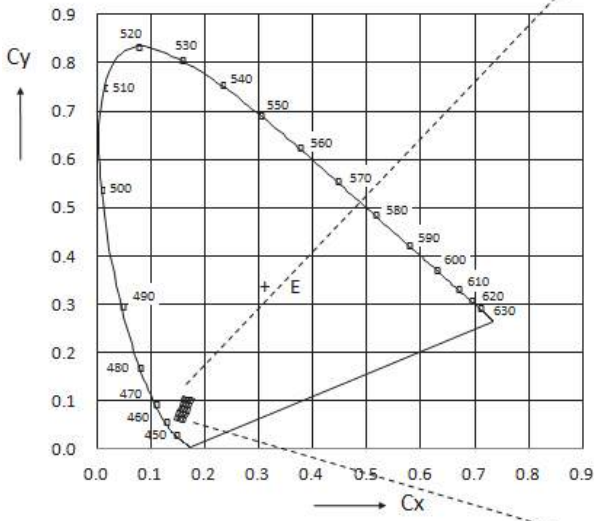

EVERLIGHT

### Sky Blue Bin Coordinates

Bin Code	CIE_x	CIE_y	Bin Code	CIE_x	CIE_y
JA1	0.1600	0.1094	JA11	0.1700	0.1070
	0.1650	0.1082		0.1750	0.1058
	0.1616	0.0984		0.1716	0.0960
	0.1566	0.0996		0.1666	0.0972
JA2	0.1566	0.0996	JA12	0.1666	0.0972
	0.1616	0.0984		0.1716	0.0960
	0.1581	0.0885		0.1681	0.0861
	0.1531	0.0897		0.1631	0.0873
JA3	0.1531	0.0897	JA13	0.1631	0.0873
	0.1581	0.0885		0.1681	0.0861
	0.1547	0.0787		0.1647	0.0763
	0.1497	0.0799		0.1597	0.0775
JA4	0.1497	0.0799	JA14	0.1597	0.0775
	0.1547	0.0787		0.1647	0.0763
	0.1512	0.0688		0.1612	0.0664
	0.1463	0.0700		0.1562	0.0676
JA5	0.1463	0.0700	JA15	0.1562	0.0676
	0.1512	0.0688		0.1612	0.0664
	0.1478	0.0590		0.1578	0.0566
	0.1428	0.0602		0.1528	0.0578
JA6	0.1650	0.1082	JA16	0.1750	0.1058
	0.1700	0.1070		0.1800	0.1046
	0.1666	0.0972		0.1766	0.0948
	0.1616	0.0984		0.1716	0.0960
JA7	0.1616	0.0984	JA17	0.1716	0.0960
	0.1666	0.0972		0.1766	0.0948
	0.1631	0.0873		0.1731	0.0849
	0.1581	0.0885		0.1681	0.0861

### Sky Blue Bin Coordinates

Bin Code	CIE_x	CIE_y	Bin Code	CIE_x	CIE_y
JA8	0.1581	0.0885	JA18	0.1681	0.0861
	0.1631	0.0873		0.1731	0.0849
	0.1597	0.0775		0.1697	0.0751
	0.1547	0.0787		0.1647	0.0763
JA9	0.1547	0.0787	JA19	0.1647	0.0763
	0.1597	0.0775		0.1697	0.0751
	0.1562	0.0676		0.1662	0.0652
	0.1512	0.0688		0.1612	0.0664
JA10	0.1512	0.0688	JA20	0.1612	0.0664
	0.1562	0.0676		0.1662	0.0652
	0.1528	0.0578		0.1628	0.0554
	0.1478	0.0590		0.1578	0.0566

EVERLIGHT

## Forward Voltage Bins

Bin code	Min Forward Voltage [V]	Max Forward Voltage [V]
1012	1.00	1.25
1215	1.25	1.50
1517	1.50	1.75
1720	1.75	2.00
2022	2.00	2.25
2225	2.25	2.50
2527	2.50	2.75
2730	2.75	3.00
3032	3.00	3.25
3235	3.25	3.50
3537	3.50	3.75
3740	3.75	4.00
4042	4.00	4.25
4245	4.25	4.50
4547	4.50	4.75
4750	4.75	5.00
5052	5.00	5.25
5255	5.25	5.50
5557	5.50	5.75
5760	5.75	6.00
6062	6.00	6.25
6265	6.25	6.50
6567	6.50	6.75
6770	6.75	7.00

### Notes:

1. Forward voltage measurement tolerance:  $\pm 0.05\text{V}$ .
2. Forward voltage bins are defined at  $I_F = 10\text{mA}$  operation.

## 5. Part Number

### 57-11-SB0100L-AM

Part number is designated with below details.

57-11 = Product family name.

SB= Color <sup>[1]</sup>

010 = Test current [mA]

0 = Lead Frame Type ( 0=Ag ; 1=Au ; 2=MLP)

L = Brightness Level (H=High ; M=Medium ; L=Low)

AM = Automotive application

Note

[1] Color :

Symbol	Description
C	Cool White
N	Neutral White
W	Warm White
PA	Phosphor Converted Amber
PR	Phosphor Converted Red
UB	Blue
IB	Ice Blue
SB	Sky Blue
UP	Purple
UG	Green
UY	Yellow
UYG	Brilliant Yellow Green
UPG	Pale Green
UA	Amber
UR	Red
SR	Super Red
RGB	RGB-Color
PYG	Phosphor Converted Yellow Green

## 6. Ordering Information

### 57-11-SB0100L-**ABCDEFGHIJKLMNO-PQ-AM**

Part Number of the 57-11	Order Code
57-11-SB0100L-AM	57-11-SB0100L-ABCDEFGHIJKLMNO-PQ-AM

Order code contains information with below details :

ABCDEF = min/max wavelength or CCT

GHJK = min./max. luminous flux in [lm] or luminous intensity in [mcd]

LMNO = min./max. forward voltage

PQ = internal code

AM = Automotive Application

EVERLIGHT

# 7. Mechanical Dimension

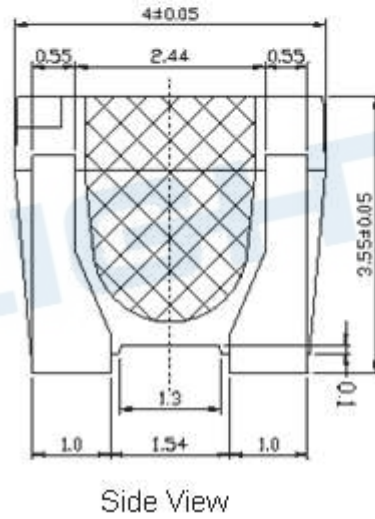
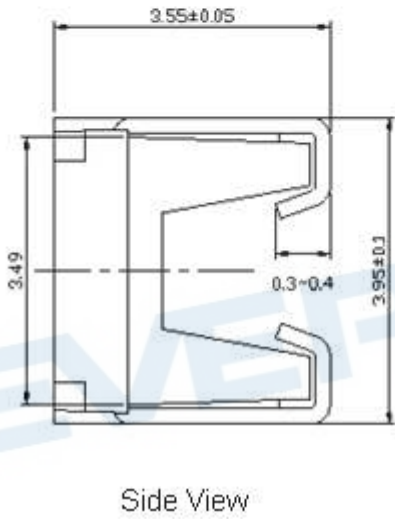
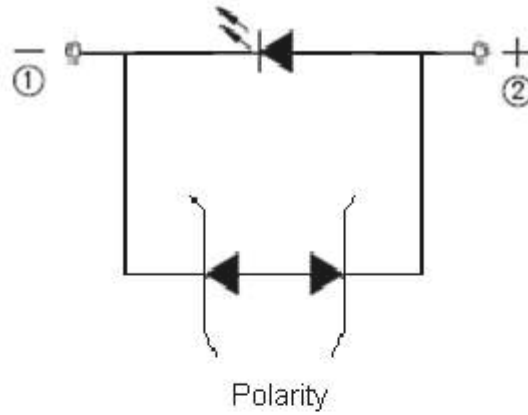
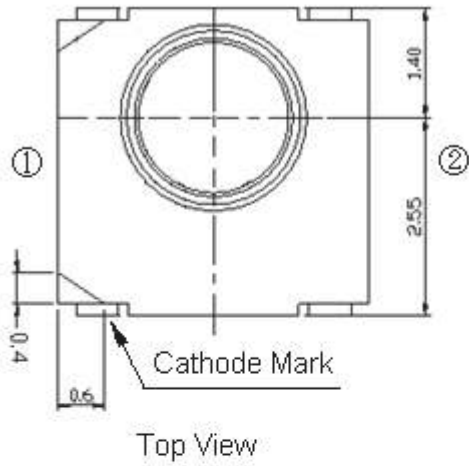

**Notes:**

- 1. Dimensions are in millimeters.
- 2. Tolerances unless mentioned are ± 0.1mm.

## 8. Recommended Soldering Pad

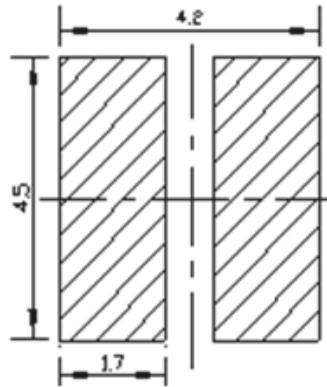

## 9. Reflow Soldering Profile

Soldering Condition (Reference: IPC/JEDEC J-STD-020D)

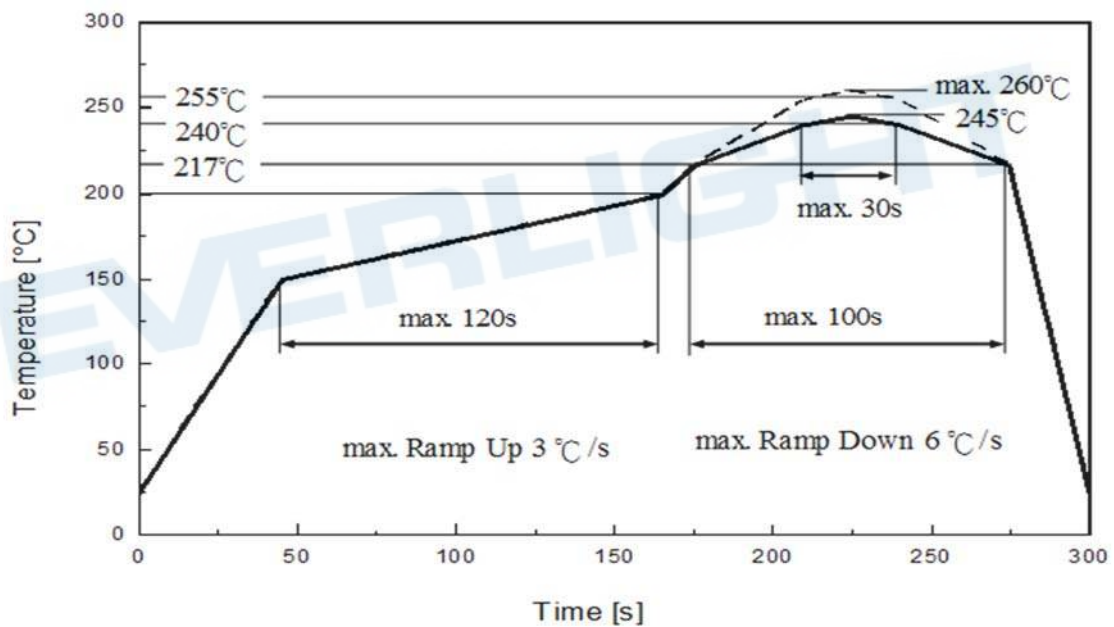

Profile Feature	Pb-Free Assembly	Unit
	Recommendation	
Ramp-up rate to preheat 25 °C to 150 °C	3	°C /sec
Time of soaking zone 150 °C to 200 °C	120	sec
Ramp-up rate to peak	3	°C /sec
Liquidus temperature	217	°C
Time above liquidus temperature	100	sec
Peak temperature (max.)	260	°C
Time within 5°C of the specified peak temperature	30	sec
Ramp-down Rate (max.)	6	°C /sec

# 10. Packaging Information

## • Product Labeling

RoHS Pb **EVERLIGHT**      5

CPN: XXXXXXXXXXXXXXXXXXXX  
  
 XXXXXXXXXXX-XXXXXXXXXX-XXXXXXXX-XXXXXXXX-XXXXXX  
 P/N: XXXXXXXXXXX  
  
 XXXXXXXXXXX-XXXXXXXXXX-XXXXXXXX-XXXXXXXX-XXXXXX  
 LOT NO: Y150716XXX-XXXXXXXXXX-XXXXXXXXXX  
  
 QTY: 0123456789    HUE: XXXXXXXXXXX  
  
 CAT: XXXXXXXXXXX    REF: XXXXXXXXXXX  
  
 REFERENCE: BTPYYMDDXXXXX  
  
 MSL-X                      MADE IN XXXXXX



- CPN : Customer's Product Number
- P/N : Everlight Part Number
- QTY : Packing Quantity
- CAT : Luminous Flux (Brightness) Bin
- HUE : Color Bin
- REF : Forward Voltage Bin
- LOT No : Lot Number

## • Packing: Loaded Quantity 500 pcs Per Reel

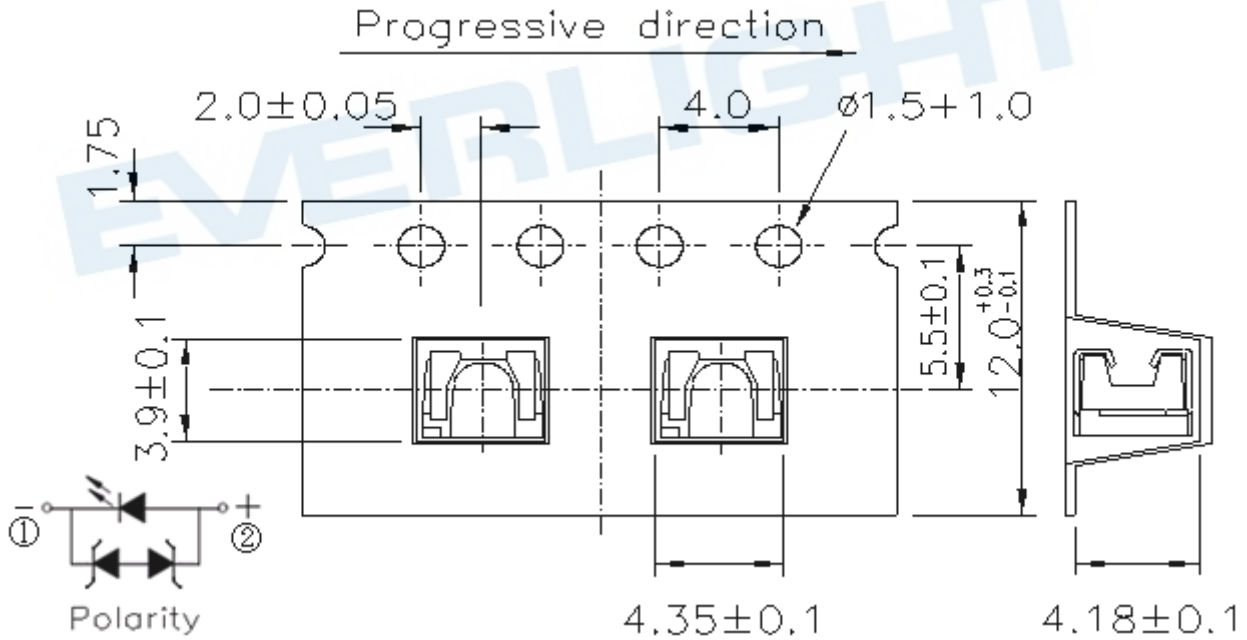

### Notes:

1. Dimensions are in millimeters.

• Reel Dimensions

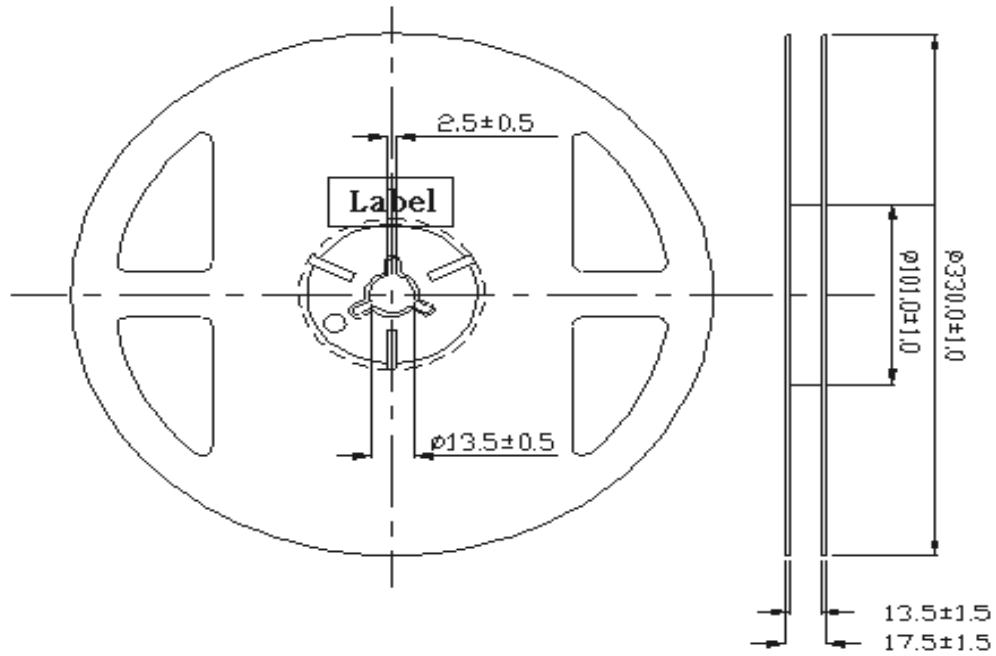

Notes:

1. Dimensions are in millimeters.

• Moisture Resistant Packing Process

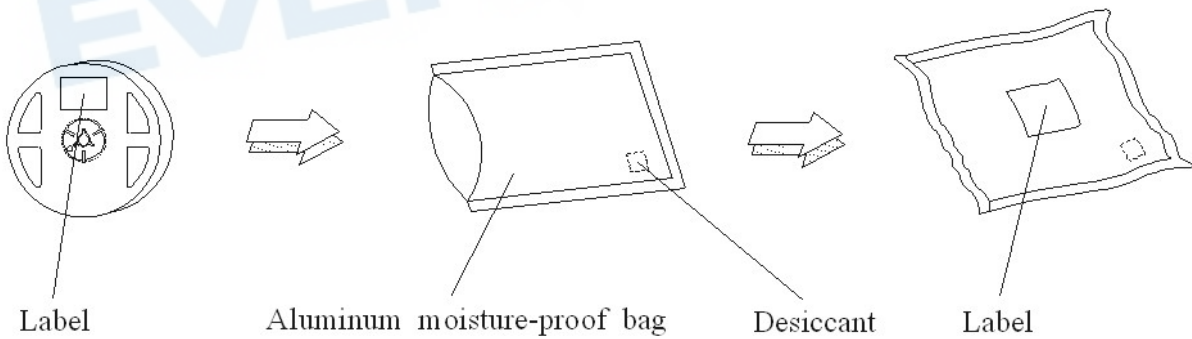

# 11. Precaution for Use

## 1. Over-current-proof

Customer must apply resistors for protection; otherwise slight voltage shift will cause big current change (burn out will happen).

## 2. Assemblies

Do not stack assemblies containing LEDs to prevent damage to the optical surface of LEDs. Forces applied to the optical surface may result in the surface being damaged.

## 3. Soldering Condition

3.1 When soldering, do not put stress on the LEDs during heating.

3.2 After soldering, do not warp the circuit board.

## 4. Soldering Iron

Each terminal is to go to the tip of soldering iron temperature less than 350°C for 3 seconds within once in less than the soldering iron capacity 25W. Leave two seconds and more intervals, and do soldering of each terminal. Be careful because the damage of the product is often started at the time of the hand solder.

## 5. Repairing

Repair should not be done after the LEDs have been soldered. When repairing is unavoidable, a double-head soldering iron should be used (as below figure). It should be confirmed beforehand whether the characteristics of the LEDs will or will not be damaged by repairing.

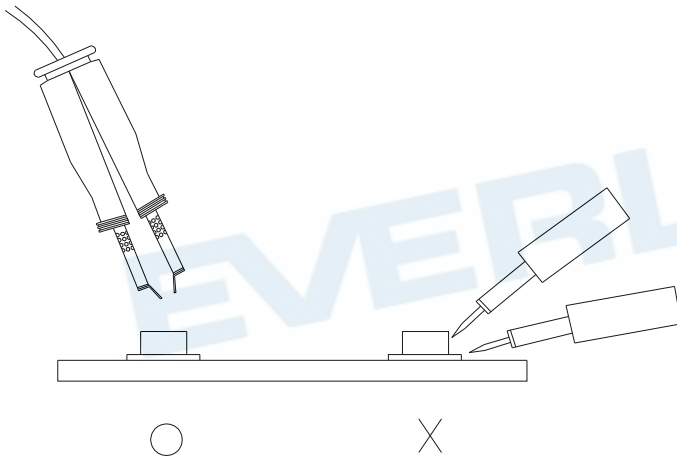

## Revision History

Current version : 08.May.2018

Issue No: DSE-0017521

Version: 4

Created by: Tini Lin

Rev.	Subjects (major change in previous version)	Modified date
1	Standard data sheet	2017/02/02
2	Add MSL, surge current, Permissible Pulse Handling Capability fig	2017/05/25
3	Modify the Characteristics Graph	2018/01/11
4	Package : PLCC 2 package	2018/05/08

EVERLIGHT