



SMD LED

Product Data Sheet

LTSA-G6SPVEKTU

Spec No.:
Created Date: 2017/02/20
Revision: 1.0

**SMD LED
LTSA-G6SPVEKTU**

SMD LED

LTSA-G6SPVEKTU

<u>Rev</u>	<u>Description</u>	<u>By</u>	<u>Date</u>
1	New datasheet	Ryan Chen	02/20/2017
Above data for PD and Customer tracking only			

CUTlomer Name:

CUTlomer Signature:

Print Name:

LiteON Sales Signature:

Print Name:

SMD LED LTSA-G6SPVEKTU

1. Description

SMD LEDs from Lite-On are available in miniature sizes and special configurations for automated PC board assembly and space-sensitive applications. These SMD LEDs are suitable for the accessory of engineering vehicles.

1.1 Features

- Meet ROHS
- Package in 12mm tape on 7" diameter reels
- Preconditioning: accelerate to JEDEC level 2
- Qualification is refer to AEC-Q101 Ver. D
- EIA STD package
- I.C. compatible
- Compatible with automatic placement equipment
- Compatible with infrared reflow solder process

1.2 Applications

- Automotive: accessory applications

2. Package Dimensions

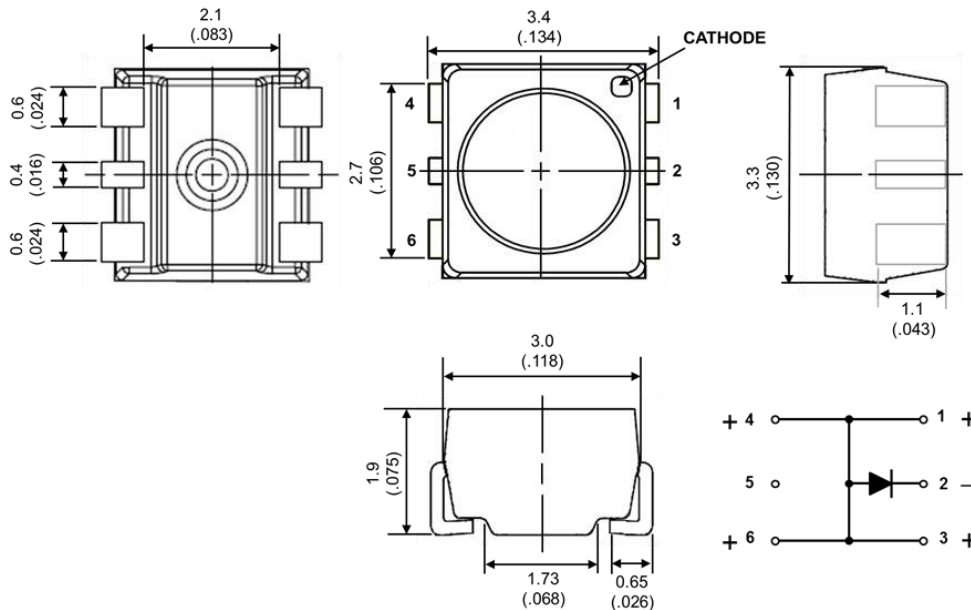

Part No.	Lens Color	Source Color
LTSA-G6SPVEKTU	Water Clear	AllnGaP Red

Notes:

1. All dimensions are in millimeters.
2. Tolerance is ± 0.2 mm (.008") unless otherwise noted.
3. ANODE lead frame is heat sink of LED.

SMD LED LTSA-G6SPVEKTU

3. Rating and Characteristics

3.1 Absolute Maximum Ratings at Ta=25°C

Parameter	LTSA-G6SPVEKTU	Unit
Power Dissipation	530	mW
Peak Forward Current (1/10 Duty Cycle, 0.1ms Pulse Width)	400	mA
DC Forward Current Range	5...200	mA
Operating Temperature Range	-40°C to +110°C	
Storage Temperature Range	-40°C to + 110°C	
Infrared Soldering Condition	260 °C For 10 Seconds	

Note : DC Forward minimum current is 5mA, Maximum is 200mA (Fig 3&5)

3.2 Thermal Characteristics

Parameter	Symbol	TYP.	MAX.	Unit
Thermal Resistance (Junction – Ambient) ^{Note}	Rth JA	50	-	°C /W
Thermal Resistance (Junction – Solder Point) ^{Note}	Rth JS	30	-	°C /W
Junction Temperature	T _J	-	125	°C

Note: Rth JA Measurement Condition

Substrate: FR4 (t=1.6mm) / Pattern Size: 16mm²

**SMD LED
LTSA-G6SPVEKTU**

3.3 Suggest IR Reflow Condition for Pb Free Process:

IR-Reflow Soldering Profile for lead free soldering (Acc. to J-STD-020)

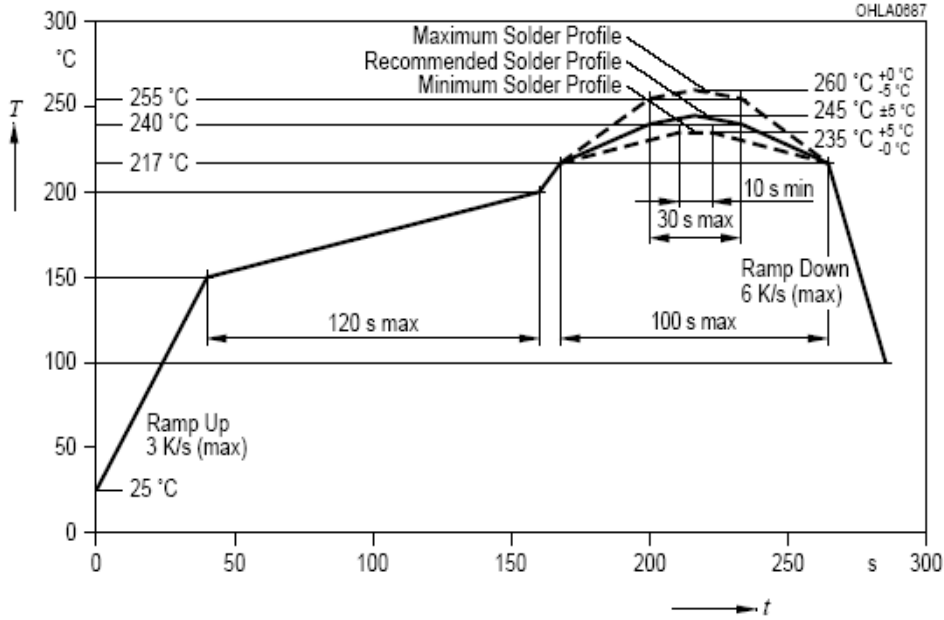

SMD LED LTSA-G6SPVEKTU

3.4 Electrical / Optical Characteristics at Ta=25°C

Parameter	Symbol	Part No. LTSA-	Min.	Typ.	Max.	Unit	Test Condition
Luminous Intensity	IV	G6SPVEKTU	4.5	-	11.2	cd	IF = 140mA Note 1
Viewing Angle	2θ _{1/2}	G6SPVEKTU	-	120	-	deg	Note 2 (Fig.2)
Peak Emission Wavelength	λ _P	G6SPVEKTU	-	631	-	nm	Measurement @Peak (Fig.1)
Dominant Wavelength	λ _d	G6SPVEKTU	620	-	629	nm	IF = 140mA Note 3
Spectral Line Half-Width	Δλ	G6SPVEKTU	-	18	-	nm	
Forward Voltage	VF	G6SPVEKTU	1.90	-	2.65	V	IF = 140mA Note 4
Reverse Current	IR	G6SPVEKTU	-		10	μA	VR =12V Note 5

Notes:

- Luminous intensity is measured with a light sensor and filter combination that approximates the CIE eye-response curve
- θ_{1/2} is the off-axis angle at which the luminous intensity is half the axial luminous intensity.
- The dominant wavelength, λ_d is derived from the CIE chromaticity diagram and represents the single wavelength which defines the color of the device. Dominant Wavelength Tolerance is +/- 1nm.
- Forward Voltage Tolerance is +/- 0.1 volt.
- Reverse voltage (VR) condition is applied to IR test only. The device is not designed for reverse operation

SMD LED LTSA-G6SPVEKTU

4. Bin Rank

Batch Description on Label: Vf / Iv/Wd (Ex. F/EA/1)

■ Vf Rank

Forward Voltage (Vf)		Unit : V @140mA	
Bin Code	Min.	Max.	
C	1.90	2.05	
D	2.05	2.20	
E	2.20	2.35	
F	2.35	2.50	
G	2.50	2.65	

Tolerance on each Voltage bin is +/-0.1V

■ IV Rank

Luminous Intensity (Iv)		Unit : cd @140mA	
Bin Code	Min.	Max.	
DA	4.5	5.6	
EA	7.1	9.0	
EB	9.0	11.2	

Tolerance on each Intensity bin is +/-11%

■ Wd Rank

Dominant Wavelength (Wd)		Unit : nm @140mA	
Bin Code	Min.	Max.	
1	620	629	

Tolerance on each Wavelength bin is +/-1nm

**SMD LED
LTSA-G6SPVEKTU**

5. Typical Electrical / Optical Characteristics Curves.

25°C Ambient Temperature Unless Special Noted

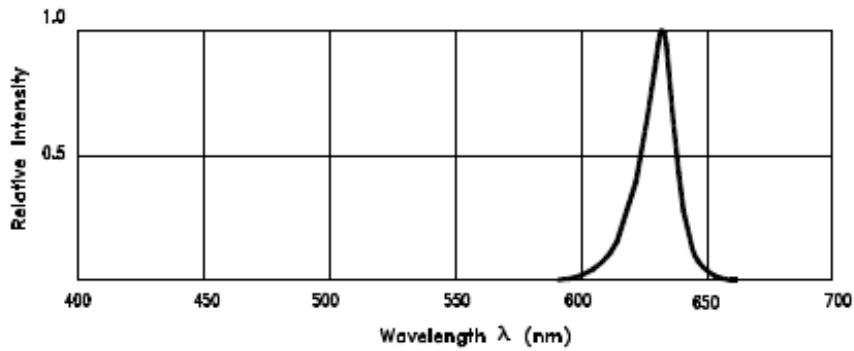

Fig.1 RELATIVE INTENSITY VS. WAVELENGTH

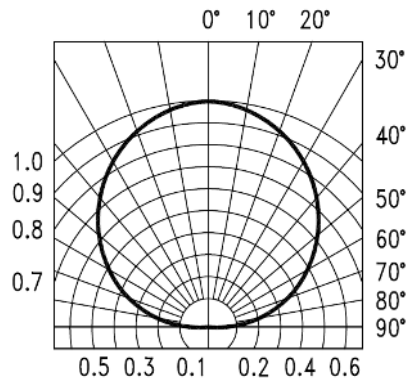

Fig. 2 SPATIAL DISTRIBUTION

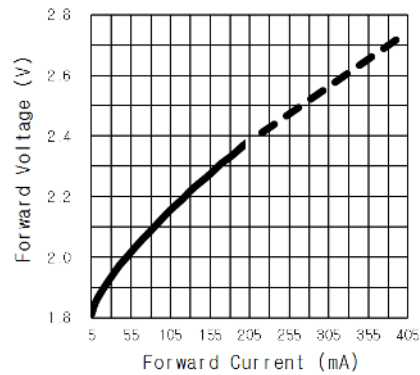

Fig. 3 FORWARD VOLTAGE V.S. FORWARD CURRENT

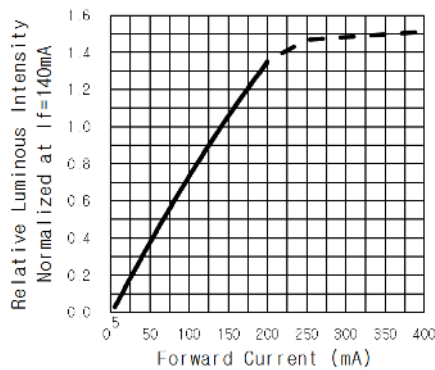

Fig. 4 RELATIVE LUMINOUS INTENSITY V.S. FORWARD CURRENT

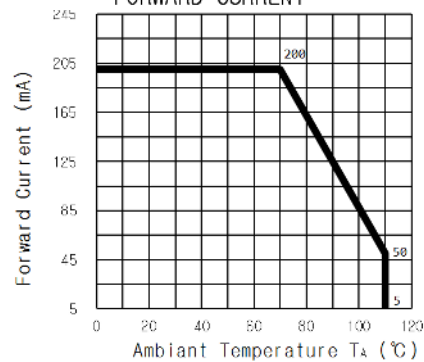

Fig.5 FORWARD CURRENT DERATING CURVE

SMD LED LTSA-G6SPVEKTU

6. User Guide

6.1 Cleaning

Do not use unspecified chemical liquid to clean LED they could harm the package. If cleaning is necessary, immerse the LED in ethyl alcohol or isopropyl alcohol at normal temperature for less one minute.

6.2 Recommend Printed Circuit Board Attachment Pad

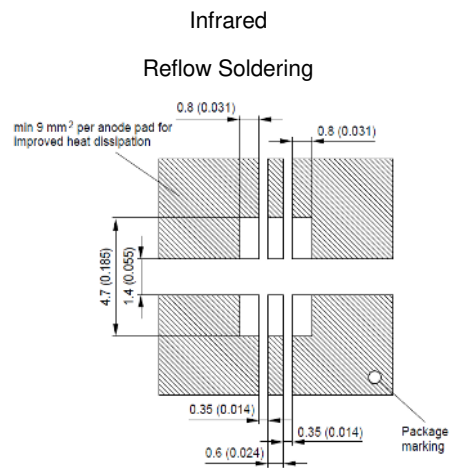

6.3 Package Dimensions of Tape And Reel

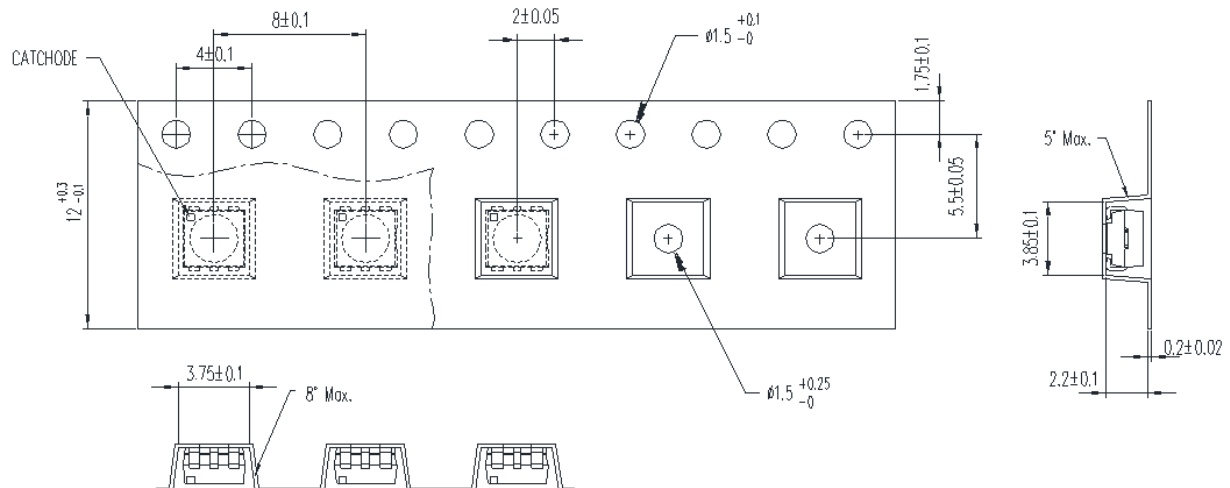

Note:

SMD LED LTSA-G6SPVEKTU

1. All dimensions are in millimeters (inches).

6.4 Package Dimensions of Reel

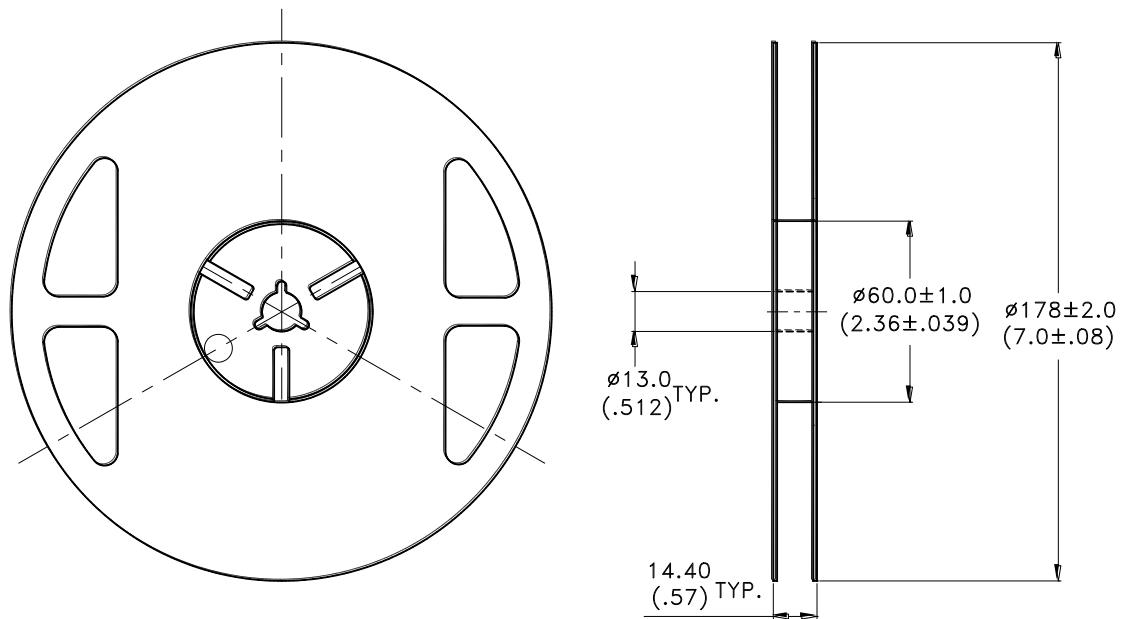

Notes:

1. Empty component pockets sealed with top cover tape.
2. 7 inch reel 1000 pieces per reel.
3. Minimum packing quantity is 500 pieces for remainders.
4. The maximum number of consecutive missing lamps is two.
5. In accordance with ANSI/EIA 481 specifications.

SMD LED LTSA-G6SPVEKTU

7. Cautions

7.1 Application

The LEDs described here are intended to be used for ordinary electronic equipment (such as office equipment, communication equipment and household applications). Consult Liteon's Sales in advance for information on applications in which exceptional reliability is required, particularly when the failure or malfunction of the LEDs may directly jeopardize life or health (such as in aviation, transportation, traffic control equipment, medical and life support systems and safety devices).

7.2 Storage

This product is qualified as Moisture sensitive Level 2 per JEDEC J-STD-020 Precaution when handling this moisture sensitive product is important to ensure the reliability of the product.

The package is sealed:

The LEDs should be stored at 30°C or less and 70%RH or less. And the LEDs are limited to use within one year, while the LEDs is packed in moisture-proof package with the desiccants inside.

The package is opened:

The storage ambient for the LEDs should not exceed 30°C temperature and 60% relative humidity.

It is recommended that LEDs out of their original packaging are IR-reflowed within one year.

For extended storage out of their original packaging, it is recommended that the LEDs be stored in a sealed container with appropriate desiccant, or in a desiccators with nitrogen ambient.

LEDs stored out of their original packaging for more than one year should be baked at about 60 °C for at least 48 hours before solder assembly.

7.3 Cleaning

Use alcohol-based cleaning solvents such as isopropyl alcohol to clean the LED if necessary.

7.4 Soldering

Recommended soldering conditions:

Reflow soldering		Soldering iron	
Pre-heat	150~200°C	Temperature	300°C Max.
Pre-heat time	120 sec. Max.	Soldering time	3 sec. Max.
Peak temperature	260°C Max.		(one time only)
Soldering time	10 sec. Max.(Max. two times)		

Notes:

Because different board designs use different number and types of devices, solder pastes, reflow ovens, and circuit boards, no single temperature profile works for all possible combinations.

However, you can successfully mount your packages to the PCB by following the proper guidelines and PCB-specific characterization.

LITE-ON Runs both component-level verification using in-house **KYRAMX98** reflow chambers and board-level assembly. The results of this testing are verified through post-reflow reliability testing. Profiles used at LITE-ON are based on JEDEC standards to ensure that all packages can be successfully and reliably surface mounted.

Figure on page3 shows a sample temperature profile compliant to JEDEC standards. You can use this example as a generic target to set up your reflow process. You should adhere to the JEDEC profile limits as well as specifications and recommendations from the solder paste manufacturer to avoid damaging the device and create a reliable solder joint.

SMD LED LTSA-G6SPVEKTU

7.5 Drive Method

A LED is a current-operated device. In order to ensure intensity uniformity on multiple LEDs connected in parallel in an application, it is recommended that a current limiting resistor be incorporated in the drive circuit, in series with each LED as shown in Circuit A below.

Circuit model A

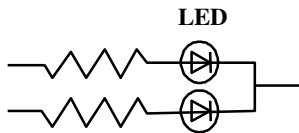

Circuit model B

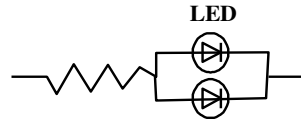

(A) Recommended circuit.

(B) The brightness of each LED might appear different due to the differences in the I-V characteristics of those LEDs.

7.6 ESD (Electrostatic Discharge)

Static Electricity or power surge will damage the LED.

Suggestions to prevent ESD damage:

- Use of a conductive wrist band or anti-electrostatic glove when handling these LEDs.
- All devices, equipment, and machinery mUTI be properly grounded.
- Work tables, storage racks, etc. should be properly grounded.
- Use ion blower to neutralize the static charge which might have built up on surface of the LED's plastic lens as a result of friction between LEDs during storage and handling.

ESD-damaged LEDs will exhibit abnormal characteristics such as high reverse leakage current, low forward voltage, or "no lightup" at low currents.

To verify for ESD damage, check for "lightup" and V_f of the suspect LEDs at low currents.

The V_f of "good" LEDs should be $>2.0V@0.1mA$ for InGaN product and $>1.4V@0.1mA$ for AlInGaP product.

SMD LED LTSA-G6SPVEKTU

8. Reliability Test

8.1 Test Item/Condition (Based on AEC-Q101 Ver. D):

No.	Test item	Test condition	Sample size Per Lot	Reference standard
1	Pre-conditioning	MSL 2 125°C, 24 hrs baking Moisture Soak 85°C/60% 168 hrs Interval: 15mins ~ 4 hours to do IR-Reflow	462	JESD22 A-113
5b+	High Temperature Forward Bias (HTFB)	Ta=70 ± 2°C IF: 200 mA 1000 hrs	77	JESD22 A-108
5b	High Temperature Forward Bias (HTFB)	Ta=110 ± 2°C IF: 50mA 1000 hrs	77	JESD22 A-108
7	Temperature Cycle (TC)	-40°C(+0, -10) to 100°C(+15,-0) 10 min 10 min 10 min 1000 cycles	77	JESD22 A-104 Appendix 6
9a	High Temperature High Humidity Bias (HTHHB)	Ta=85 ± 2°C, 85 ± 5% RH IF: 145mA 1000 hrs	77	JESD22 A-101
10alt	Power and Temperature Cycle (PTC)	-40°C (+0, -10) to 85°C (+10,-0) 10 min 20 min 10 min IF: 145mA 1 cycle: 2 min. on / 2 min. off 15000 cycles (1000 hrs)	77	JESD22 A-105
11	ESD Characterization	HBM 2000V,	30	JESD22-A114-F
20	Resistance to Solder Heat	Tsld=260°C, 10sec. 3times	30	JESD22A-111
21	Solderability	Tsld = 235± 5°C, 5sec, Leas-free Solder	10	J-STD-002 JESD22B102

SMD LED LTSA-G6SPVEKTU

9. Others

The appearance and specifications of the product may be modified for improvement without prior notice.

10. Suggested Checking List

Training and Certification

1. Everyone working in a static-safe area is ESD-certified?
2. Training records kept and re-certification dates monitored?

Static-Safe Workstation & Work Areas

1. Static-safe workstation or work-areas have ESD signs?
2. All surfaces and objects at all static-safe workstation and within 1 ft measure less than 100V?
3. All ionizer activated, positioned towards the units?
4. Each work surface mats grounding is good?

Personnel Grounding

1. Every person (including visitors) handling ESD sensitive (ESDS) items wears wrist strap, heel strap or conductive shoes with conductive flooring?
2. If conductive footwear used, conductive flooring also present where operator stand or walk?
3. Garments, hairs or anything closer than 1 ft to ESD items measure less than 100V*?
4. Every wrist strap or heel strap/conductive shoes checked daily and result recorded for all DLs?
5. All wrist strap or heel strap checkers calibration up to date?

Note: *50V for InGaN LED.

Device Handling

1. Every ESDS items identified by EIA-471 labels on item or packaging?
2. All ESDS items completely inside properly closed static-shielding containers when not at static-safe workstation?
3. No static charge generators (e.g. plastics) inside shielding containers with ESDS items?
4. All flexible conductive and dissipative package materials inspected before reuse or recycles?

Others

1. Audit result reported to entity ESD control coordinator?
2. Corrective action from previous audits completed?
3. Are audit records complete and on file?