



Specific Lighting Product Data Sheet

LTPL-C16FUVM365

Spec No.: DS23-2016-0117

Effective Date: 12/14/2016

Revision: -

LITE-ON DCC

RELEASE

BNS-OD-FC001/A4

1. Description

The LTPL-C16 series is a revolutionary, energy efficient and ultra-compact new light source, combining the lifetime and reliability advantages of Light Emitting Diodes with the brightness of conventional lighting. It gives you total design freedom and unmatched brightness, creating a new opportunities for solid state lighting to displace conventional lighting technologies.

1.1 Features

- Compatible with automatic placement equipment.
- Compatible with infrared and vapor phase reflow solder process.
- EIA STD package.
- I.C. compatible.
- Meet green product and Pb-free(According to RoHS)

1.2 Application

- UV curing , UV marking , UV gluing
- UV drying of printing inks...etc.

2. Outline Dimensions

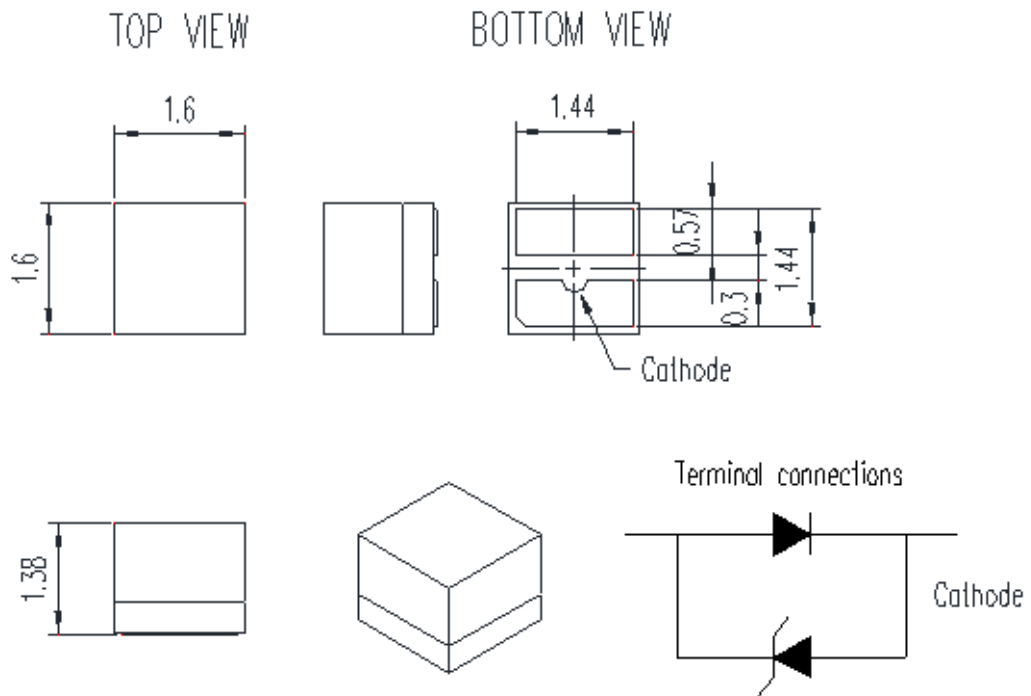

Notes :

1. All dimensions are in millimeters.
2. Tolerance is ± 0.1 mm (.004") unless otherwise noted.

3. Absolute Maximum Ratings at Ta=25°C

Parameter	Symbol	Rating	Unit
Power Dissipation	P_o	160	mW
DC Forward current	I_f	40	mA
Reverse Voltage ^{*6}	V_r	5	V
Operating Temperature Range	T_{opr}	-40 ~ +85	°C
Storage Temperature Range	T_{stg}	-40 ~ +100	°C
Junction Temperature	T_j	90	°C

4. Electro-Optical Characteristics at Ta=25°C

Parameter	Symbol	Value			Unit	Test Condition
		MIN.	TYP.	MAX.		
Radiant flux	Φ_e	14	19	26	mW	$I_f = 20\text{mA}$
Viewing Angle	$2\theta_{1/2}$	--	135	--	Deg	
Peak Wavelength	W_p	362.5	367	370		$I_f = 20\text{mA}$
Forward Voltage	V_f	2.8	3.5	4.0	V	$I_f = 20\text{mA}$
Reverse Voltage	V_r	--	--	1.2	V	$I_r = 10\mu\text{A}$ Note 6
Thermal Resistance	$R_{th\text{-}j\text{-}s}$		53		°C/W	

Notes:

1. Caution in ESD:

Static Electricity and surge will damages the LED. It is recommended to use a wrist band or anti-electrostatic glove when handling the LED. All devices, equipment and machinery must be properly grounded.

2. CAS140B is the test standard for the Radiant flux (Φ_e) & Peak wavelength (W_p).

3. Radiant flux (Φ_e) measurement tolerance: $\pm 10\%$

4. Forward voltage (V_f) measurement tolerance: $\pm 0.1\text{V}$

5. Peak Wavelength (W_p) measurement tolerance: $\pm 3\text{nm}$

6. Reverse Current (I_r) condition is applied for Reverse Voltage (V_r) test only (For test Zener function). The device is not designed for reverse operation. Operating the LED under reverse current condition long time might result in damage or failure of the component.

5. Bin Code List

<i>V_f</i> : Forward Voltage Spec. Table		
<i>V_f</i> Bin	<i>V_f</i> (V) @ <i>I_f</i> = 20mA	
	Min.	Max.
V1	2.8	3.2
V2	3.2	3.6
V3	3.6	4.0

Forward Voltage measurement tolerance : ±0.1V

Φ_e : Radiant Flux Spec. Table		
Φ_e Bin	Φ_e (mW) @ <i>I_f</i> = 20mA	
	Min.	Max.
R3	14	16
R4	16	18
R5	18	20
R6	20	22
R7	22	24
R8	24	26

Radiant Flux measurement tolerance: ±10%

<i>W_p</i> : Peak Wavelength Spec table		
<i>W_p</i> Bin	<i>W_p</i> (nm) @ <i>I_f</i> = 20mA	
	Min.	Max.
P3M2	362.5	365.0
P3N1	365.0	367.5
P3N2	367.5	370.0

Peak Wavelength Tolerance: +/- 3nm

Notes:

1. Bin classification code is marked on each packing bag.

6. Typical Electrical / Optical Characteristics Curves

(25°C Ambient Temperature Unless Otherwise Noted)

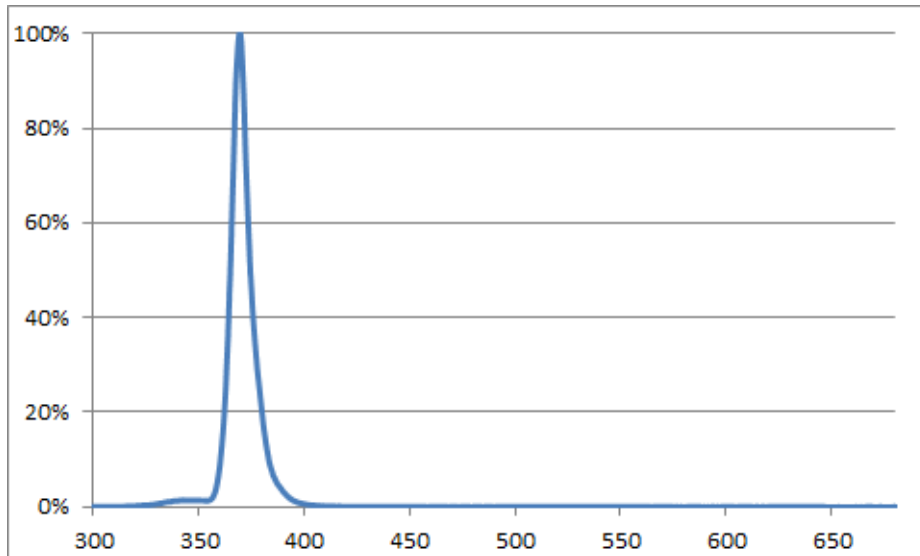

Fig 1. Relative Spectrum of Emission

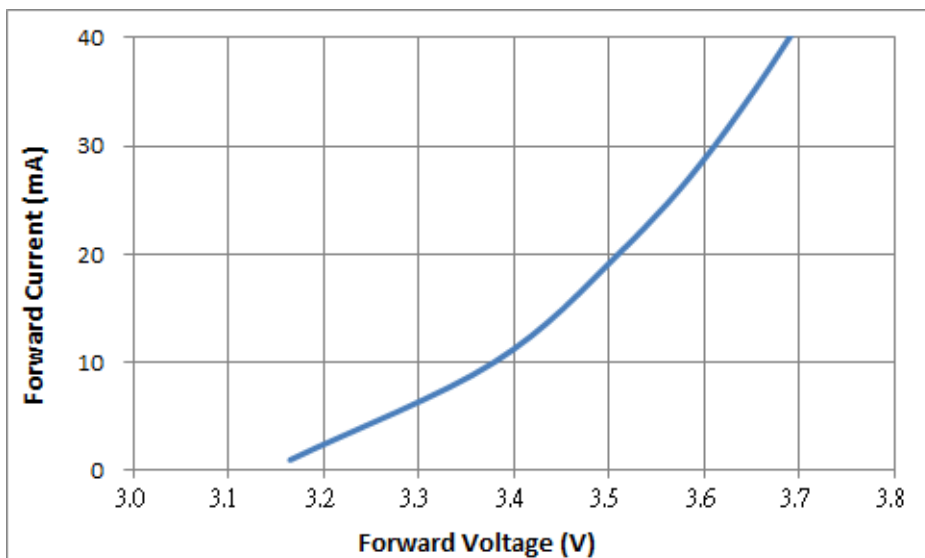

Fig.2 Relative Radiant Flux vs. Forward Current

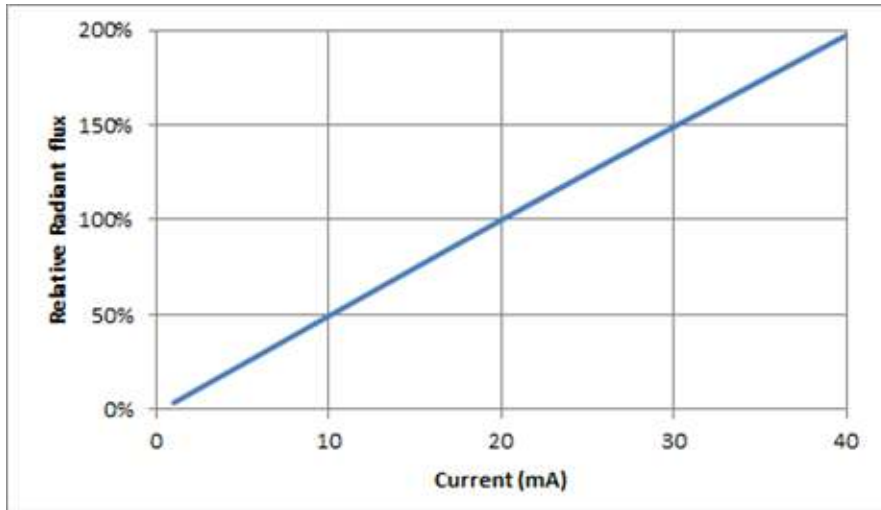

Fig. 3 Forward Current vs. Forward Voltage

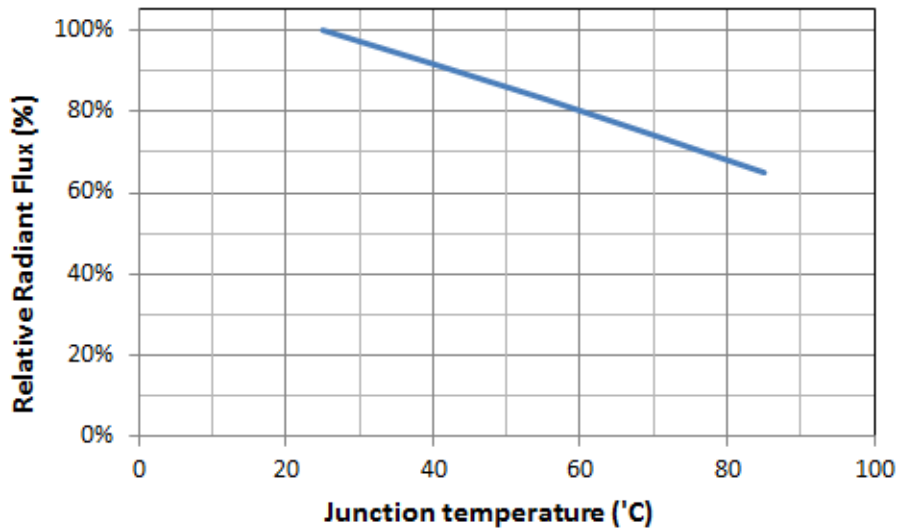
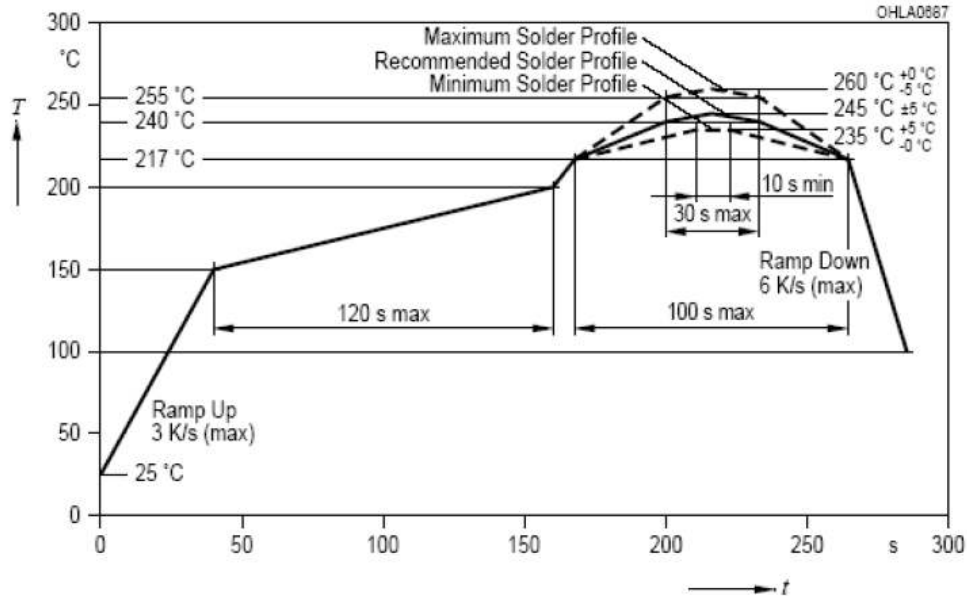

Fig.4 Relative Radiant Flux vs. Junction Temperature

7. User Guide

Suggest IR Reflow Condition For Pb Free Process



Notes:

1. All temperatures refer to topside of the package, measured on the package body surface.
2. The soldering profile could be further referred to different soldering grease material characteristic. The grease vendor will provide this information.
3. A rapid-rate process is not recommended for the LEDs cooling down from the peak temperature.
4. Although the recommended reflow conditions are specified above, the reflow or hand soldering condition at the lowest possible temperature is desirable for the LEDs.
5. LiteOn cannot make a guarantee on the LEDs which have been already assembled using the dip soldering method.

**Specific Lighting
LTPL-C16FUV365**

Cleaning

Do not use unspecified chemical liquid to clean LED, they could harm the package.

If cleaning is necessary, immerse the LED in ethyl alcohol or isopropyl alcohol at normal temperature for less than one minute.

Recommend Printed Circuit Board Attachment Pad

Infrared / vapor phase Reflow Soldering

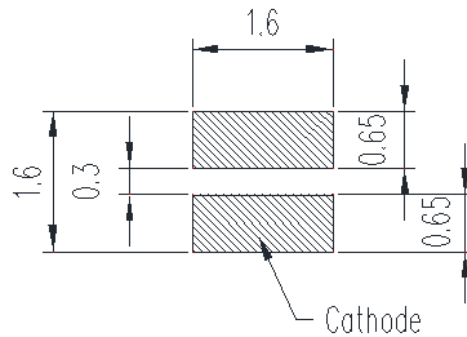

Package Dimensions of Tape

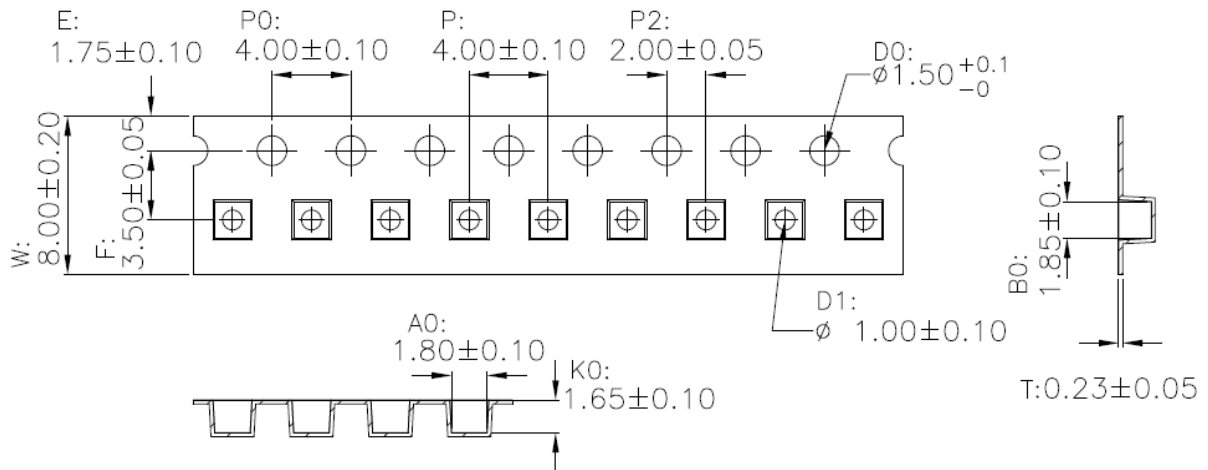

Note: All dimensions are in mm

Package Dimensions of Reel

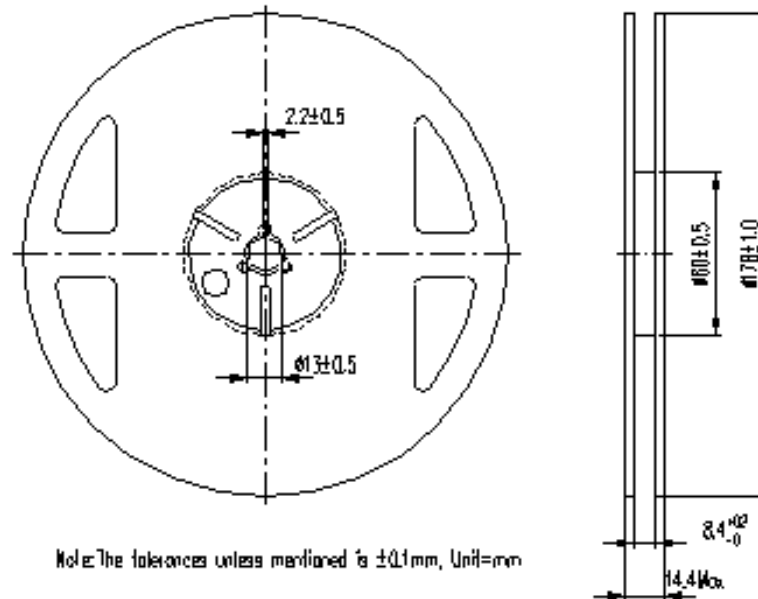

Notes:

1. Empty component pockets sealed with top cover tape.
2. 7 inch reel and typical quantity is 1500 pieces per reel.
3. The maximum number of consecutive missing lamps is two.
4. In accordance with EIA-481-1-B specifications.

8. CAUTIONS

Application

The LEDs described here are intended to be used for ordinary electronic equipment (such as office equipment, communication equipment and household applications). Consult Liteon's Sales in advance for information on applications in which exceptional reliability is required, particularly when the failure or malfunction of the LEDs may directly jeopardize life or health (such as in aviation, transportation, traffic control equipment, medical and life support systems and safety devices).

Storage

This product is qualified as Moisture sensitive Level 3 per JEDEC J-STD-020 Precaution when handling this moisture sensitive product is important to ensure the reliability of the product.

The package is sealed:

The LEDs should be stored at 30°C or less and 90%RH or less. And the LEDs are limited to use within one year, while the LEDs is packed in moisture-proof package with the desiccants inside.

The package is opened:

The LEDs should be stored at 30°C or less and 60%RH or less. Moreover, the LEDs are limited to solder process within 168hrs. If the Humidity Indicator shows the pink color in 10% even higher or exceed the storage limiting time since opened, that we recommended to baking LEDs at 60°C at least 48hrs. To seal the remainder LEDs return to package, it's recommended to be with workable desiccants in original package.

Soldering

Recommended soldering conditions:

Reflow soldering		Soldering iron	
Pre-heat	150~200°C	Temperature	300°C Max.
Pre-heat time	120 sec. Max.	Soldering time	3 sec. Max. (one time only)
Peak temperature	260°C Max.		
Soldering time	10 sec. Max.(Max. two times)		

Drive Method

An LED is a current-operated device. In order to ensure intensity uniformity on multiple LEDs connected in parallel in an application, it is recommended that a current limiting resistor be incorporated in the drive circuit, in series with each LED as shown in Circuit A below.

Circuit model A

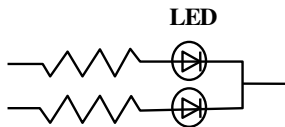

(A) Recommended circuit.

Circuit model B

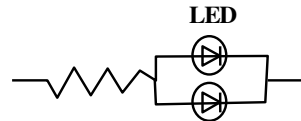

(B) The brightness of each LED might appear different due to the differences in the I-V characteristics of those LEDs.

ESD (Electrostatic Discharge)

Static Electricity or power surge will damage the LED.

Suggestions to prevent ESD damage:

- Use of a conductive wrist band or anti-electrostatic glove when handling these LEDs.
- All devices, equipment, and machinery must be properly grounded.
- Work tables, storage racks, etc. should be properly grounded.
- Use ion blower to neutralize the static charge which might have built up on surface of the LED's plastic lens as a result of friction between LEDs during storage and handling.

ESD-damaged LEDs will exhibit abnormal characteristics such as high reverse leakage current, low forward voltage, or "no light-up" at low currents.

To verify for ESD damage, check for "light-up" and V_f of the suspect LEDs at low currents.

The V_f of "good" LEDs should be $>2.0V@0.1mA$ for InGaN product

Others

The appearance and specifications of the product may be modified for improvement without prior notice.

Suggested Checking List

Training and Certification

1. Everyone working in a static-safe area is ESD-certified?
2. Training records kept and re-certification dates monitored?

Static-Safe Workstation & Work Areas

1. Static-safe workstation or work-Sreas have ESD signs?
2. All surfaces and objects at all static-safe workstation and within 1 ft measure less than 100V?
3. All ionizer activated, positioned towards the units?
4. Each work surface mats grounding is good?

Personnel Grounding

1. Every person (including visitors) handling ESD sensitive (ESDS) items wear wrist strap, heel strap or conductive shoes with conductive flooring?
2. If conductive footwear used, conductive flooring also present where operator stand or walk?
3. Garments, hairs or anything closer than 1 ft to ESD items measure less than 100V*?
4. Every wrist strap or heel strap/conductive shoes checked daily and result recorded for all DLs?
5. All wrist strap or heel strap checkers calibration up to date?

Note: *50V for Blue LED.

Device Handling

1. Every ESDS items identified by EIA-471 labels on item or packaging?
2. All ESDS items completely inside properly closed static-shielding containers when not at static-safe workstation?
3. No static charge generators (e.g. plastics) inside shielding containers with ESDS items?
4. All flexible conductive and dissipative package materials inspected before reuse or recycle?

Others

1. Audit result reported to entity ESD control coordinator?
2. Corrective action from previous audits completed?
3. Are audit records complete and on file?

9. Datasheet Version:

Version	Date	Owner	Change Item
1	2015/11/27	DavidKao	Initial specification
2	2016/01/29	DavidKao	Update max DC forward current 60mA for maximum ratings (Page 3) Update format for electrical / optical characteristics curves Fig.1 ~ Fig.4 (Page 5-6)
3.	2016/02/03	ChunChieh	<ol style="list-style-type: none"> 1. Change Absolute Maximum Ratings: Power Dissipation (P_o) to 240mW Junction Temperature (T_j) to 90 °C (Page.3) 2. Change Electro-Optical Characteristics: Radiant flux (Φ_e) range to 10 ~ 20 mW Radiant flus Bin table : R1 to R5 (Page.3, 4) 3. Modify Suggest IR Reflow Condition (Page 7) 4. Change Packge Qty per reel: Typ. 1500pcs/reel, Min. 100pcs/reel for remainders (Page 9)
3.1	2016/02/26	ChunChieh	<ol style="list-style-type: none"> 1. Change Electro-Optical Characteristics: Peak Wavelength Spec table (Page 4)
3.2	2016/08/29	ChunChieh	<ol style="list-style-type: none"> 1. Change Electro-Optical Characteristics: Radiant Flux Spec table (Page 4)
3.3	2016/10/25	ChunChieh	<ol style="list-style-type: none"> 1. Modify Radiant Flux Spec: Add R8 Bin, Remove R2 Bin (Page 4)