

ELUA2835TG0 Series



Features

- Ultraviolet LED
- Dimension 2.8mm*3.5mm
- RoHS compliant
- Pb free
- The product itself will remain within RoHS compliant version.
- Compliance with EU REACH.
- Compliance Halogen Free .(Br <900 ppm ,Cl <900 ppm , Br+Cl < 1500 ppm).

Description

The Everlight ELUA2835 package has high efficacy, low power consumption, wide viewing angle and a compact form factor that is suitable for UVA application

Applications

- UV Nail
- UV Counterfeit
- UV Catch mosquitoes

Product Nomenclature**ELUA2835TG0-PXXXXYY3040060-VA1D**

EL = Everlight

UA = UVA

2835 = 2.8mm x 3.5mm Package

T = Package Material: PCT

G = Coating: Ag

0 = Angle: 100°

P = Peak Wavelength

XXXX = Wavelength Range [1]

YY = Minimum Radiant Flux Spec [2]

3040 = Forward Voltage Spec: 3.0~4.0V

060 = Forward Current: 60mA

V = Chip Type: Vertical

A = Chip Size: 15mil

1 = Chip QTY: 1 chip

D = Process Type: Dispensing

EVERLIGHT

Absolute Maximum Ratings

Parameter	Symbol	Ratings	Unit
Max. DC Forward Current (mA)	I_F	70	mA
Max. ESD Resistance	V_B	2000	V
Thermal Resistance	R_{th}	15	°C/W
Max. Junction Temperature	T_J	90	°C
Operating Temperature	T_{Opr}	-40 ~ +85	°C
Storage Temperature	T_{Stg}	-40 ~ +85	°C

PN of the ELUA2835TG0 series: UVA LEDs

Order Code of ELUA2835TG0	Minimum Radiant Flux (mW)	Typical Radiant Flux (mW)	Maximum Radiant Flux (mW)	Peak Wavelength (nm)	Forward Voltage (V)	Forward Current (mA)
ELUA2835TG0-P6070R53040060-VA1D	70	90	150	360~370	3.0~4.0	60
ELUA2835TG0-P8090R53040060-VA1D	70	90	150	380~390	3.0~4.0	60
ELUA2835TG0-P9000R53040060-VA1D	70	90	150	390~400	3.0~4.0	60
ELUA2835TG0-P0010R53040060-VA1D	70	90	150	400~410	3.0~4.0	60

Product Binning

Radiant Flux Bins

Bin Code	Minimum Radiant Flux (mW)	Maximum Radiant Flux (mW)
R5	70	90
R6	90	110
R9	110	130
S2	130	150

Notes:

1. Radiant flux measurement tolerance: $\pm 10\%$.
2. Forward voltage bins are defined at $I_F=60\text{mA}$ operation.

Peak Wavelength Bins

Bin	Minimum Peak Wavelength (nm)	Maximum Peak Wavelength (nm)
U36	360	370
U38	380	390
U39	390	400
U40	400	410

Notes:

1. Peak Wavelength measurement tolerance: $\pm 1\text{nm}$.
2. Forward voltage bins are defined at $I_F=60\text{mA}$ operation.

Forward Voltage Bins

Bin	Minimum Forward Voltage (V)	Maximum Forward Voltage (V)
3032	3.0	3.2
3234	3.2	3.4
3436	3.4	3.6
3638	3.6	3.8
3840	3.8	4.0

Notes:

1. Forward voltage measurement tolerance: $\pm 2\%$.
2. Forward voltage bins are defined at $I_F=60\text{mA}$ operation.

Mechanical Dimension

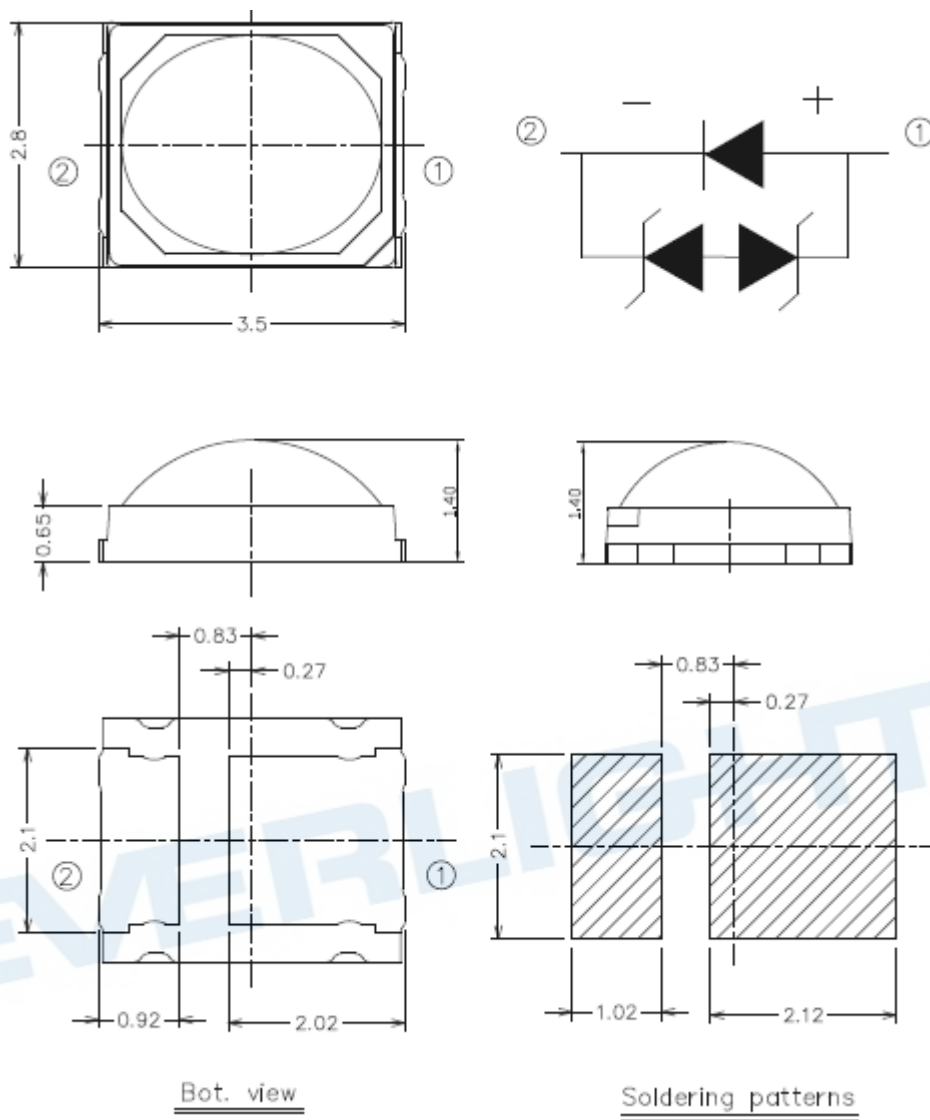

Notes:

1. Dimensions are in millimeters.
2. Tolerances unless mentioned are $\pm 0.2\text{mm}$.
3. The thermal pad is electrically unity from the Cathode and contact pads.
4. Do not handle the device by the lens. Incorrect force applied to the lens may lead to the failure of devices.

Reflow Soldering Characteristics

For Reflow Process

- ELUA series are suitable for SMT processes.
- Curing of glue in oven must be according to standard operation flow processes.

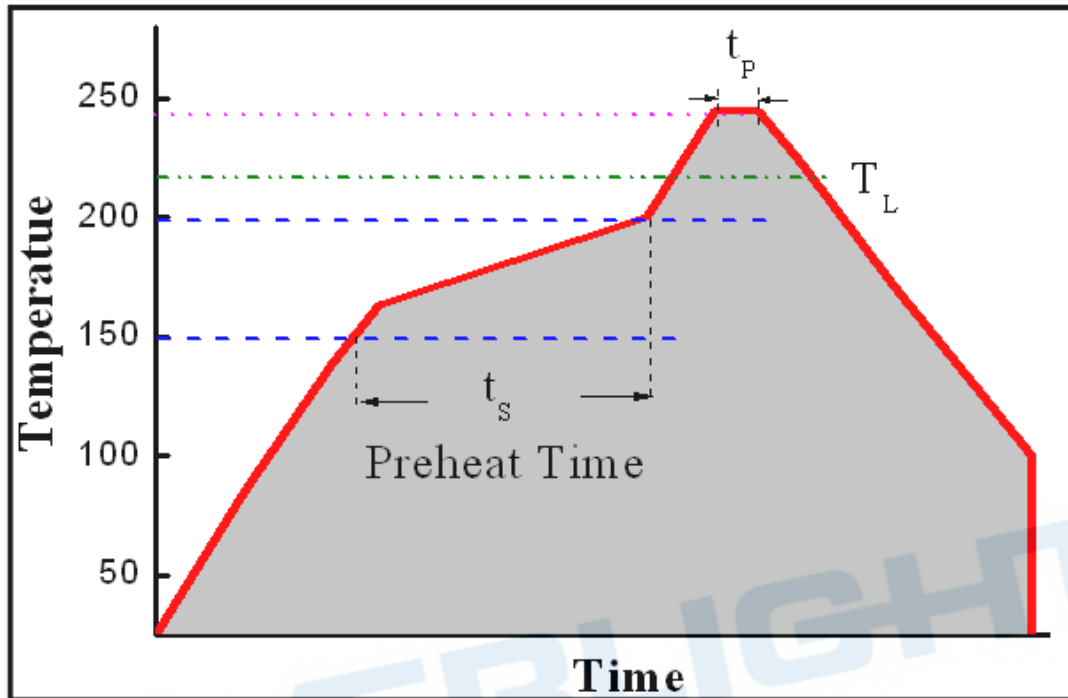

Profile Feature	Lead Free Assembly
Ramp-Up Rate	2-3 °C/S
Preheat Temperature	150-200 °C
Preheat Time (t_s)	60-120 S
Liquid Temperature (T_L)	217 °C
Time maintained above T_L	60-90 S
Peak Temperature (T_p)	240±5 °C
Peak Time (t_p)	Max 20 S
Ramp-Down Rate	3-5 °C/S

- Reflow soldering should not be done more than twice.
- In soldering process, stress on the LEDs during heating should be avoided.
- After soldering, do not bend the circuit board.

Wavelength Characteristics

Relative Spectral Distribution
@ Solder Pad Temperature = 25°C

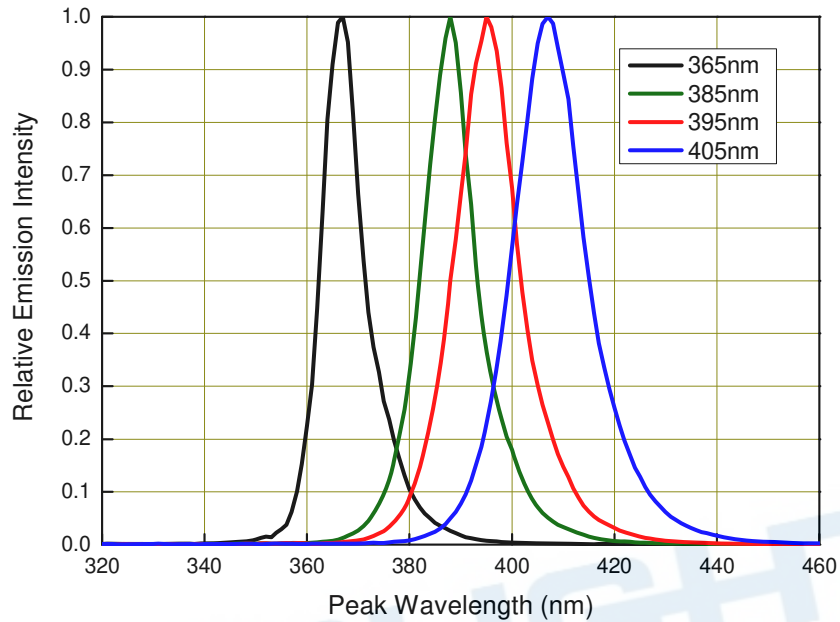

Forward Voltage vs. Forward Current
@ Solder Pad Temperature = 25°C

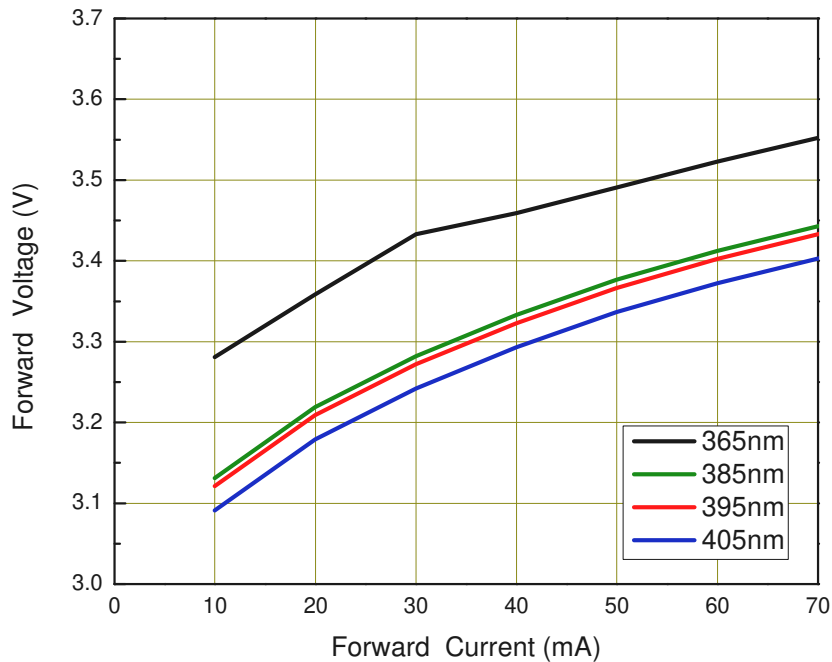

Relative Radiant Flux vs. Forward Current @ Solder Pad Temperature = 25°C

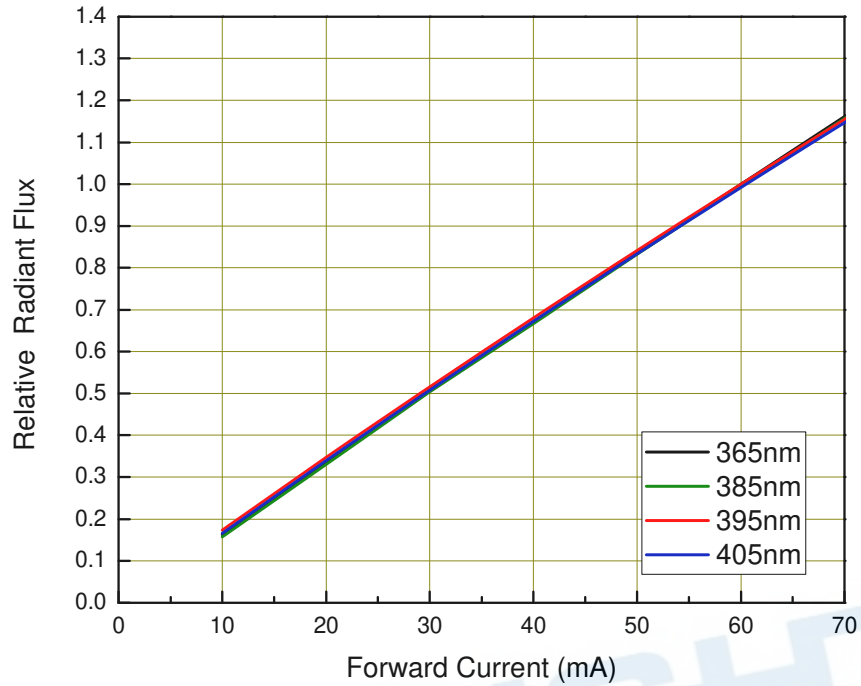

Peak Wavelength vs. Forward Current @ Solder Pad Temperature = 25°C

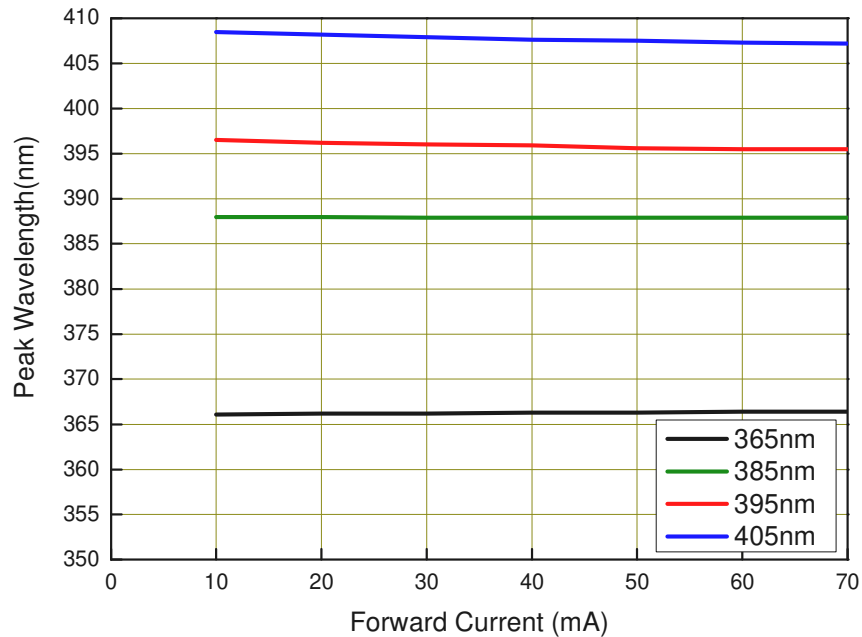

Relative Radiant Flux vs. Junction Temperature @Forward Current = 60mA

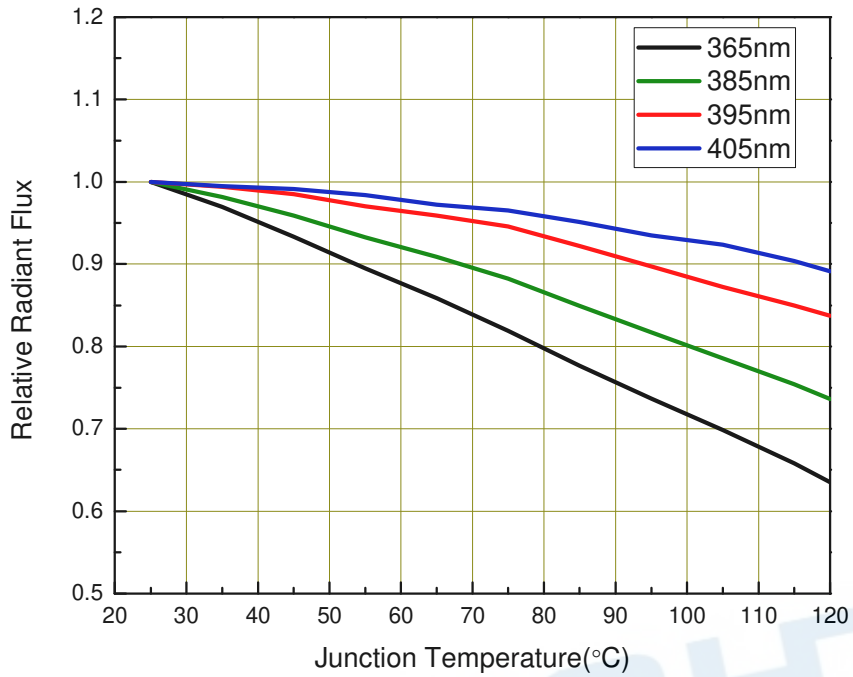

Forward Voltage vs. Junction Temperature @Forward Current = 60mA

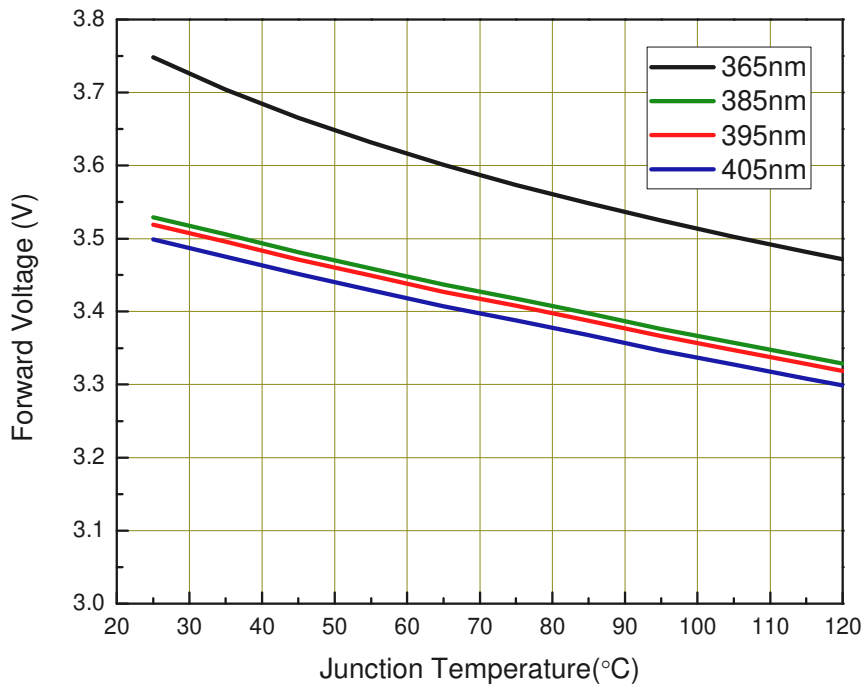

Peak Wavelength vs. Junction Temperature @Forward Current = 60mA

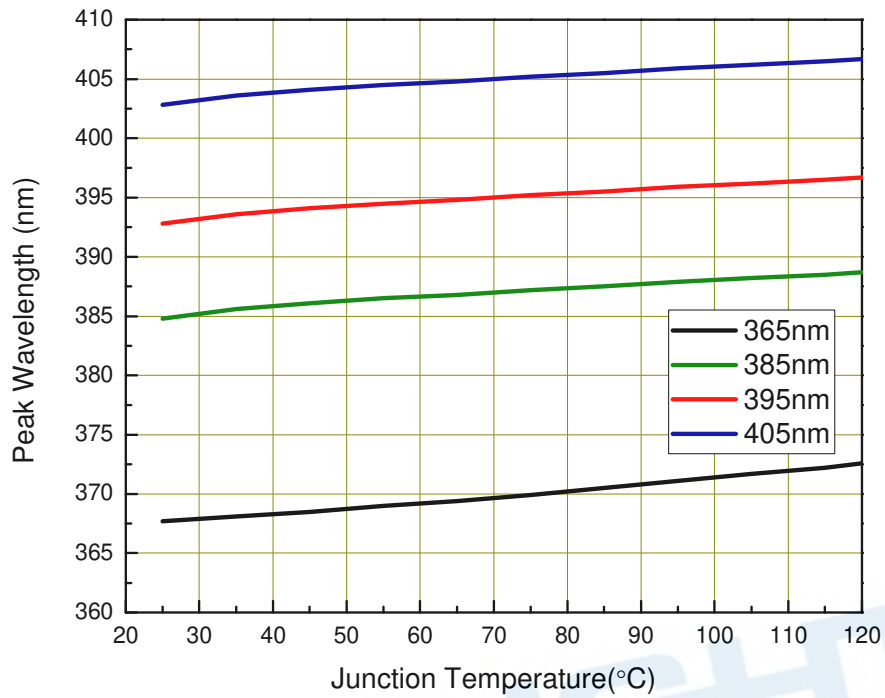

Derating Curve

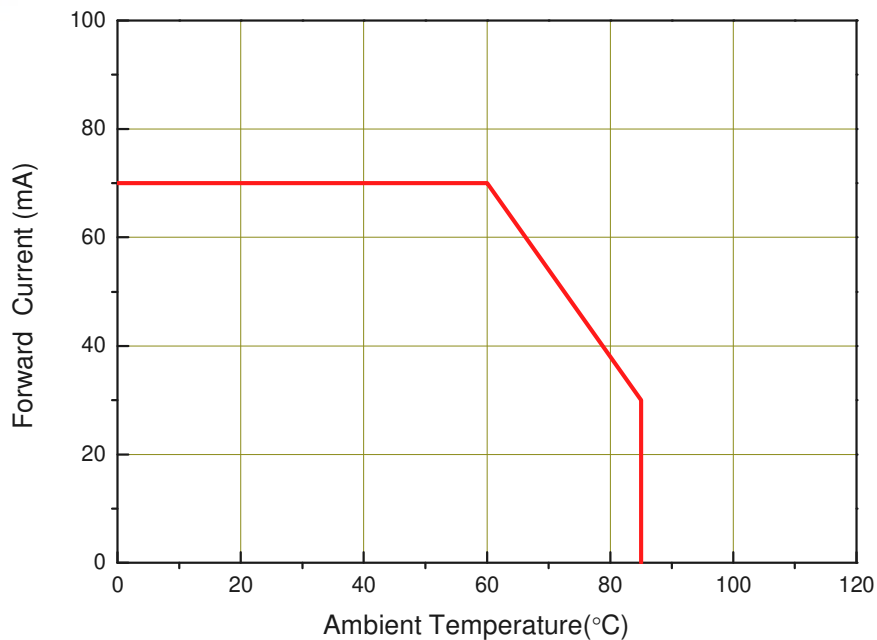

Typical Radiation Patterns

Typical Diagram Characteristics of Radiation for ELUA2835TG0

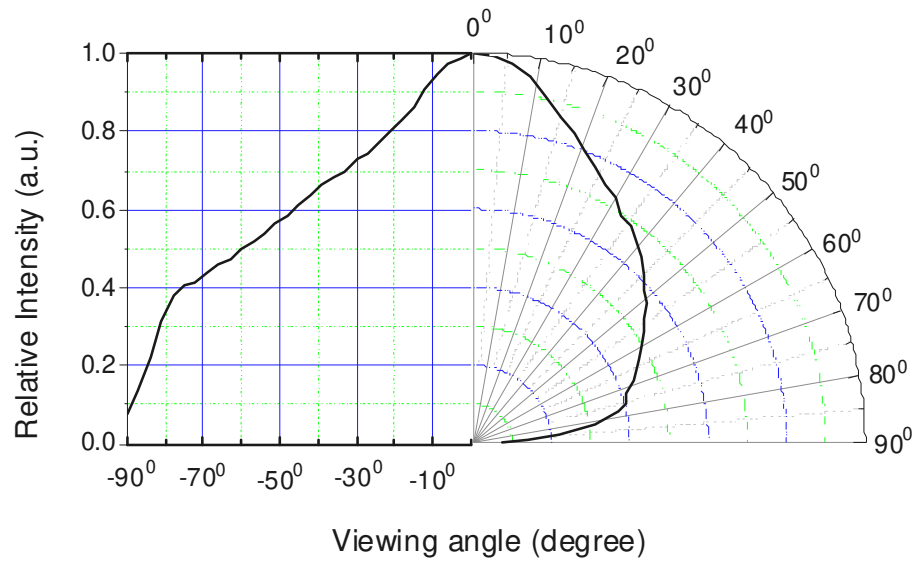
**Notes:**

1. $\theta_{1/2}$ is the off axis angle from lamp centerline where the luminous intensity is 1/2 of the peak value.
2. View angle tolerance is $\pm 5^\circ$

Emitter Tape Packaging

Carrier Tape Dimensions as the following:

Reel: 2000pcs

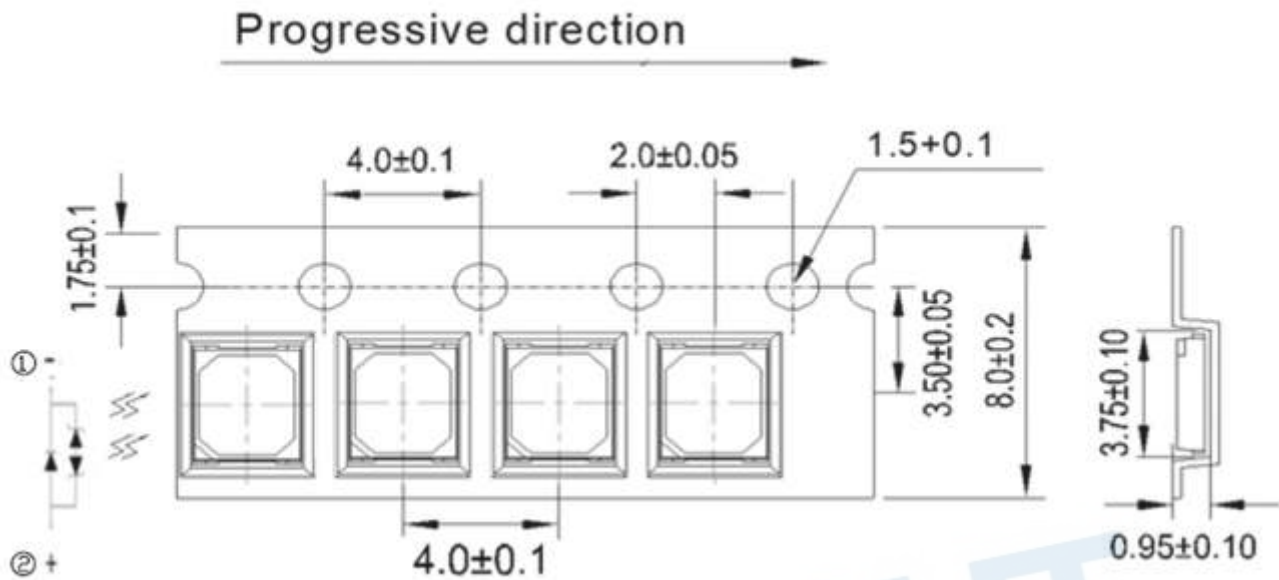

Unit = mm

Notes:

1. Tolerance unless mentioned is ± 0.1 mm;
2. smallest packing quantity do not be smaller 200PCS

Moisture Resistant Packaging

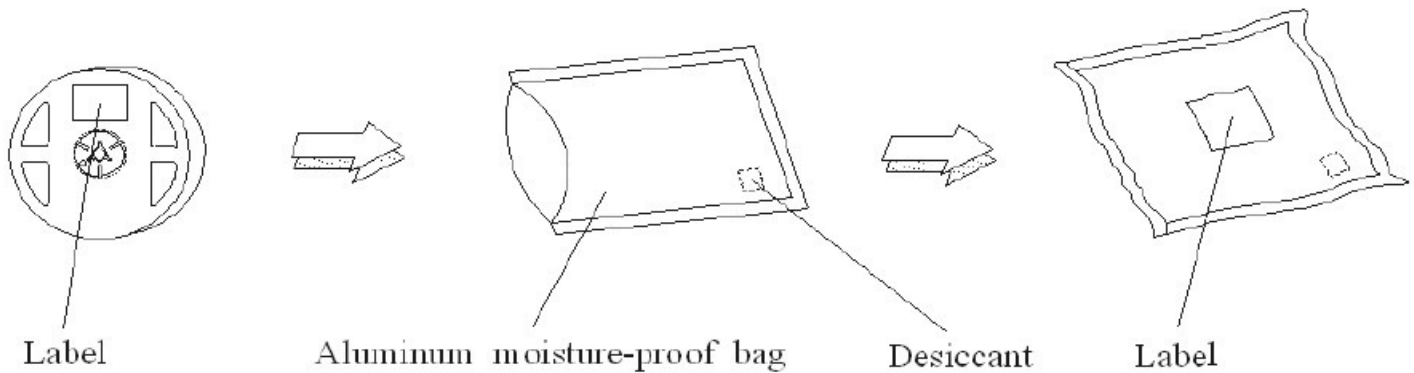

Emitter Reel Dimensions

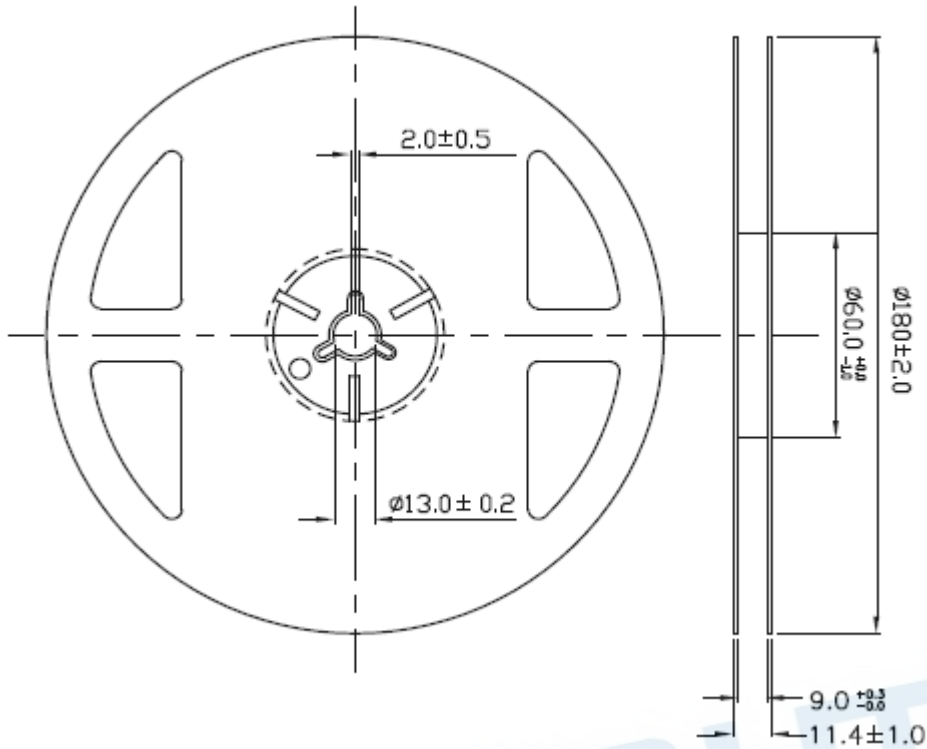

Notes:

1. Dimensions are in millimeters.
2. Tolerances unless mentioned are ± 0.1 mm.

Label Explanation

CPN: Customer Specification (when required)

P/N : Everlight Production Number

QTY: Packing Quantity

CAT: Luminous Flux (Brightness) Bin

HUE: Color Bin

REF: Forward Voltage Bin

LOT No: Lot Number

MADE IN TAIWAN: Production Place

Product Labeling

RoHS (Pb) EVERLIGHT 5

CPN: XXXXXXXXXXXXXXXXXXXX



XXXXXXXXXX-XXXXXXXXXX-XXXXXXXXXX-XXXXXXXXXX-XXXXXX

P/N: XXXXXXXXXXXX



XXXXXXXXXX-XXXXXXXXXX-XXXXXXXXXX-XXXXXXXXXX-XXXXXX

LOT NO: Y150716XXX-XXXXXXXXXX-XXXXXXXXXX



QTY: 0123456789 HUE: XXXXXXXXXXXX



CAT: XXXXXXXXXXXX REF: XXXXXXXXXXXX



CE: BTPYMMDDXXXXX



MADE IN XXXXXX



Precautions for Use

1. Over-current-proof

Customer must apply resistors for protection; otherwise slight voltage shift will cause big current change (Burn out will happen).

2. Assemblies

Do not stack assemblies containing Everlight ELUA2835 LEDs to prevent damage to the optical surface of LEDs. Forces applied to the optical surface may result in the surface being damaged.

3. Soldering Condition

3.1 Pb-free solder temperature profile

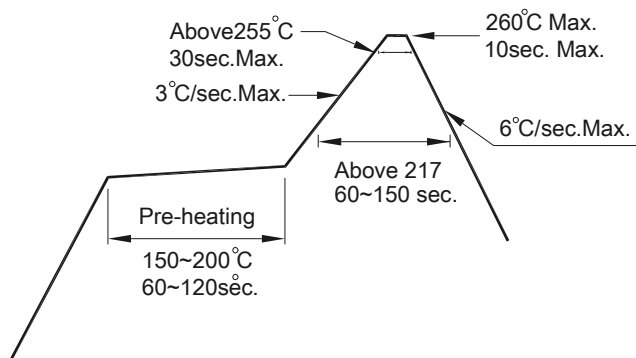

3.2 Reflow soldering should not be done more than two times.

3.3 When soldering, do not put stress on the LEDs during heating.

3.4 After soldering, do not warp the circuit board.

4. Soldering Iron

Each terminal is to go to the tip of soldering iron temperature less than 350°C for 3 seconds within once in less than the soldering iron capacity 25W. Leave two seconds and more intervals, and do soldering of each terminal. Be careful because the damage of the product is often started at the time of the hand solder.

5. Repairing

Repair should not be done after the LEDs have been soldered. When repairing is unavoidable, a double-head soldering iron should be used (as below figure). It should be confirmed beforehand whether the characteristics of the LEDs will or will not be damaged by repairing.

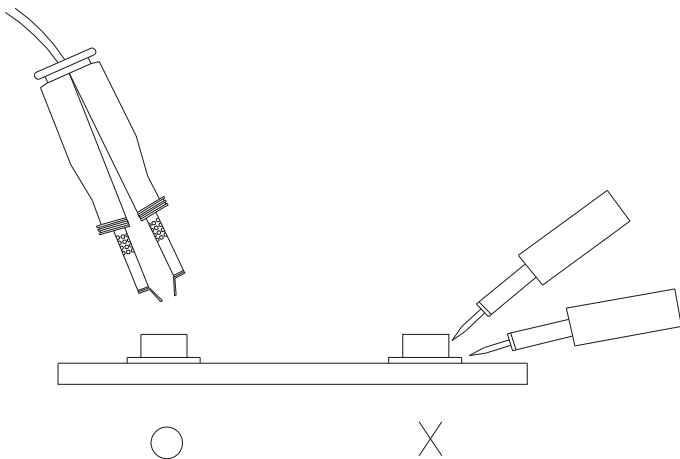

Storage Conditions

- Before the package is opened. The LEDs should be stored at 30°C or less and 90%RH or less after being shipped from EVERLIGHT and the storage life limits are 12 months.
- After opening the package: The LED's floor life is 168 hours under 30°C or less and 60% RH or less. If unused LEDs remain, it should be stored in moisture proof packages.
- If the moisture absorbent material (silica gel) has faded away or the LEDs have exceeded the storage time, baking treatment should be performed using the following conditions. Baking treatment: 60±5°C for 24 hours.

DISCLAIMER

- EVERLIGHT reserves the right(s) on the adjustment of product material mix for the specification.
- The product meets EVERLIGHT published specification for a period of twelve (12) months from date of shipment.
- The graphs shown in this datasheet are representing typical data only and do not show guaranteed values.
- When using this product, please observe the absolute maximum ratings and the instructions for using outlined in these specification sheets. EVERLIGHT assumes no responsibility for any damage resulting from the use of the product which does not comply with the absolute maximum ratings and the instructions included in these specification sheets.
- These specification sheets include materials protected under copyright of EVERLIGHT. Reproduction in any form is prohibited without obtaining EVERLIGHT's prior consent.
- This product is not intended to be used for military, aircraft, automotive, medical, life sustaining or life saving applications or any other application which can result in human injury or death. Please contact authorized EVERLIGHT sales agent for special application request.
- The product is not suitable for use in an ammonia environment.