



Specific Lighting Product Data Sheet LTPL-C036UVG365

Spec No. :DS23-2019-0011
Effective Date: 07/23/2020
Revision: A

LITE-ON DCC

RELEASE

Specific Lighting LTPL-C036UVG365

1. Description

The LiteON C03 UV Product series is a revolutionary, energy efficient light source for UV curing and common UV application, combining the lifetime and reliability advantages of Light Emitting Diodes with the brightness of conventional light source. It gives you design freedom, and creating a new opportunities for solid state UV light source to displace conventional UV technologies

Features

- I.C. compatible
- RoHS compliant and Pb free
- Lower operating costs
- Reduced maintenance costs

2. Outline Dimensions

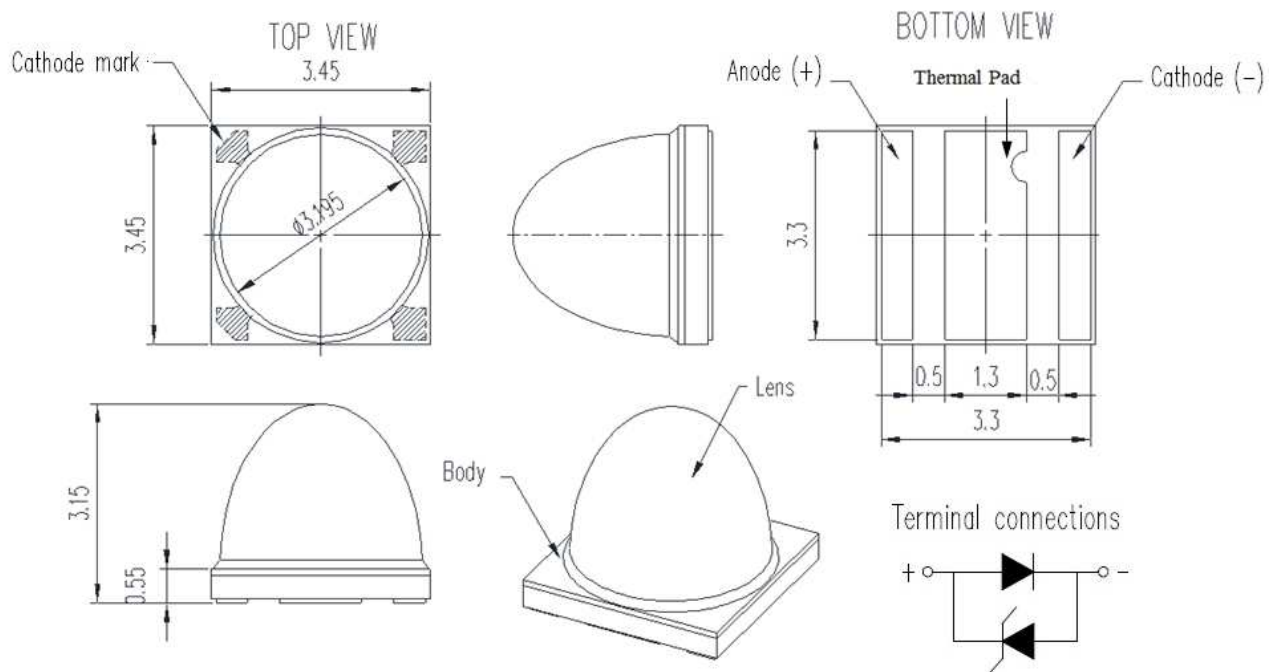

Notes :

1. All dimensions are in millimeters and dimension tolerances are $\pm 0.2\text{mm}$ except lens height and ceramic length / width dimension tolerance are $\pm 0.1\text{mm}$
2. Thermal pad of the device is electrically neutral from the anode and cathode pads

**Specific Lighting
LTPL-C036UVG365**

3. Absolute Maximum Ratings at Ta=25°C

Parameter	Symbol	Rating	Unit
DC Forward Current	<i>I_f</i>	700	mA
Power Consumption	<i>P_o</i>	2.94	W
Operating Temp Range	<i>T_{opr}</i>	-40 ~ +85	°C
Storage Temp Range	<i>T_{stg}</i>	-55 ~ +100	°C
Junction Temperature	<i>T_j</i>	110	°C

Notes:

Operating the LED under reverse bias condition long time might result in damage or failure of the component.

**Specific Lighting
LTPL-C036UVG365**

4. Electro-Optical Characteristics at Ta=25°C

Parameter	Symbol	Values		Test Condition	Unit
Forward Voltage	V_f	Min.	2.8	$I_f = 500\text{mA}$	V
		Typ.	3.6		
		Max.	4.4		
Radiant Flux	Φ_e	Min.	762	$I_f = 500\text{mA}$	mW
		Typ.	905		
		Max	1123		
Peak Wavelength	λ_p	Min.	360	$I_f = 500\text{mA}$	nm
		Max	370		
Viewing Angle	$2\theta_{1/2}$	Typ.	55	$I_f = 500\text{mA}$	°
Thermal Resistance	$R_{th_{js}}$	Typ	5.0	---	°C/W

Notes:

1. Radiant flux (Φ_e) is the total Radiant flux output as measured with an integrating sphere.
2. Thermal resistance (Junction to solder) measurement tolerance is $\pm 10\%$

**Specific Lighting
LTPL-C036UVG365**

5. Bin Code List

<i>V_f</i> : Forward Voltage Spec. Table		
<i>V_f</i> Bin	<i>V_f</i> (V) @ <i>I_f</i> = 500mA	
	Min.	Max.
V1	3.2	3.6
V2	3.6	4.0
V3	4.0	4.4

Forward Voltage Tolerance: +/- 0.1 V

<i>mW</i> : Radiant Flux Spec. Table		
<i>mW</i> Bin	<i>mW</i> @ <i>I_f</i> = 500mA	
	Min.	Max.
NO	762	824
OP	824	890
PR	890	961
RS	961	1039
ST	1039	1123

Radiant Flux Tolerance: +/- 10%

<i>W_p</i> : Peak Wavelength Spec table		
<i>W_p</i> Bin	<i>W_p</i> (nm) @ <i>I_f</i> = 500mA	
	Min.	Max.
P3M	360	365
P3N	365	370

Peak Wavelength Tolerance: +/- 3nm

Notes:

1. Bin classification code is marked on each packing bag.

**Specific Lighting
LTPL-C036UVG365**

6. Typical Electrical / Optical Characteristics Curves

(25°C Ambient Temperature Unless Otherwise Noted)

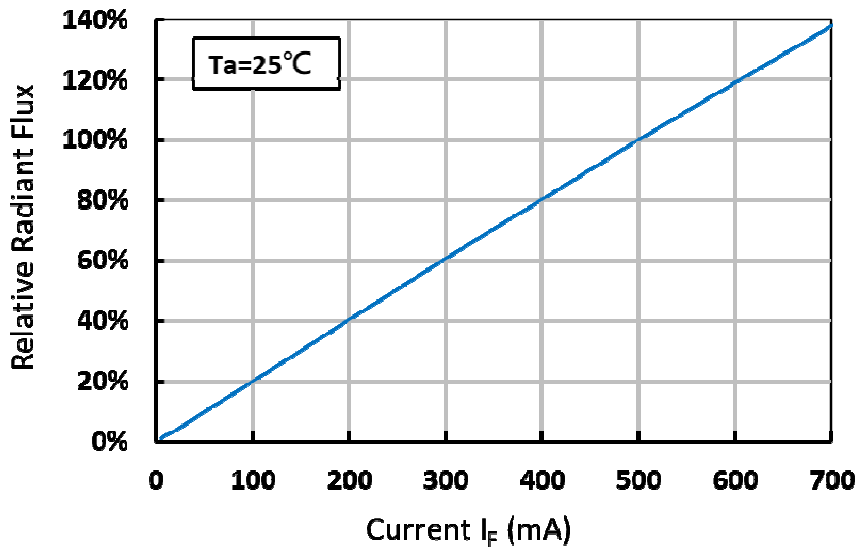

Fig 1. Relative Radiant Flux vs. Forward Current

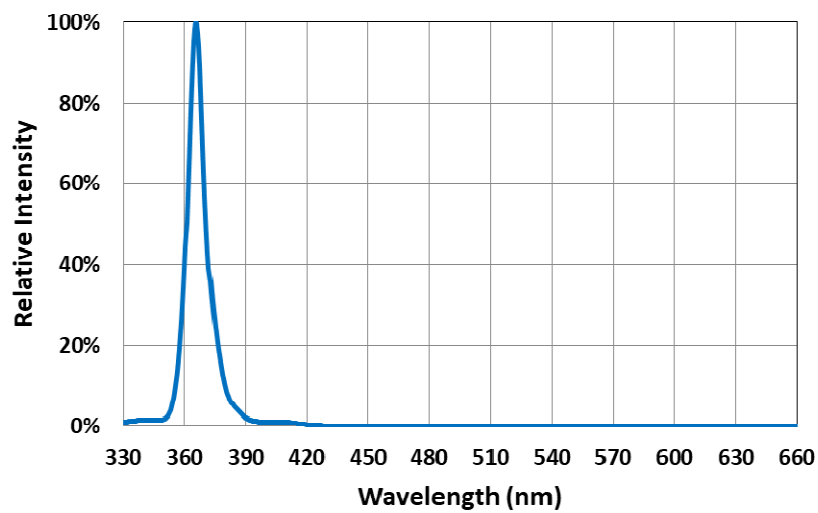

Fig 2. Relative Spectral Distribution

**Specific Lighting
LTPL-C036UVG365**

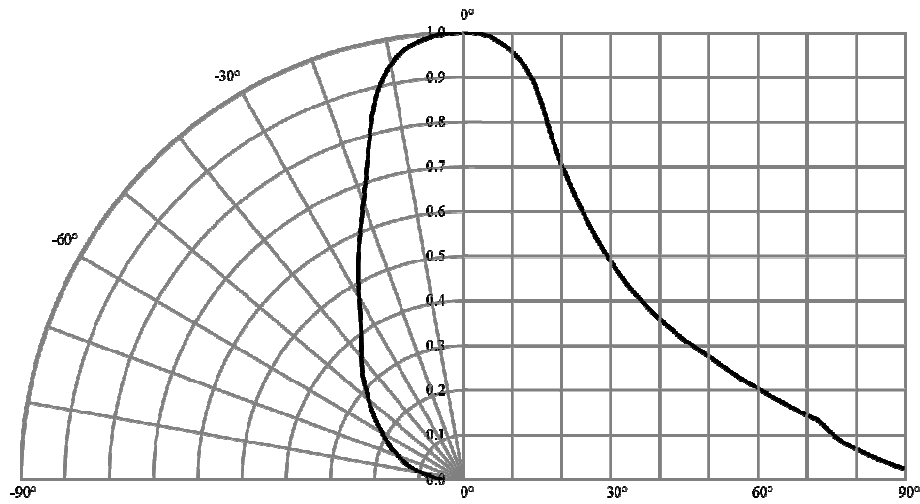

Fig 3. Radiation Characteristics

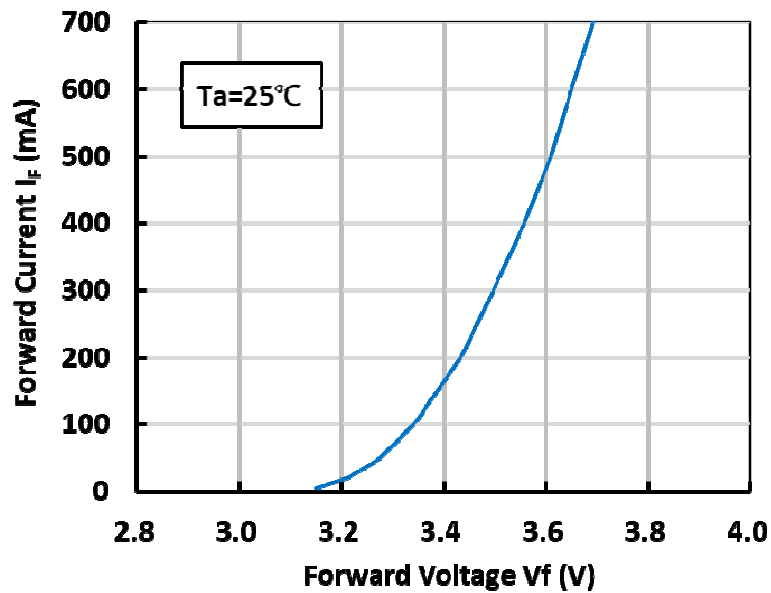

Fig 4. Forward Current vs. Forward Voltage

**Specific Lighting
LTPL-C036UVG365**

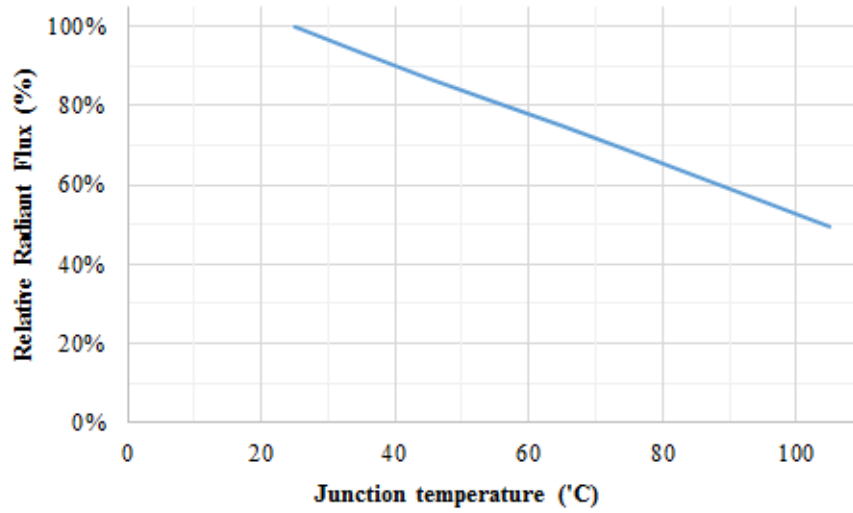

Fig.5 Relative Radiant Flux vs Junction Temperature

Specific Lighting LTPL-C036UVG365

7. Reliability Test Plan

No	Test item	Condition	Duration	Number of Failed
1	Low Temperature Operating Life (LTOL)	$T_c = -10^\circ\text{C}$, $I_f = 700\text{mA}$	1000 hrs	0/10
2	Room Temperature Operating Life (RTOL)	25°C , $I_f = 700\text{mA}$	1000 hrs	0/10
3	High Temperature Operating Life (HTOL)	$T_c = 85^\circ\text{C}$, $I_f = 60\text{mA}$	1000 hrs	0/10
4	Wet High Temperature Operating Life (WHTOL)	$60^\circ\text{C}/90\%\text{RH}$, $I_f = 350\text{mA}$	500 hrs	0/10
5	Non-Operating Thermal Shock (TMSK)	-40°C to 125°C 30 minutes dwell, <10 seconds transfer	100 cycles	0/10
6	High temperature storage	$T_A = 100^\circ\text{C}$	1000 hrs	0/10

Notes:

1. Operating life test are mounted on thermal heat sink
2. Storage item are only component, not put on heat sink.

Criteria for Judging the Damage

Item	Symbol	Test Condition	Criteria for Judgment	
			Min.	Max.
Forward Voltage	V_f	$I_f = \text{Typical Current}$	-10%	+10%
Radiant Flux	Φ_e	$I_f = \text{Typical Current}$	-15%	+15%

Specific Lighting LTPL-C036UVG365

8. User Guide

Suggested Reflow Soldering Characteristics

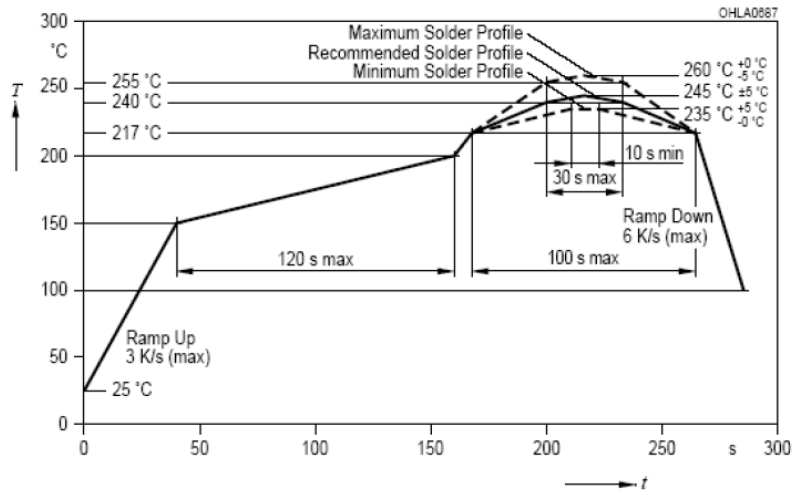

Notes:

1. All temperatures refer to topside of the package, measured on the package body surface.
2. The soldering profile could be further referred to different soldering grease material characteristic. The grease vendor will provide this information.
3. A rapid-rate process is not recommended for the LEDs cooling down from the peak temperature.
4. Although the recommended reflow conditions are specified above, the reflow or hand soldering condition at the lowest possible temperature is desirable for the LEDs.
5. LiteOn cannot make a guarantee on the LEDs which have been already assembled using the dip soldering method.

Specific Lighting LTPL-C036UVG365

Recommend Printed Circuit Board Attachment Pad

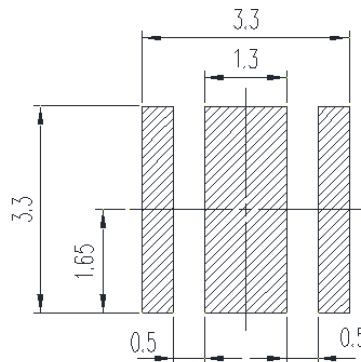

Notes:

1. The LEDs can be soldered using the reflow soldering or hand soldering method. The recommended hand soldering condition is 300°C max. and 2secs max. on ly once, and the operation of reflow soldering is only up to three times at maximum.
2. All temperatures refer to topside of the package, measured on the package body surface.
3. The soldering profile could be further referred to different soldering grease material characteristic. The grease vendor will provide this information.
4. A rapid-rate process is not recommended for the LEDs cooling down from the peak temperature.
5. Although the recommended reflow conditions are specified above, the reflow or hand soldering condition at the lowest possible temperature is desirable for the LEDs.
6. LiteOn cannot make a guarantee on the LEDs which have been already assembled using the dip soldering method.

Specific Lighting LTPL-C036UVG365

Package Dimensions of Tape

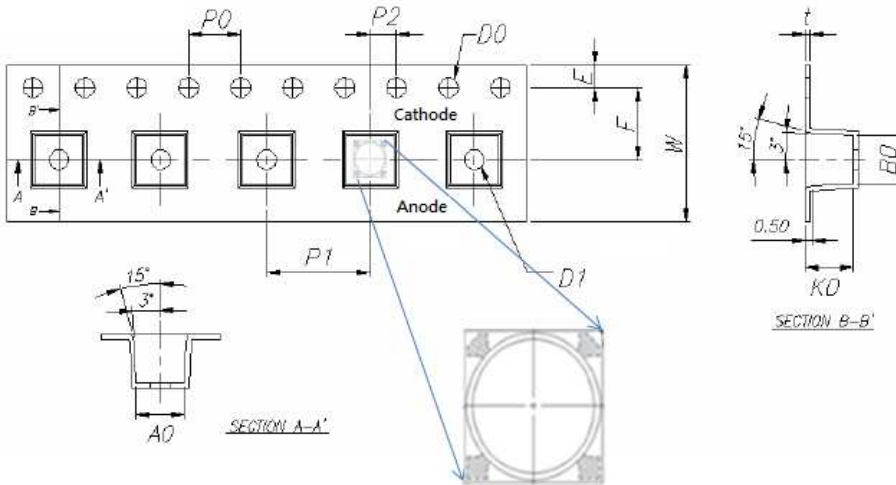

Item	Specification	Tol. (+/-)
W	12.00	± 0.30
E	1.75	± 0.10
F	5.50	± 0.10
D0	1.50	+0.10, -0
D1	1.50	+0.10, -0
P0	4.00	± 0.10
P1	8.00	± 0.10
P2	2.00	± 0.05
P0 x 10	40.00	± 0.20

t	0.35	± 0.05
A0	3.70	± 0.10
B0	3.70	± 0.10
K0	3.50	± 0.10

Package Dimensions of Reel

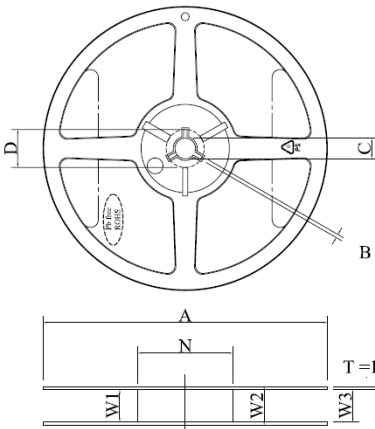

A	N	W1	W2	W3	D	B	C
178±1.0	60±1.5	12.4 ^{+2.0} _{-0.0}	15.0±1.0	> 12	21.0±0.8	2.2±0.5	13.0 ^{+0.5} _{-0.2}

Notes:

1. Empty component pockets sealed with top cover tape.
2. 7 inch reel-maximum 500 pieces per reel.
3. The maximum number of consecutive missing lamps is two.
4. In accordance with EIA-481-1-B specifications.

Specific Lighting LTPL-C036UVG365

9. Cautions

Cleaning

Use alcohol-based cleaning solvents such as isopropyl alcohol to clean the LED if necessary.

Do not use unspecified chemical liquid to clean LED, it could harm the package.

Drive Method

An LED is a current-operated device. In order to ensure intensity uniformity on multiple LEDs connected in parallel in an application, it is recommended that a current limiting resistor be incorporated in the drive circuit, in series with each LED as shown in Circuit below.

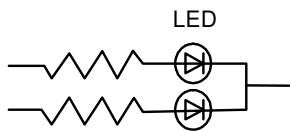

Circuit model A

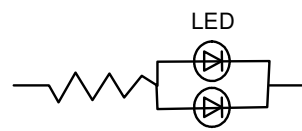

Circuit model B

(A) Recommended circuit.

(B) The brightness of each LED might appear different due to the differences in the I-V characteristics of those LEDs.

© This LED should be used under forward current, particularly not used under continuous reverse current to avoid the damage to LED.

The electrode pads are plated with gold, but it is still not recommended to the use under any of the following conditions, please confirm the performance and reliability are well enough if you use it under any of the following conditions

- Do not use sulfur-containing materials in commercial products including the materials such as seals and adhesives that may contain sulfur.
- Do not put this product in a place with a lot of moisture (over 85% relative humidity), dew condensation, briny air, and corrosive gas (Cl, H₂S, NH₃, SO₂, NO_x, etc.).

Manual Handling Remark

The LED should only be picked up by making contact with the sides of the LED body. It should not put any pressure on the lens either by finger or any hand tool. Do not puncture or push the lens.

Specific Lighting LTPL-C036UVG365

ESD (Electrostatic Discharge)

Static Electricity or power surge will damage the LED. Suggestions to prevent ESD damage:

- Use a conductive wrist band or anti-electrostatic glove when handling these LEDs.
- All devices, equipment, and machinery must be properly grounded.
- Work tables, storage racks, etc. should be properly grounded.
- Use ion blower to neutralize the static charge which might have built up on surface of the LED's plastic lens as a result of friction between LEDs during storage and handling.

ESD-damaged LEDs will exhibit abnormal characteristics such as high reverse leakage current, low forward voltage, or "no light up" at low currents. To verify for ESD damage, check for "light up" and V_F of the suspect LEDs at low currents. The V_F of "good" LEDs should be $>2.0V@0.5mA$

Training and Certification

1. Working area is ESD-certified.
2. Training records and re-certification dates monitored.

Static-Safe Workstation & Work Areas

1. Static-safe working stations or work-areas have ESD signs.
2. All surfaces and objects at all static-safe workstation and within 1 ft measure less than 100V.
3. All ionizer activated, positioned towards the units.
4. Each work surface mats grounding is good.

Personnel Grounding

1. Every person (including visitors) handling ESD sensitive (ESDS) items wear wrist strap, heel strap or conductive shoes with conductive flooring.
2. If conductive footwear used, conductive flooring also present.
3. Garments, hairs or anything closer than 1 ft to ESD items measure less than 100V.
4. The wrist strap or heel strap/conductive shoes are checked daily and result recorded.
5. All wrist strap or heel strap checkers calibration up to date.

Device Handling

1. Each ESDS items identified by EIA-471 labels on item or packaging..
2. No static charge generators (e.g. plastics) inside shielding containers with ESDS items.
3. All flexible conductive and dissipative package materials are inspected before reuse or recycles

Specific Lighting LTPL-C036UVG365

Storage

This product is qualified as Moisture sensitive Level 3 per JEDEC J-STD-020 Precaution when handling this moisture sensitive product is important to ensure the reliability of the product.

The package is sealed:

The LEDs should be stored at 30°C or less and 85%RH or less. And the LEDs are limited to use within one year, while the LEDs is packed in moisture-proof package with the desiccants inside.

The package is opened:

The LEDs should be stored at 30°C or less and 60%RH or less. The LEDs are limited to solder process within 168hrs. If the Humidity Indicator shows the pink color in 10% even higher or exceed the storage limiting time since opened, we recommended to baking LEDs at 60°C at least 24hours before solder. To seal the remainder LEDs return to package, it's recommended to be with workable desiccants in original package.

Safety

Do NOT directly look at the UV light from LED or optical instrument because it is harmful to human eyes. And it is recommended to use UV goggles protective glasses for avoiding eye damage.