



Specific Lighting Product Data Sheet LTPL-G35UV275UZ

Spec No. :DS23-2023-0021
Effective Date: 06/28/2023
Revision: -

LITE-ON DCC

RELEASE

Specific Lighting LTPL-G35UV275UZ

1. Description

The LITEON LTPL-G35 UVC product series is a revolutionary, energy efficient light source for sterilization and medical application, combining the lifetime and reliability advantages of Light Emitting Diodes with the brightness of conventional light source. It gives you design freedom, and creating a new opportunity for solid state UVC light source to displace conventional UV technologies.

Features

- I.C. compatible
- RoHS compliant and Pb free
- Lower operating costs
- Reduced maintenance costs

2. Outline Dimensions

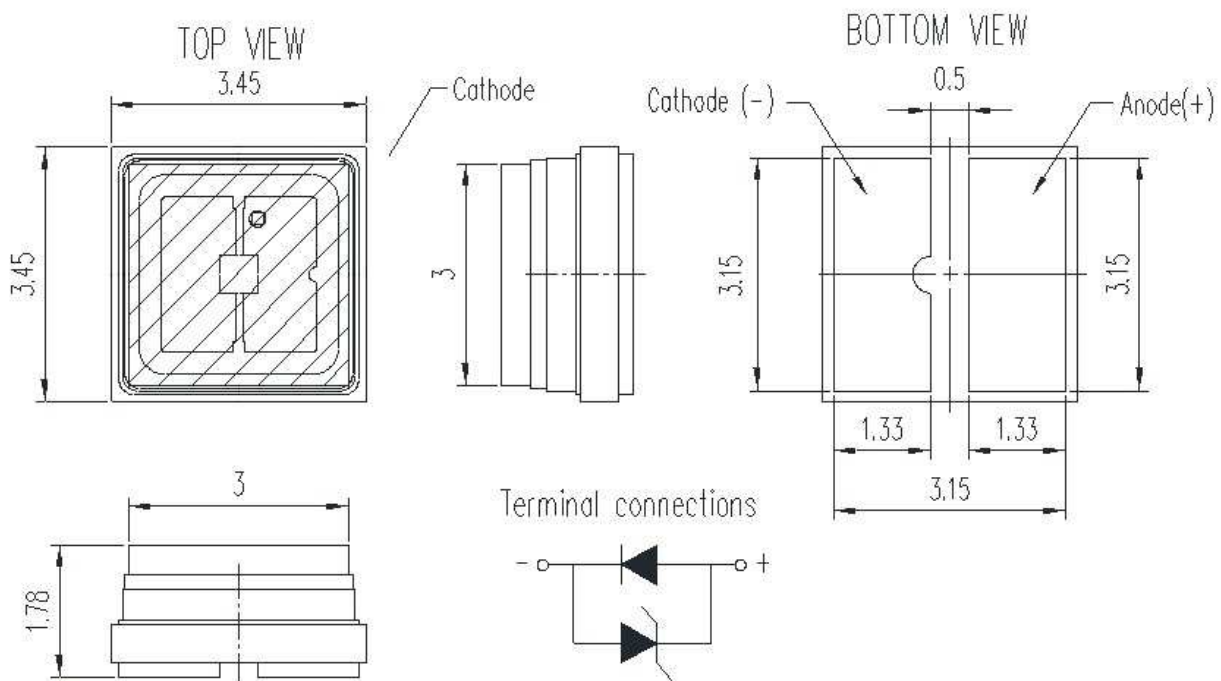

Notes:

All dimensions are in millimeters and tolerance is $\pm 0.2\text{mm}$ unless otherwise noted.

Specific Lighting LTPL-G35UV275UZ

3. Absolute Maximum Ratings at Ta=25°C

Parameter	Symbol	Rating	Unit
Power Dissipation	P_o	3.8	W
DC Forward Current	I_F	500	mA
Operating Temperature Range	T_{opr}	-40~+80	°C
Storage Temperature Range	T_{stg}	-40~+100	°C
Junction Temperature	T_j	115	°C

Notes:

Operating the LED under reverse bias condition long time might result in damage or failure of the component.

Specific Lighting LTPL-G35UV275UZ

4. Electro-Optical Characteristics at Ta=25°C

Parameter	Symbol	Values		Test Condition	Unit
Forward Voltage	V_F	Max.	7.5	$I_F = 350\text{mA}$	V
		Typ.	6.0		
		Min.	5.0		
Radiant Flux	Φ_e	Max.	-	$I_F = 350\text{mA}$	mW
		Typ.	72.0		
		Min.	56.0		
		Typ.	102.0	$I_F = 500\text{mA}$	
Peak Wavelength	W_P	Max	280	$I_F = 350\text{mA}$	nm
		Min	270		
Thermal Resistance (Junction-solders)	$R_{th\ j-s}$	Typ.	12.3	$I_F = 350\text{mA}$	K/W
Viewing Angle	$2\theta_{1/2}$	Typ.	120	$I_F = 350\text{mA}$	°
Electrostatic discharge (ESD)	-	Min.	2000	JESD22-A114-B	V

Notes:

1. Radiant flux (Φ_e) is the total Radiant flux output as measured with an integrating sphere.
2. Forward voltage (V_f) measurement tolerance is $\pm 0.1\text{V}$
3. Peak Wavelength measurement tolerance is $\pm 3\text{nm}$
4. Forward Radiant Flux measurement tolerance is $\pm 10\%$
5. The thermal resistance is defined as the figure. $R_{th\ j-s}$ is the thermal resistance from chip junction to solder.

Reference for thermal resistance: Using 2.0x2.0x0.17cm aluminum MCPCB

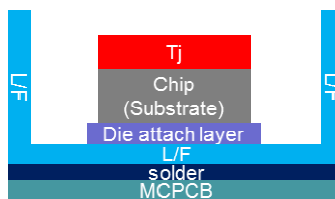

Specific Lighting LTPL-G35UV275UZ

5. Bin Code List

V_F : Forward Voltage Spec. Table		
V_F Bin	V_F (V) @ $I_F = 350\text{mA}$	
	Min.	Max.
V0	5.0	5.5
V1	5.5	6.0
V2	6.0	6.5
V3	6.5	7.0
V4	7.0	7.5

Tolerance on each Forward Voltage bin is +/- 0.1V

Φ_e : Radiant Flux Spec. Table		
Φ_e Bin	Φ_e (mW) @ $I_F = 350\text{mA}$	
	Min.	Max.
X1	56	66
X2	66	76
X3	76	86
X4	86	-

Tolerance on each Radiant Flux bin is +/- 10%

W_P : Peak Wavelength Spec table		
W_P Bin	W_P (nm) @ $I_F = 350\text{mA}$	
	Min.	Max.
W1	270	280

Tolerance on each Peak Wavelength bin is +/- 3nm

Notes:

Bin classification code is marked on each packing bag.

**Specific Lighting
LTPL-G35UV275UZ**

**6. Typical Electrical / Optical Characteristics Curves
(25°C Ambient Temperature Unless Otherwise Noted)**

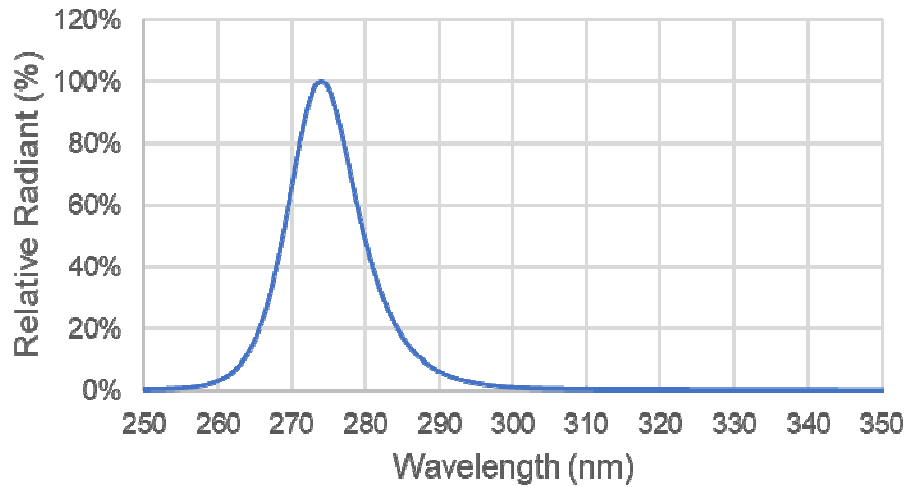

Fig 1. Relative Spectral Distribution

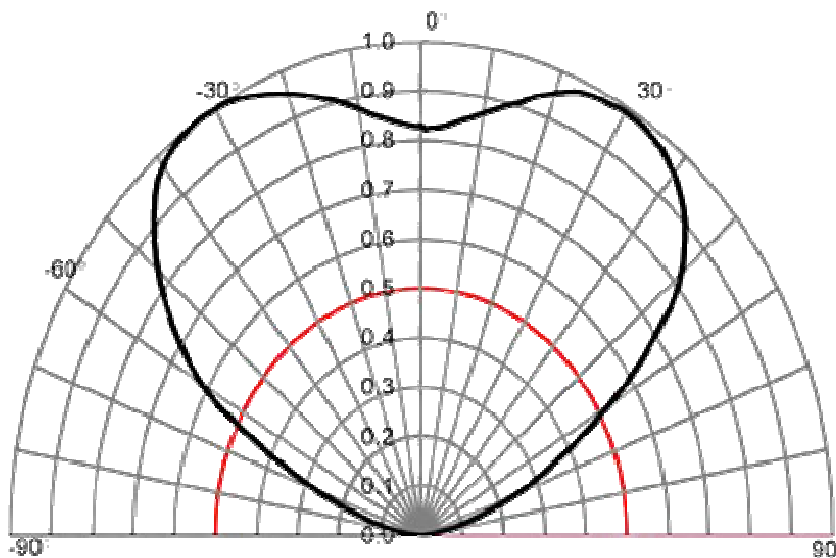

Fig 2. Radiation Characteristics

**Specific Lighting
LTPL-G35UV275UZ**

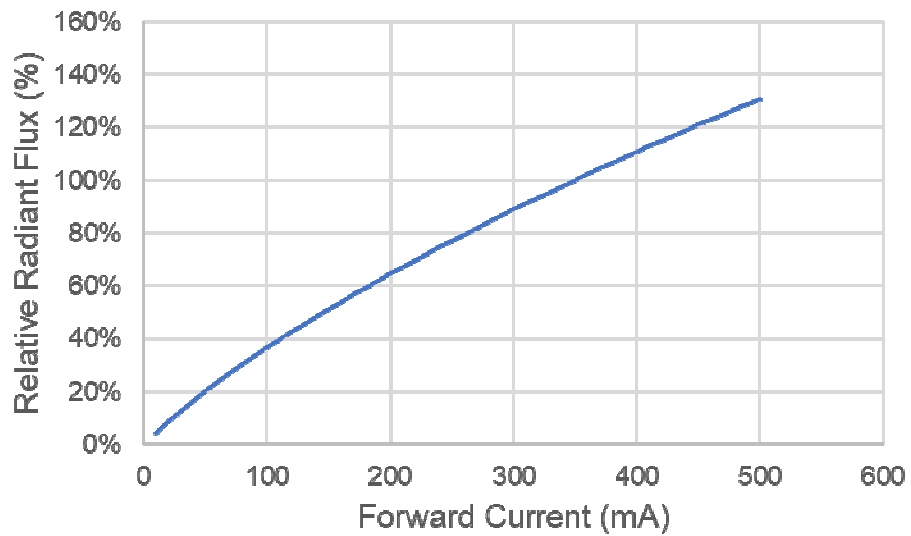

Fig 3. Relative Radiant Flux vs. Forward Current

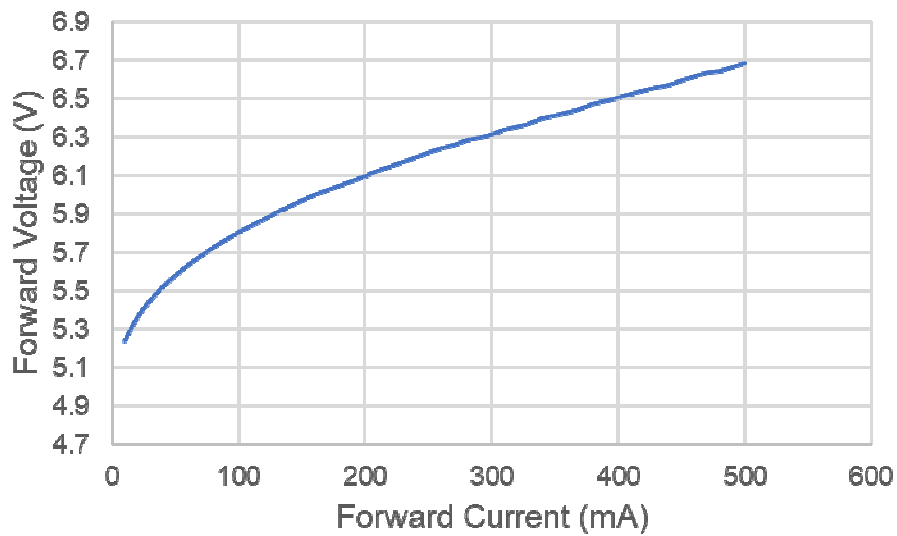

Fig 4. Forward Voltage vs. Forward Current

Specific Lighting LTPL-G35UV275UZ

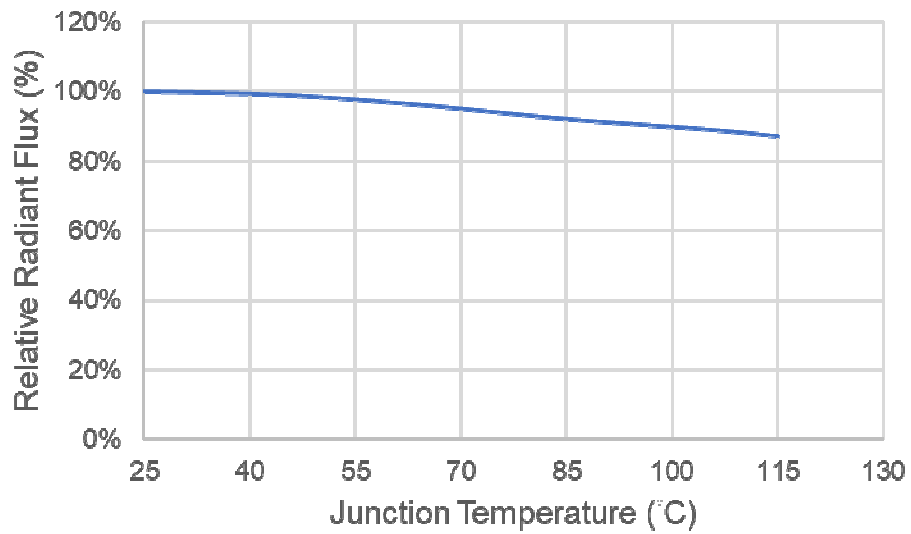

Fig 5. Relative Radiant Flux vs Junction Temperature

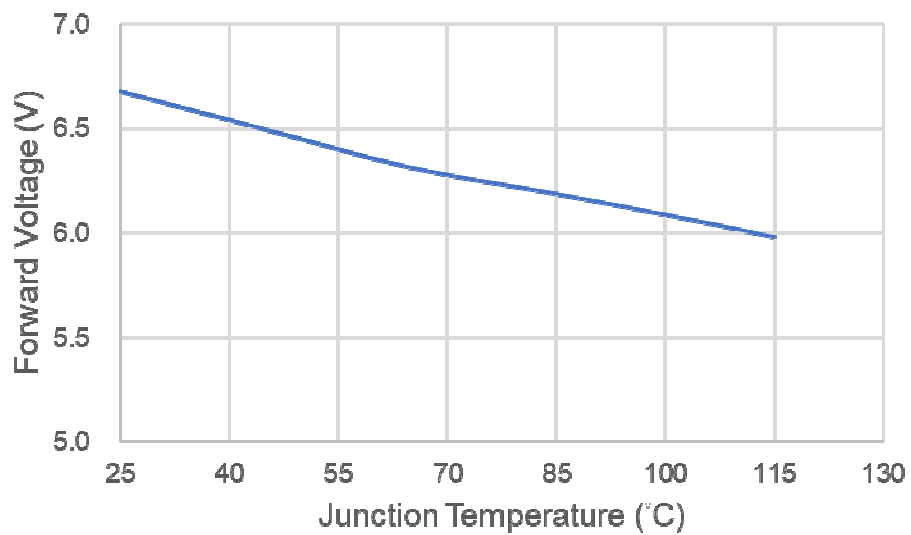

Fig 6. Forward Voltage vs Junction Temperature

**Specific Lighting
LTPL-G35UV275UZ**

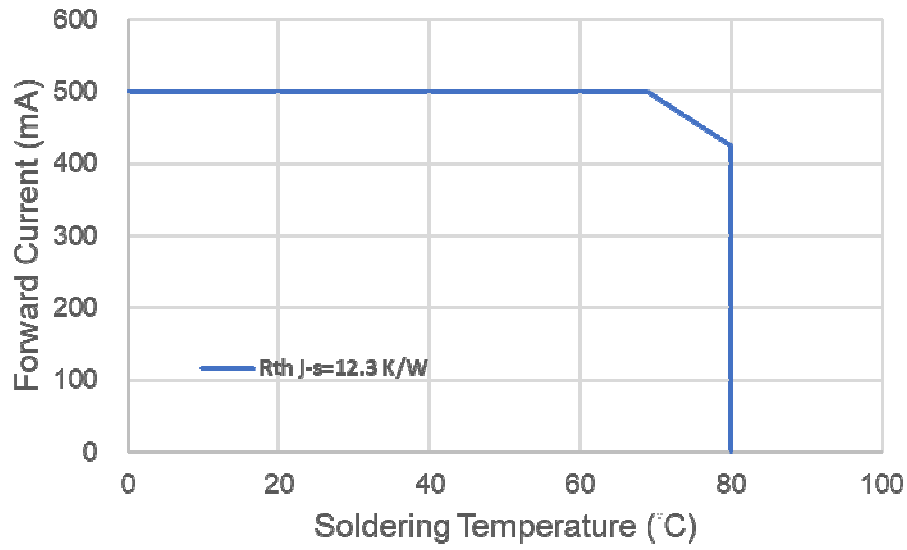

Fig 7. Forward Current Derating Curve

Specific Lighting LTPL-G35UV275UZ

7. Reliability Test Plan

7.1 Reliability Test Condition

No	Test item	Condition	Duration
1	Room Temperature Operating Life (RTOL)	Ta = 25°C, I _F =350mA	1,000 hrs
2	Room Temperature Operating Life (RTOL)	Ta = 25°C, I _F =500mA	1,000 hrs
3	High Temperature Storage Life (HTSL)	Ta = 100°C	1,000 hrs
4	Low Temperature Storage Life (LTSL)	Ta = -40°C	1,000 hrs
5	High Temperature & Humidity Storage (WHTSL)	Ta = 60°C, RH = 90%	1,000 hrs
6	Non-Operating Thermal Shock (TS)	-30°C (30min) ~ 85 °C (30min)	100 cycles

Notes:

Operating life test are mounted on 115x95x40 mm metal thermal heat sink

7.2 Criteria for Judging the Damage

Item	Symbol	Test Condition	Criteria for Judgment	
			Min.	Max.
Forward Voltage	V _F	I _F = 350mA	-	10%
Radiant Flux	Φ _e	I _F = 350mA	50%	-

Specific Lighting LTPL-G35UV275UZ

8. User Guide

8.1 Suggested Reflow Soldering Characteristics

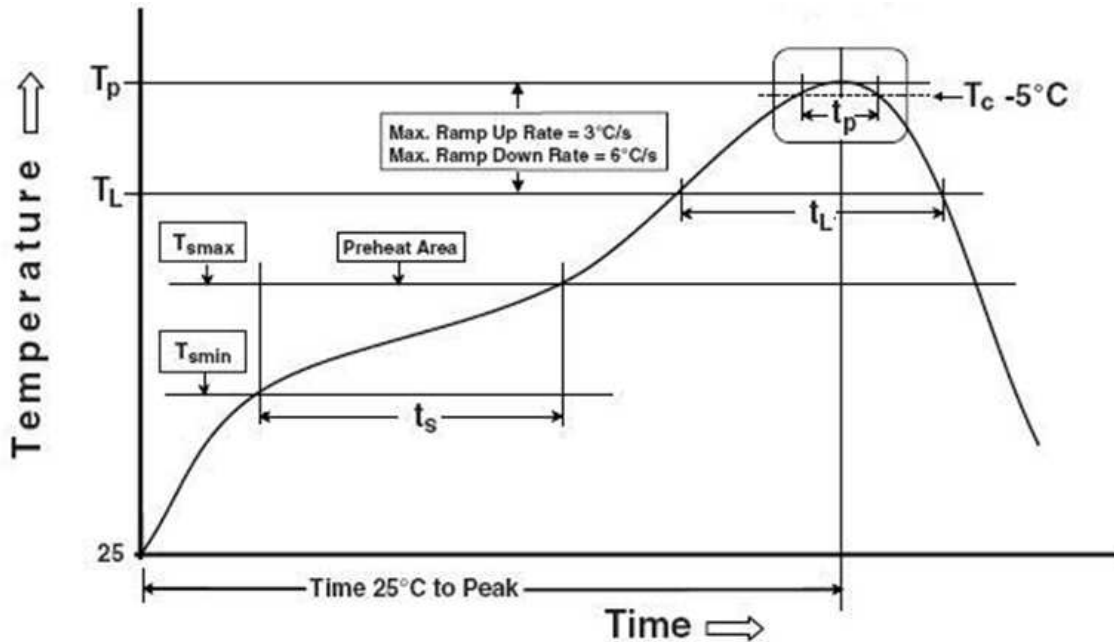

Profile Feature	Lead Free Assembly
Average Ramp-Up Rate (T_L to T_P)	$3^\circ\text{C} / \text{second max}$
Preheat Temperature Min (T_{Smin})	150°C
Preheat Temperature Max (T_{Smax})	200°C
Preheat Time (t_s)	60 – 120 seconds
Time Maintained Above Temperature (T_L)	217°C
Time Maintained Above Time (t_L)	60 – 150 seconds
Peak / Classification Temperature (T_P)	260°C^*
Time Within 5°C of Actual Peak Temperature (t_P)	10~30 seconds
Ramp – Down Rate (T_P to T_L)	$6^\circ\text{C} / \text{second max}$
Time 25°C to Peak Temperature	8 minutes max

The recommended peak temperature is 245°C . The maximum soldering temperature should be controlled under 260°C

Specific Lighting LTPL-G35UV275UZ

8.2 Recommend Printed Circuit Board Attachment Pad

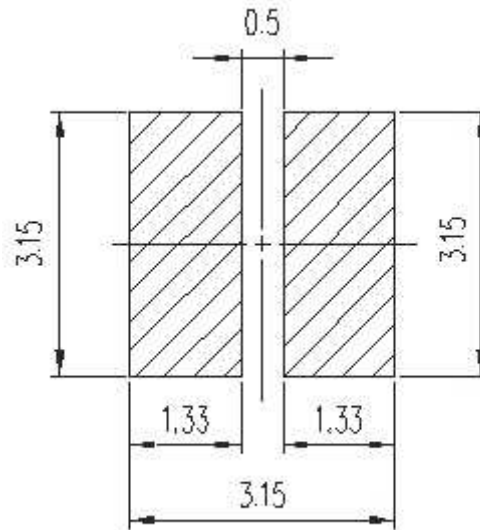

Notes:

1. The LEDs can be soldered using the reflow soldering or hand soldering method. The recommended hand soldering condition is 300°C max and 2secs max, only once, and the operation of reflow soldering is only up to three times at maximum.
2. All temperatures refer to topside of the package, measured on the package body surface.
3. The soldering profile could be further referred to different soldering grease material characteristic. The grease vendor will provide this information.
4. A rapid-rate process is not recommended for the LEDs cooling down from the peak temperature.
5. Although the recommended reflow conditions are specified above, the reflow or hand soldering condition at the lowest possible temperature is desirable for the LEDs.
6. LiteOn cannot make a guarantee on the LEDs which have been already assembled using the dip soldering method.
7. Recommend printed circuit board attachment pad specification tolerance ± 0.1 mm.

Specific Lighting LTPL-G35UV275UZ

8.3 Package Dimensions of Tape

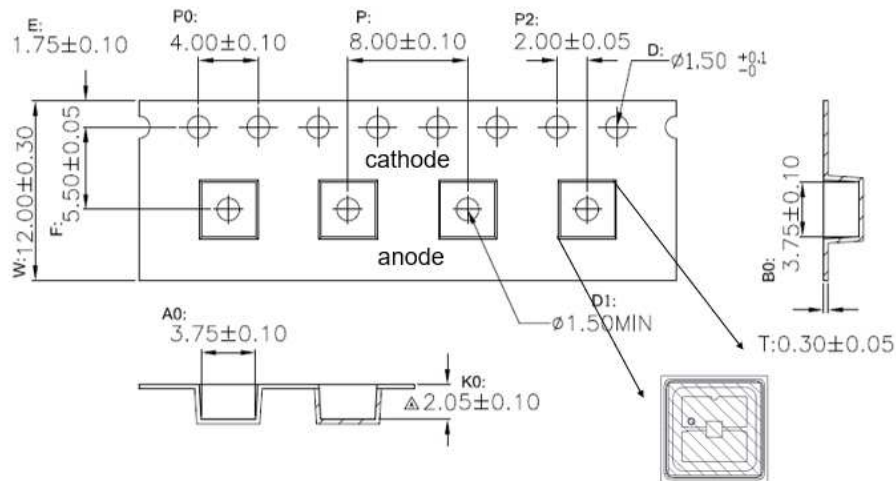

8.4 Package Dimensions of Reel

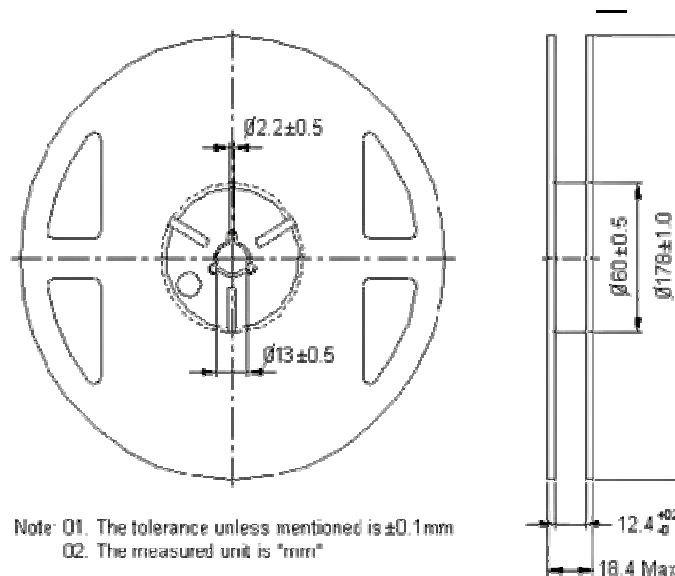

Notes:

1. Empty component pockets sealed with top cover tape.
2. 7 inch reel-maximum 500 pieces per reel. (Min. packing quantities are 100 pieces for remainders)
3. The maximum number of consecutive missing lamps is two.
4. In accordance with EIA-481-1-B specifications.

Specific Lighting LTPL-G35UV275UZ

9. Caution

9.1 Cleaning

Use alcohol-based cleaning solvents such as isopropyl alcohol to clean the LED if necessary.

Do not use unspecified chemical liquid to clean LED, it could harm the package.

9.2 Drive Method

An LED is a current-operated device. In order to ensure intensity uniformity on multiple LEDs connected in parallel in an application, it is recommended that a current limiting resistor be incorporated in the drive circuit, in series with each LED as shown in Circuit below.

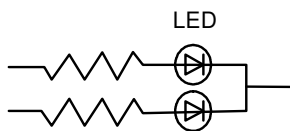

Circuit model A

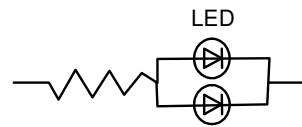

Circuit model B

(A) Recommended circuit.

(B) The brightness of each LED might appear different due to the differences in the I-V characteristics of those LEDs.

(C) This LED should be used under forward current, particularly not used under continuous reverse current to avoid the damage to LED.

The electrode pads are plated with gold, but it is still not recommended to the use under any of the following conditions, please confirm the performance and reliability are well enough if you use it under any of the following conditions

- Do not use sulfur-containing materials in commercial products including the materials such as seals and adhesives that may contain sulfur.
- Do not put this product in a place with a lot of moisture (over 85% relative humidity), dew condensation, briny air, and corrosive gas (Cl, H₂S, NH₃, SO₂, NO_x, etc.).

9.3 Manual Handling Remark

The LED should only be picked up by making contact with the sides of the LED body. It should not put any pressure on the lens either by finger or any hand tool. Do not puncture or push the lens.

Specific Lighting LTPL-G35UV275UZ

9.4 ESD (Electrostatic Discharge)

Static Electricity or power surge will damage the LED. Suggestions to prevent ESD damage:

- Use a conductive wrist band or anti-electrostatic glove when handling these LEDs.
- All devices, equipment, and machinery must be properly grounded.
- Work tables, storage racks, etc. Should be properly grounded.
- Use ion blower to neutralize the static charge which might have built up on surface of the LED's plastic lens as a result of friction between LEDs during storage and handling.

ESD-damaged LEDs will exhibit abnormal characteristics such as high reverse leakage current, low forward voltage, or “no light up” at low currents. To verify for ESD damage, check for “light up” and VF of the suspect LEDs at low currents.

Training and Certification

1. Working area is ESD-certified.
2. Training records and re-certification dates monitored.

Static-Safe Workstation & Work Areas

1. Static-safe working stations or work-areas have ESD signs.
2. All surfaces and objects at all static-safe workstation and within 1 ft measure less than 100V.
3. All ionizer activated, positioned towards the units.
4. Each work surface mats grounding is good.

Personnel Grounding

1. Every person (including visitors) handling ESD sensitive (ESDS) items wear wrist strap, heel strap or conductive shoes with conductive flooring
2. If conductive footwear used, conductive flooring also present.
3. Garments, hairs or anything closer than 1 ft to ESD items measure less than 100V.
4. The wrist strap or heel strap/conductive shoes are checked daily and result recorded.
5. All wrist strap or heel strap checkers calibration up to date.

Device Handling

1. Each ESDS items identified by EIA-471 labels on item or packaging.
2. No static charge generators (e.g. plastics) inside shielding containers with ESDS items.
3. All flexible conductive and dissipative package materials are inspected before reuse or recycles

Specific Lighting LTPL-G35UV275UZ

9.5 Storage

This product is qualified as Moisture sensitive Level 3 per JEDEC J-STD-020 Precaution when handling this moisture sensitive product is important to ensure the reliability of the product.

The package is sealed:

The LEDs should be stored at 30°C or less and 85%RH or less. And the LEDs are limited to use within one year, while the LEDs is packed in moisture-proof package with the desiccants inside.

The package is opened:

The LEDs should be stored at 30°C or less and 60%RH or less. The LEDs are limited to solder process within 168hrs.

If the Humidity Indicator shows the pink color in 10% even higher or exceed the storage limiting time since opened, we recommended to baking LEDs at 60°C at least 24hours before solder. To seal the remainder LEDs return to package, it's recommended to be with workable desiccants in original package.

9.6 Safety

DO NOT directly look at the UV light from LED or optical instrument because it is harmful to human eyes.

And it is recommended to use UV goggles protective glasses for avoiding eye damage.

Specific Lighting
LTPL-G35UV275UZ

10. Datasheet Version

Version	Date	Owner	Change Item
-	2023/04/13	Marco Chen	Initial specification