



Specific Lighting Product Data Sheet LTPL-W35UV275GH

Spec No. :DS23-2021-0035
Effective Date: 09/29/2021
Revision: A

LITE-ON DCC

RELEASE

Specific Lighting LTPL-W35UV275GH

1. Description

The LiteON LTPL-W35 UV product series is a revolutionary, energy efficient light source for sterilization and medical application, combining the lifetime and reliability advantages of Light Emitting Diodes with the brightness of conventional light source. It gives you design freedom, and creating a new opportunities for solid state UVC light source to displace conventional UV technologies.

Features

- I.C. compatible
- RoHS compliant and Pb free
- Lower operating costs
- Reduced maintenance costs

2. Outline Dimensions

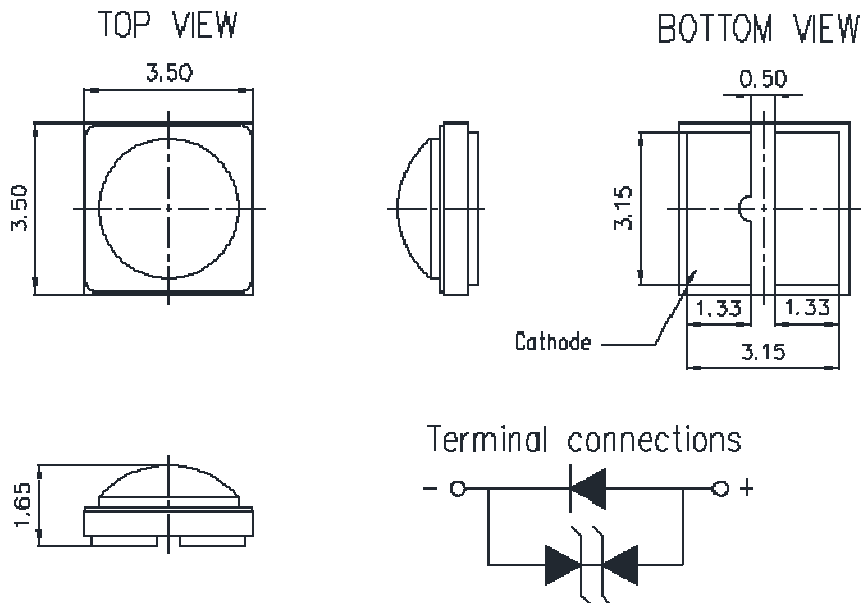

Notes:

All dimensions are in millimeters and tolerance is $\pm 0.2\text{mm}$ unless otherwise noted.

Specific Lighting LTPL-W35UV275GH

3. Absolute Maximum Ratings at Ta=25°C

Parameter	Symbol	Rating	Unit
Power Dissipation	P _o	5.3	W
DC Forward Current	I _F	700	mA
Operating Temperature Range	T _{opr}	-40~+80	°C
Storage Temperature Range	T _{stg}	-40~+100	°C
Junction Temperature	T _j	110	°C

Notes:

Operating the LED under reverse bias condition long time might result in damage or failure of the component.

Specific Lighting LTPL-W35UV275GH

4. Electro-Optical Characteristics at Ta=25°C

Parameter	Symbol	Values		Test Condition	Unit
Forward Voltage	V_F	Max.	7.5	$I_F = 600\text{mA}$	V
		Typ.	6.7		
		Min.	6.0		
Radiant Flux	Φ_e	Typ.	165	$I_F = 700\text{mA}$	mW
		Max.	-	$I_F = 600\text{mA}$	
		Typ.	150		
		Min.	120		
		Typ.	100	$I_F = 350\text{mA}$	
Peak Wavelength	W_p	Max	280	$I_F = 600\text{mA}$	nm
		Min	265		
Thermal Resistance (Junction-Solder)	$R_{th\ j-s}$	Typ.	10.5	$I_F = 600\text{mA}$	K/W
Viewing Angle	$2\theta_{1/2}$	Typ.	160	$I_F = 600\text{mA}$	°
Electrostatic discharge (ESD)	-	Max	2000	JESD22-A114-B	V

Notes:

1. Radiant flux (Φ_e) is the total Radiant flux output as measured with an integrating sphere.
2. Forward voltage (V_f) measurement tolerance is $\pm 0.1\text{V}$
3. Peak Wavelength measurement tolerance is $\pm 3\text{nm}$
4. Forward Radiant Flux measurement tolerance is $\pm 10\%$
5. The thermal resistance is defined as the figure. $R_{th\ j-s}$ is the thermal resistance from chip junction to solder.
Reference for R_{th} : Using 20x20x1.7mm aluminum MCPCB, and mounted on 115x95x40mm fin heatsink.

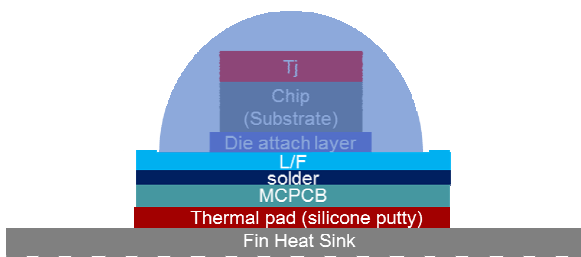

Specific Lighting LTPL-W35UV275GH

5. Bin Code list

V _F Forward Voltage Spec. Table		
V _F Bin	V _F (V) @ I _F = 600mA	
	Min.	Max.
V1	6.0	6.5
V2	6.5	7.0
V3	7.0	7.5

Tolerance on each Forward Voltage bin is +/- 0.1V

Φ _e Radiant Flux Spec. Table		
Φ _e Bin	Φ _e (mW) @ I _F = 600mA	
	Min.	Max.
X2	120	140
X3	140	160
X4	160	-

Tolerance on each Radiant Flux bin is +/- 7%

W _p : Peak Wavelength Spec table		
W _p Bin	W _p (nm) @ I _F = 600mA	
	Min.	Max.
W1	265	280

Tolerance on each Peak Wavelength bin is +/- 3nm

Notes:

Bin classification code is marked on each packing bag.

**Specific Lighting
LTPL-W35UV275GH**

6. Typical Electrical / Optical Characteristics Curves

(25°C Ambient Temperature Unless Otherwise Noted)

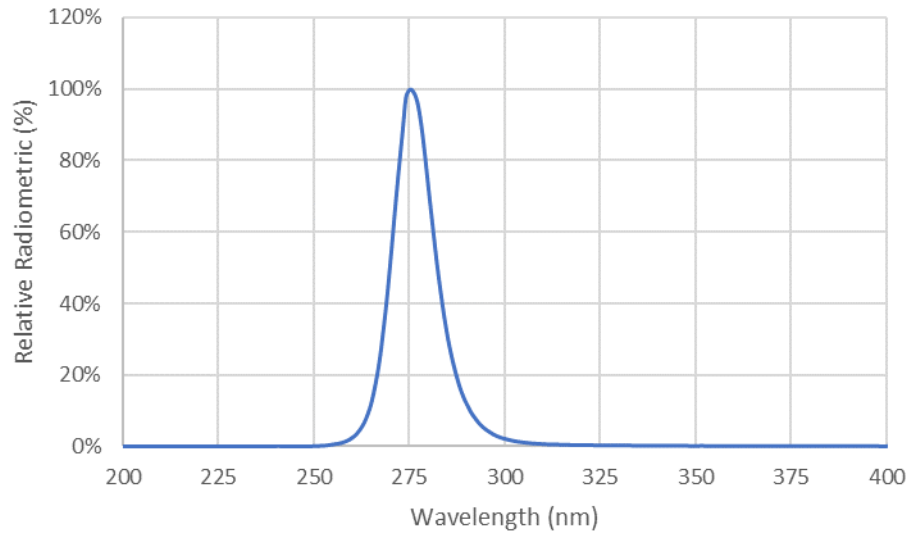

Fig 1. Relative Spectral Distribution

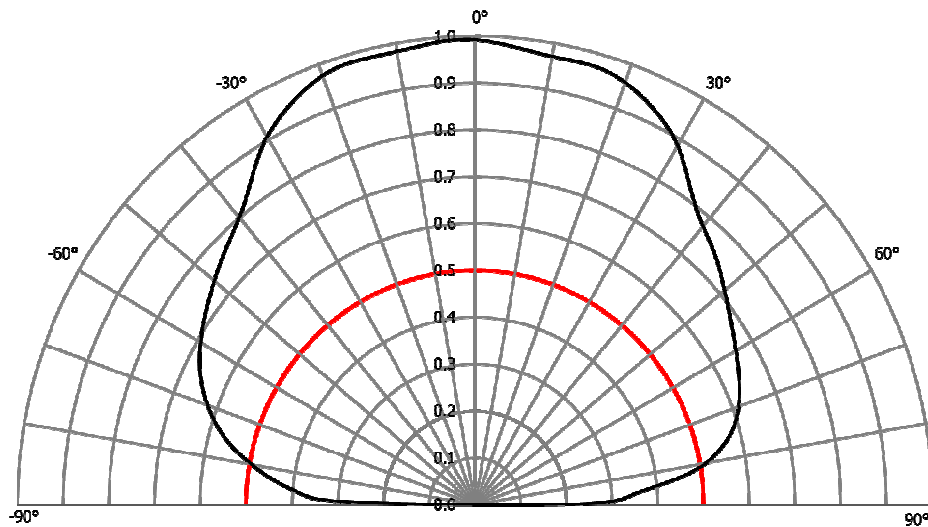

Fig 2. Radiation Characteristics

Specific Lighting LTPL-W35UV275GH

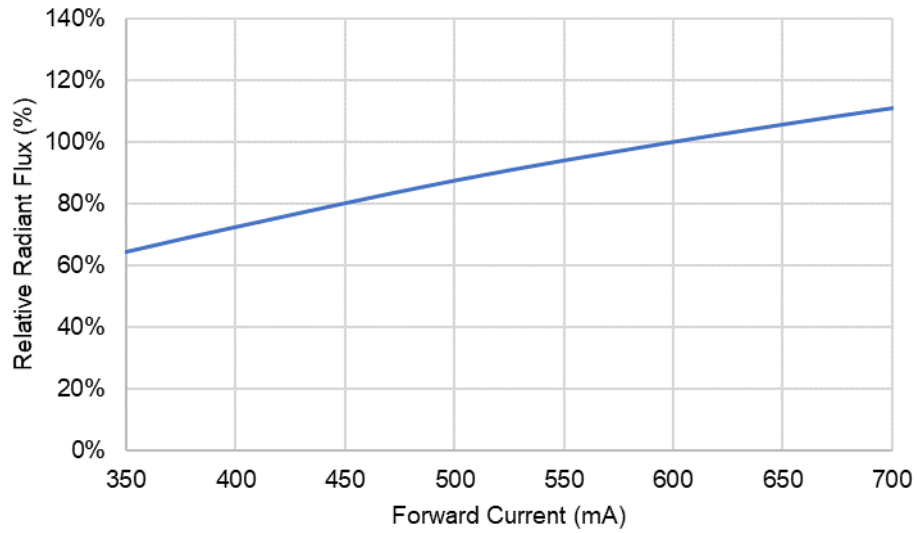

Fig 3. Relative Radiant Flux vs. Forward Current

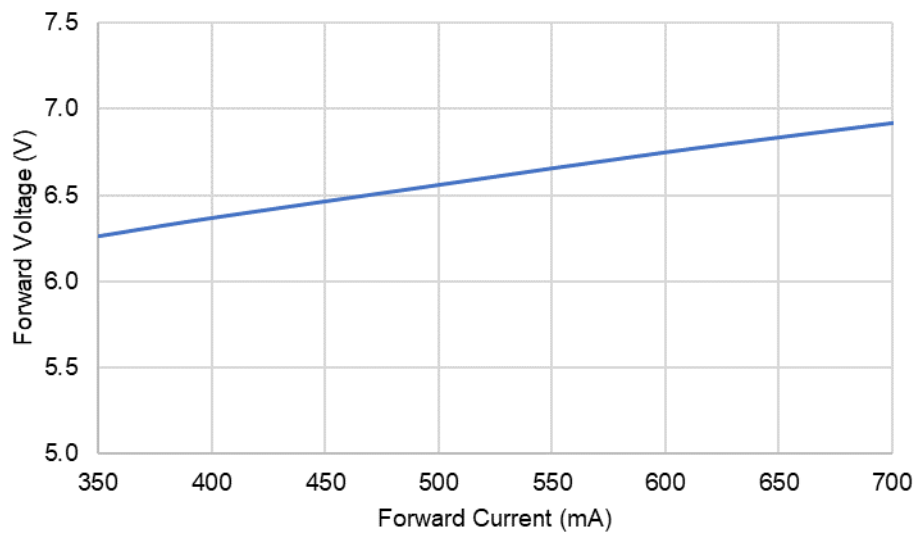

Fig 4. Forward Voltage vs. Forward Current

Specific Lighting LTPL-W35UV275GH

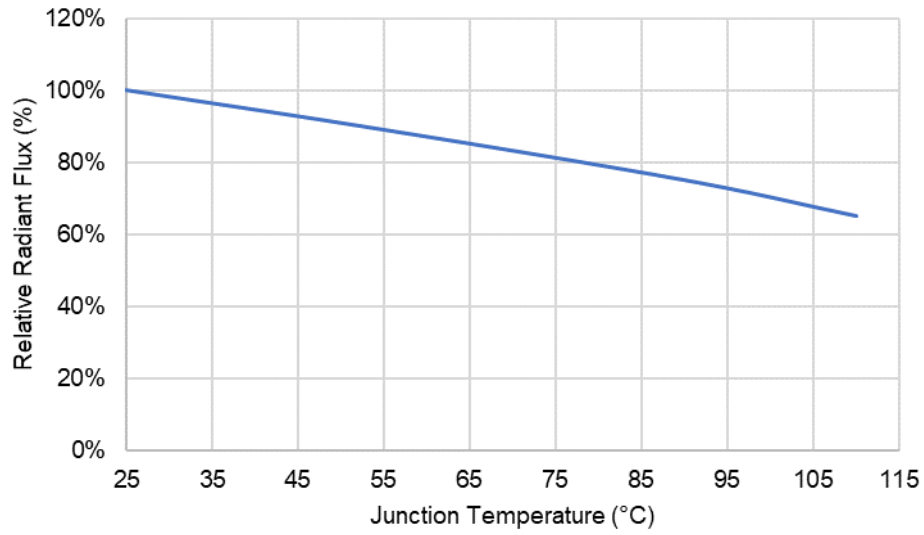

Fig.5 Relative Radiant Flux vs Junction Temperature

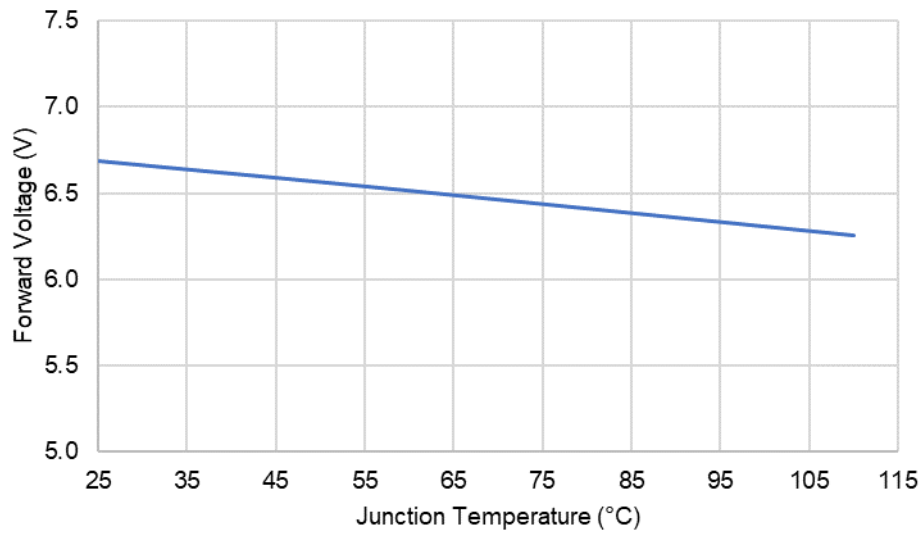

Fig 6. Forward Voltage vs Junction Temperature

Specific Lighting LTPL-W35UV275GH

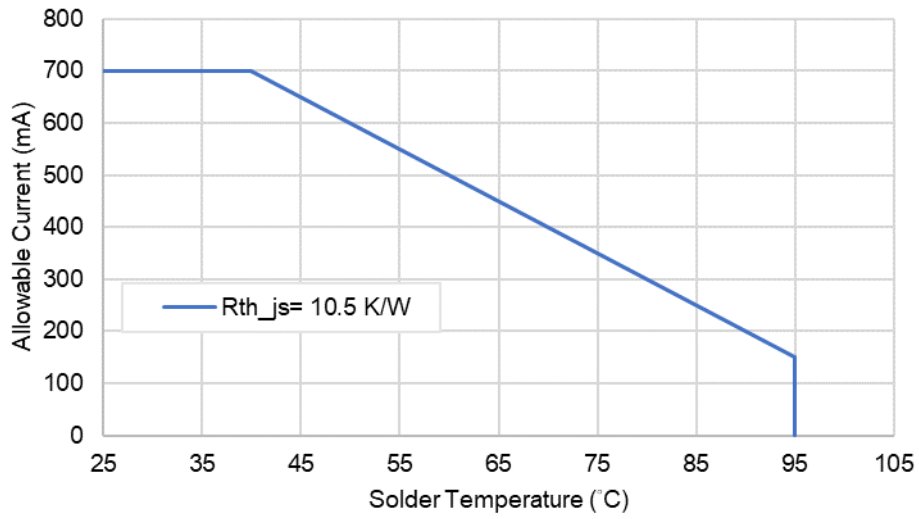

Fig 7. Forward Current Derating Curve

Specific Lighting LTPL-W35UV275GH

7. Reliability Test Plan

7.1 Reliability Test Condition

No	Test item	Condition	Duration
1	Room Temperature Operating Life (RTOL)	$T_a = 25^\circ\text{C}$, $I_F=350\text{mA}$	3,000 hrs
2	Room Temperature Operating Life (RTOL)	$T_a = 25^\circ\text{C}$, $I_F=600\text{mA}$	1,000 hrs
3	Room Temperature Operating Life (RTOL)	$T_a = 25^\circ\text{C}$, $I_F=700\text{mA}$	1,000 hrs
4	High Temperature Operating Life (HTOL)	$T_s = 95^\circ\text{C}$, $I_F=150\text{mA}$	1,000 hrs
5	Low Temperature Operating Life (LTOL)	$T_a = -40^\circ\text{C}$, $I_F=350\text{mA}$	1,000 hrs
6	High Temperature & Humidity Operating Life (WHTOL)	$T_a = 60^\circ\text{C}$, $\text{RH} = 90\%$ $I_F=250\text{mA}$	500 hrs
7	High Temperature Storage (HTS)	$T_a = 100^\circ\text{C}$	1,000 hrs
8	Low Temperature Storage (LTS)	$T_a = -40^\circ\text{C}$	1,000 hrs
9	High Temperature & Humidity Storage (WHTS)	$T_a = 60^\circ\text{C}$, $\text{RH} = 90\%$	1,000 hrs
10	Non-Operating Thermal Shock (TS)	-30°C (30min) ~ 85°C (30min)	100 cycles

Notes:

Operating life test are mounted on 115x95x40 mm metal heat sink

7.2 Criteria for Judging the Damage

Item	Symbol	Test Condition	Criteria for Judgment	
			Min.	Max.
Forward Voltage	V_F	$I_F=600\text{mA}$	-	10%
Radiant Flux	Φ_e	$I_F=600\text{mA}$	50%	-
Peak Wavelength	W_p	$I_F=600\text{mA}$	-2nm	+2nm

Specific Lighting LTPL-W35UV275GH

8. User Guide

8.1 Suggested Reflow Soldering Characteristics

(Low temperature SMT is recommended)

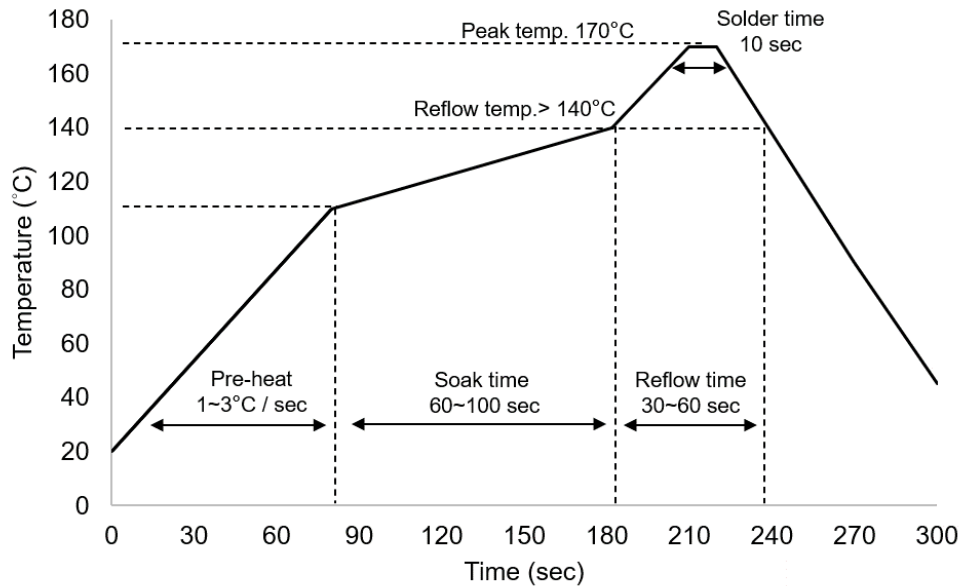

Profile Feature	Lead Free Assembly
Pre-heat Rate (Ramp to Soak)	1~3°C / sec
Soak Temperature Min	110°C
Soak Temperature Max	140°C
Soak Time	60~100 sec
Reflow Temperature Min	140°C
Reflow time	30~60 sec
Peak / Classification Temperature	170°C
Solder time	10 sec max

Notes:

1. Recommended Bi-based solder paste which melting temperature is lower than 140°C.
2. Peak temperature MUST be controlled under 170°C and max time duration 10sec.
3. Do not use hot plate or soldering iron to solder LEDs instead of reflow process.
4. The PKG can only be done the reflow once.

Specific Lighting LTPL-W35UV275GH

8.2 Recommend Printed Circuit Board Attachment Pad

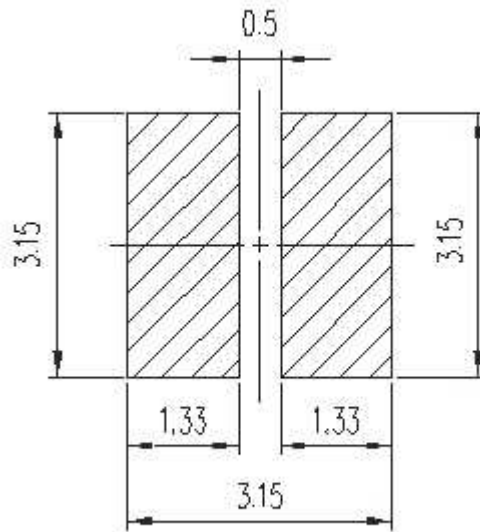

Notes:

1. All temperatures refer to topside of the package, measured on the package body surface.
2. The soldering profile could be further referred to different soldering grease material characteristic. The grease vendor will provide this information.
3. A rapid-rate process is not recommended for the LEDs cooling down from the peak temperature.
4. Although the recommended reflow conditions are specified above, the reflow condition at the lowest possible temperature is desirable for the LEDs.
5. LITEON cannot make a guarantee on the LEDs which have been already assembled using the dip soldering method.
6. Recommend printed circuit board attachment pad specification tolerance ± 0.1 mm.

Specific Lighting LTPL-W35UV275GH

8.3 Package Dimensions of Tape

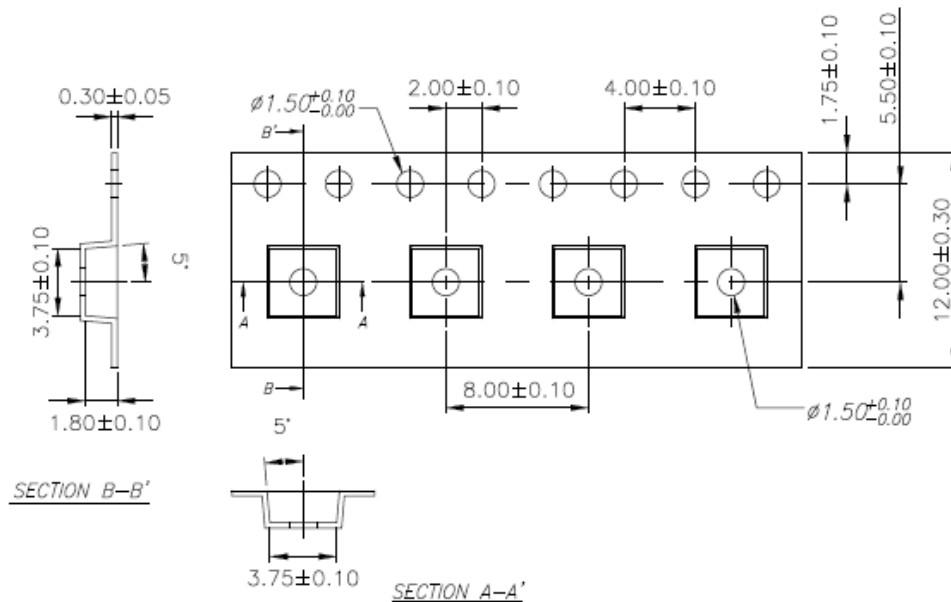

8.4 Package Dimensions of Reel

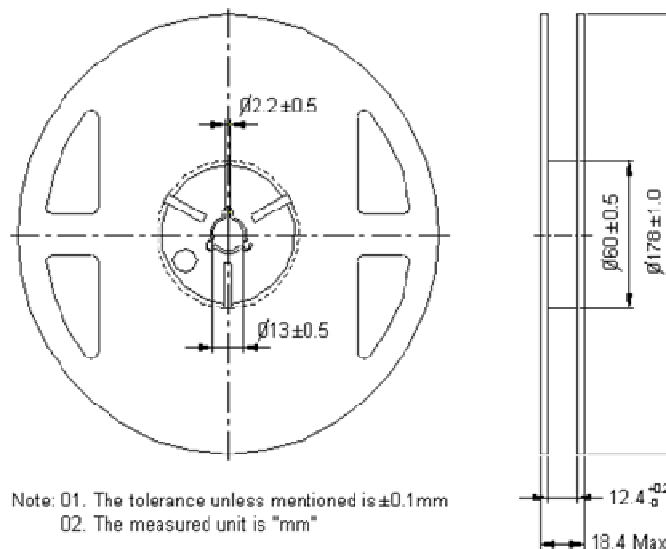

Notes:

1. Empty component pockets sealed with top cover tape.
2. 7 inch reel-maximum 500 pieces per reel. (Min. packing quantities are 100 pieces for remainders)
3. The maximum number of consecutive missing lamps is two.
4. In accordance with EIA-481-1-B specifications.

Specific Lighting LTPL-W35UV275GH

9. Caution

Cleaning

Use alcohol-based cleaning solvents such as isopropyl alcohol to clean the LED if necessary.
Do not use unspecified chemical liquid to clean LED, it could harm the package.

Drive Method

An LED is a current-operated device. In order to ensure intensity uniformity on multiple LEDs connected in parallel in an application, it is recommended that a current limiting resistor be incorporated in the drive circuit, in series with each LED as shown in Circuit below.

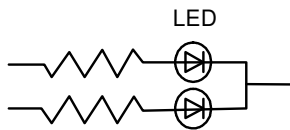

Circuit model A

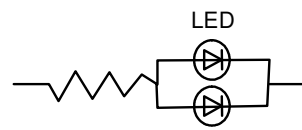

Circuit model B

(A) Recommended circuit.

(B) The brightness of each LED might appear different due to the differences in the I-V characteristics of those LEDs.

(C) This LED should be used under forward current, particularly not used under continuous reverse current to avoid the damage to LED.

The electrode pads are plated with gold, but it is still not recommended to the use under any of the following conditions, please confirm the performance and reliability are well enough if you use it under any of the following conditions

- Do not use sulfur-containing materials in commercial products including the materials such as seals and adhesives that may contain sulfur.
- Do not put this product in a place with a lot of moisture (over 85% relative humidity), dew condensation, briny air, and corrosive gas (Cl, H₂S, NH₃, SO₂, NO_x, etc.).

Manual Handling Remark

The LED should only be picked up by making contact with the sides of the LED body. It should not put any pressure on the lens either by finger or any hand tool. Do not puncture or push the lens.

Specific Lighting LTPL-W35UV275GH

ESD (Electrostatic Discharge)

Static Electricity or power surge will damage the LED. Suggestions to prevent ESD damage:

- Use a conductive wrist band or anti-electrostatic glove when handling these LEDs.
- All devices, equipment, and machinery must be properly grounded.
- Work tables, storage racks, etc. Should be properly grounded.
- Use ion blower to neutralize the static charge which might have built up on surface of the

LED's plastic lens as a result of friction between LEDs during storage and handling.

ESD-damaged LEDs will exhibit abnormal characteristics such as high reverse leakage current, low forward voltage, or "no light up" at low currents. To verify for ESD damage, check for "light up" and V_F of the suspect LEDs at low currents.

Training and Certification

1. Working area is ESD-certified.
2. Training records and re-certification dates monitored.

Static-Safe Workstation & Work Areas

1. Static-safe working stations or work-areas have ESD signs.
2. All surfaces and objects at all static-safe workstation and within 1 ft measure less than 100V.
3. All ionizer activated, positioned towards the units.
4. Each work surface mats grounding is good.

Personnel Grounding

1. Every person (including visitors) handling ESD sensitive (ESDS) items wear wrist strap, heel strap or conductive shoes with conductive flooring.
2. If conductive footwear used, conductive flooring also present.
3. Garments, hairs or anything closer than 1 ft to ESD items measure less than 100V.
4. The wrist strap or heel strap/conductive shoes are checked daily and result recorded.
5. All wrist strap or heel strap checkers calibration up to date.

Device Handling

1. Each ESDS items identified by EIA-471 labels on item or packaging.
2. No static charge generators (e.g. plastics) inside shielding containers with ESDS items.
3. All flexible conductive and dissipative package materials are inspected before reuse or recycles

Specific Lighting LTPL-W35UV275GH

Storage

When the package is sealed,

The LEDs should be stored at 5°C~30°C and 60%RH or less. And the LEDs are limited to use within 12 months, while the LEDs is packed in moisture-proof package with the desiccants inside.

When the package is opened,

The LEDs should be stored at 5°C~30°C and 60%RH or less. The LEDs are limited to solder process within 2 weeks. If the Humidity Indicator shows the pink color in 10% even higher or exceed the storage limiting time since opened, we recommended to baking LEDs at 60°C at least 24hours before solder. To seal the remainder LEDs return to package, it's recommended to be with workable desiccants in original package.

Safety

DO NOT directly look at the UV light from LED or optical instrument because it is harmful to human eyes. And it is recommended to use UV goggles protective glasses for avoiding eye damage.

**Specific Lighting
LTPL-W35UV275GH**

10. Datasheet Version

Version	Date	Owner	Change Item
-	2021/07/21	Charles Hsu	Initial specification
A	2021/09/22	ChunChieh Chang	Modify "Radiation Characteristics" fig. Page. 5