

Received 4 November 2020; revised 26 January 2021 and 21 February 2021; accepted 7 March 2021. Date of publication 15 March 2021; date of current version 26 March 2021. The review of this paper was arranged by Editor A. Nathan.

Digital Object Identifier 10.1109/JEDS.2021.3065905

AM PWM Driving Circuit for Mini-LED Backlight in Liquid Crystal Displays

CHIH-LUNG LIN^{1,2} (Member, IEEE), SUNG-CHUN CHEN¹, MING-YANG DENG¹, YUAN-HAO HO¹,
CHIEH-AN LIN¹, CHIA-LING TSAI¹, WEI-SHENG LIAO¹, CHIH-I LIU¹, CHIA-EN WU³, AND JIA-TIAN PENG³

¹ Department of Electrical Engineering, National Cheng Kung University, Tainan 701-01, Taiwan

² Advanced Optoelectronic Technology Center, National Cheng Kung University, Tainan 701-01, Taiwan

³ Circuit Design Department, AU Optronics Corporation, Hsinchu 30078, Taiwan

CORRESPONDING AUTHOR: C.-L. LIN (e-mail: cclin@ee.ncku.edu.tw)

This work was supported in part by the Advanced Optoelectronic Technology Center, National Cheng Kung University, Tainan, Taiwan; in part by the Ministry of Science and Technology of Taiwan under Project MOST 109-2622-E-006-019-CC2; and in part by the AU Optronics Corporation.

ABSTRACT This work proposes a mini-LED driving circuit that adopts the pulse-width modulation (PWM) driving method for use in a liquid-crystal display (LCD) backlight. The proposed circuit can compensate for the threshold voltage (V_{TH}) variation in a low-temperature poly-crystalline silicon thin-film transistor (LTPS TFT) and a VSS current-resistance (I-R) rise, to generate a stable driving current to power the mini-LED. Since the proposed circuit uses the PWM method, the mini-LED can be operated at the best luminance-efficacy point, minimizing the power consumption of the circuit. The electrical characteristic of fabricated LTPS TFTs are measured to establish a simulation model to demonstrate the feasibility of the proposed circuit. Simulation results demonstrate that the relative mini-LED current error rates are below 9% when the V_{TH} varies ± 0.3 V and VSS rises by 1 V. With respect to precise control of the gray level, the time shifts of current pulses are within 11.48 μ s over the whole grayscale. The improvement in the power consumption of the proposed circuit is more than 21% than that of a circuit that is driven by pulse amplitude modulation.

INDEX TERMS Active-matrix display, LCD backlight, high dynamic range, mini-LED, pulse-width modulation, power consumption, thin-film transistor.

I. INTRODUCTION

Since the micro light-emitting diode (micro-LED) is an inorganic and self-emitting device, the micro-LED direct-view display is expected to be the next-generation technology for its advantages such as high reliability, high resolution, and high contrast ratio [1]. However, the mass transfer issue reduces the processing yield of the micro-LED which leads to the higher cost of the micro-LED panel. Mini light-emitting diode (mini-LED) has some characteristics in common with the micro-LED such as high reliability and high luminance. Although the resolution of the mini-LED panel cannot reach to as high as micro-LED displays, such diodes have been used as a direct-lit backlight module in a liquid-crystal display (LCD). By utilizing multi-zone local dimming, an LCD with a mini-LED backlight

module can achieve a high dynamic range (HDR), favoring image quality. The two driving methods of mini-LED backlight are the active matrix (AM) and passive matrix (PM) driving methods. The AM driving method is preferred since one control IC can drive more mini-LEDs than the PM method, increasing the resolution of the backlight module [2]. Since the backlight transmittance of an LCD panel is typically less than 7% [3], the driving current of a mini-LED must be at the milliampere level to achieve enough light intensity. Hence, a low-temperature poly-crystalline silicon thin-film transistor (LTPS TFT) is used in AM methods to drive mini-LEDs owing to its high mobility and excellent current driving capability [4]–[6]. For example, the conventional 2T1C driving circuit has already been used in mini-LED backlight units in current LCD

products [7]. Nevertheless, the non-uniformity of the laser beaming energy in the excimer laser annealing (ELA) process causes threshold voltage (V_{TH}) variations of LTPS TFTs [8]–[10]. In addition, the voltage on the power line can be affected by the intrinsic parasitic resistance, leading to the power line current-resistance drop/rise (I-R rise/drop) phenomenon [11]–[13]. Consequently, the driving current is non-uniform, causing a severe image mura. Most active matrix organic light-emitting diode (AMOLED) pixel circuits that use the voltage programming method solve the aforementioned problems [14]–[18]. However, applying these circuits to a mini-LED may increase power consumption since the luminance efficiency is not linearly correlated with the driving current of the mini-LED. The circuit proposed by Kimura *et al.* using the pulse-width modulation (PWM) driving method can keep the driving current at the optimal luminous-efficacy point. In this method, the gray level is represented as emission time which is considered to be an effective way [19]. Nevertheless, to meet the demand for mini-LED backlights, the current in the circuit must be at the milliamper level, which is difficult to achieve. Kim *et al.* proposed another PWM driving circuit without a current source [20]. Although their circuit is more easily realizable, the rising and falling times must be reduced to less than the emission time of one gray level to achieve precise control of the gray levels.

This work proposes a new mini-LED backlight circuit whose power consumption is reduced by using the PWM driving method. The V_{TH} variations of LTPS TFTs and VSS I-R rises on the power lines are both compensated while the VDD I-R drop is not taken into the consideration as the gate-to-source voltage of the n-type driving TFT dominates the emission current of the mini-LED (see the detailed explanation in Appendix A). To further reduce the power consumption, only a single TFT is located in the driving current path, so the voltage across VDD and VSS can be shrunk. Results of simulations of a backlight panel with 48×48 dimming zones and a frame rate of 90 Hz indicate that the proposed circuit can compensate for V_{TH} and VSS. The precise control and power saving are verified, establishing the feasibility of the proposed circuit for use in a mini-LED backlight unit.

II. OPERATION

Fig. 1 shows schematic and related timing diagram of the proposed mini-LED driving circuit (see the circuit layout image in the Appendix B). T1 is the driving TFT that generates the driving current for the mini-LED. Notably, T1 and T2 have similar electrical characteristics since T1 is adjacent to T2 and both are designed with the same aspect ratio. T2 is used to compensate for the V_{TH} variation of T1 to avoid the placement of an excessive number of switching TFTs on the driving current path, reducing the total voltage across the proposed circuit. By the matching method (T1 and T2), the power consumption of the circuit can, thus be reduced. S1, S2, EM, and Vsweep signals drive the circuit;

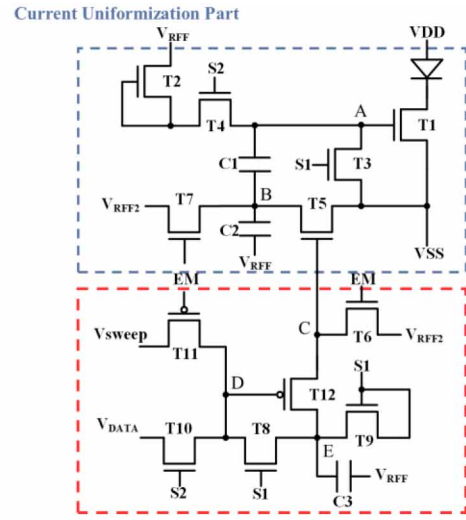

(a)

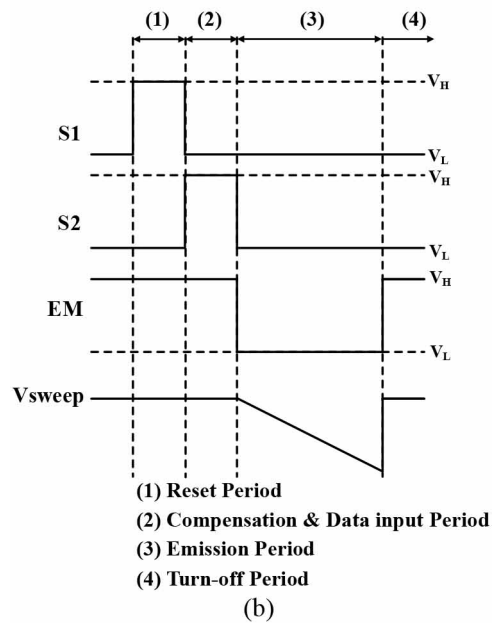

(b)

FIGURE 1. (a) Schematic and (b) timing diagram of proposed mini-LED driving circuit.

C1-C3 are the storage capacitors. Herein, Vsweep is a sawtooth wave-like signal. The operation of the proposed circuit is described as follows.

A. RESET PERIOD

S1 and EM go high to turn on T3, T6, T7, T8, and T9, while S2 goes low to turn off T4 and T10. Since the gate voltage of T1 (V_A) is reset to V_{SS} through T3, the turned off T1 ensures that no current flows through the mini-LED. Meanwhile, T7 and T6 respectively discharge node B (V_B) and node C (V_C) to V_{REF2} . Herein, the voltage of V_{REF2} is smaller than V_{SS}, so T5 is not activated in this period. With respect to PWM control, node D (V_D) and node E (V_E) are charged to V_H to turn off T12.

B. COMPENSATION & DATA INPUT PERIOD

In this period, S1 turns low and S2 turns high. Hence, T4 and T10 are turned on, while T3, T8, and T9 are turned off. The diode-connected T2 discharges node A to $V_{REF} + V_{TH_T2}$ where V_{TH_T2} is the threshold voltage of T2. The voltage that is stored in the capacitor (C1) is given by the following equation.

$$V_{C1} = V_{REF} + V_{TH_T2} - V_{REF2} \quad (1)$$

Since T12 is the TFT that determines the emission time of the mini-LED, the variation in electrical characteristic of T12 shifts the emission time, generating non-uniform brightness. To compensate for the V_{TH} variation of T12, T12 forms a source follower structure to discharge node E through T6 and T12 until V_E becomes $V_{DATA} + |V_{TH_T12}|$. Thus, the V_{TH} of T12 can be sensed and stored at node E. Herein, node D (V_D) will be input to the corresponding V_{DATA} through T10 to provide the required gray level of the backlight.

C. EMISSION PERIOD

In the beginning of this period, all TFTs are turned off except for T11 and the voltage from the sweep signal line transmits V_{SWEEP} to node D. Since V_{sweep} is a sawtooth wave, V_D gradually decreases during the emission period and activates T12 whenever the following condition holds.

$$\begin{aligned} V_{SG} = V_E - V_D &> |V_{TH_T12}| \\ (V_{DATA} + |V_{TH_T12}|) - V_{SWEEP} &> |V_{TH_T12}| \\ V_{DATA} &> V_{SWEEP} \end{aligned} \quad (2)$$

According to Eq. (2), since the V_{TH} of T12 is stored at node E, the emission time of the mini-LED that is controlled by T12 is independent of the variation of the TFT. When T12 is turned on, V_C is equal to V_E because the capacitance of C3 is much larger than the parasitic capacitance of T5. Thus, T5 is turned on, and V_B is charged to VSS. Since node A is floating, V_A is boosted by the capacitive coupling of C1 to the voltage, as shown in the following equation.

$$V_A = (V_{REF} + V_{TH_T2}) + (V_{SS} - V_{REF2}) \quad (3)$$

Therefore, the driving TFT (T1) is turned on, inducing a current to flow through the mini-LED. The emission current (I_{LED}) can be derived as follows.

$$\begin{aligned} I_{LED} &= \frac{1}{2}k(V_{GS} - V_{TH})^2 \\ &= \frac{1}{2}k(V_{REF} + V_{TH_T2} + V_{SS} - V_{REF2} \\ &\quad - V_{SS} - V_{TH_T1})^2 \\ &= \frac{1}{2}k(V_{REF} - V_{REF2})^2 \end{aligned} \quad (4)$$

where k is $\mu \cdot C_{OX} \cdot W/L$ of T1. According to Eq. (4), the V_{TH} of T1 and VSS are eliminated so the proposed circuit can generate a uniform driving current without being affected by the V_{TH} variation and the VSS I-R rise.

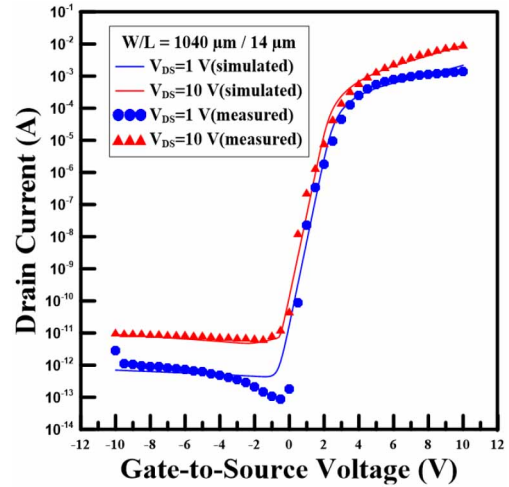

FIGURE 2. Measured and simulated transfer curves of LTPS TFT with an aspect ratio of $1040 \mu\text{m}/(7 + 7) \mu\text{m}$.

D. TURN-OFF PERIOD

S1 and S2 are maintained at low voltage level. EM goes high to turn on T6 and T7, so V_B and V_C are reset to V_{REF2} . V_A is boosted to $V_{REF} + V_{TH_T2}$ by C1, so the V_{GS} of T1 is smaller than V_{TH_T1} , and no current flows through the mini-LED. Thus, the mini-LED backlight is turned off.

By the aforementioned operation, the proposed circuit can produce a uniform driving current for the mini-LED by compensating for the V_{TH} variation and the VSS I-R rise. To achieve low power consumption, the proposed circuit has only one TFT on the driving current path and it is driven by the PWM method; hence the mini-LED can be operated at best luminance-efficacy point and the total voltage range across the circuit is narrowed. Therefore, the proposed circuit can be applied to a mini-LED back light unit for LCD applications.

III. RESULT AND DISCUSSION

Fig. 2 plots the measured and fitted transfer curves of a fabricated LTPS TFT, in which the channel width and length are $1040 \mu\text{m}$ and $14 \mu\text{m}$ ($7 \mu\text{m} + 7 \mu\text{m}$). The drain-to-source voltages (V_{DS}) are set to 1 V and 10 V. By extracting the measured data, an HSPICE simulator with RPI model (level = 62) is used to establish the simulation model. The V_{TH} of the TFT is 2.5 V. Table 1 shows the designed parameters of the proposed circuit, including the aspect ratios of the TFTs, the capacitances, the voltage swing of the signal lines, and the voltages of the power lines. T_{LED} is a diode-connected TFT that emulates the mini-LED device in the simulation. The parameters are based on the specifications of a display using an AM mini-LED backlight which has 2304 (48×48) dimming zones. The maximum luminance of the backlight is 14,000 nits.

To investigate the effectiveness of compensating for V_{TH} and VSS, Fig. 3 plots the transient waveforms of node A when the V_{TH} variation of T1 and T2 is set to ± 0.3 V and

TABLE 1. Parameters of proposed circuit.

TFT Aspect Ratio and Capacitance			
T1, T2, T _{LED} (μm/μm)	1040 / (7+7)	C1 (pF)	5
T3~T10 (μm/μm)	6 / (3+3)	C2 (pF)	1
T11, T12 (μm/μm)	4 / (4+4)	C3 (pF)	1
Voltage of Signals			
S1, S2, EM (V)	-3 ~ 15	V _{DATA} (V)	5.8 ~ 10
V _{REF} (V)	2.1	V _{DD} (V)	12.3
V _{REF2} (V)	-2	V _{SS} (V)	5.5
V _{sweep} (V)	6 ~ 11		

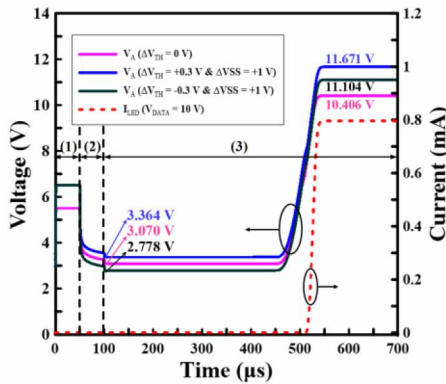
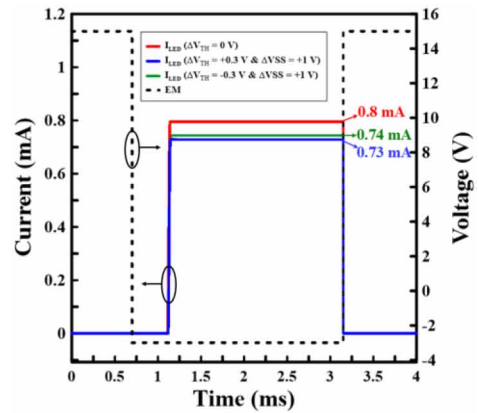

FIGURE 3. Transient waveforms of V_A and I_{LED} with V_{TH_T1} variation of ± 0.3 V and VSS rise of +1 V.

the VSS I-R rise is set to +1 V. In the end of the compensation period, the differences of the voltage at node A are 0.294 V and -0.292 V, proving that the proposed circuit can sense the V_{TH} variation of the driving TFT. During the emission stage, the differences in node A are respectively coupled to 1.265 V (0.3 V+1 V) and 0.698 V (-0.3 V +1 V) when the VSS rises by 1 V, demonstrating that the variation in VSS can be detected by the proposed circuit. Fig. 4(a) plots the simulated waveforms of the driving currents when the V_{TH} variation and the VSS I-R rise are considered. The driving currents are maintained at 0.8 mA, 0.74 mA, and 0.73 mA during the emission period. The relative current error rates are within 9%, verifying that the proposed circuit effectively compensate for the V_{TH} variation of T1 and the VSS I-R rise, keeping the mini-LED operated at the best luminance-efficacy point. To investigate further the compensating performance of the proposed circuit, Fig. 4(b) plots the relative current error rates of the state-of-the-art mini-LED driving circuit [7]. At various data voltages, the relative error rates exceed 42%. However, the current error rates of the proposed circuit are below 9%, revealing that the proposed circuit can generate uniform current for the mini-LED in spite of the V_{TH} variation of T1 and the VSS I-R rise.

In order to confirm the control-ability of the proposed circuit, Fig. 5(a) plots the driving currents with different input data voltages. Since the proposed circuit uses the PWM driving method, the emission time of the mini-LED can be modulated by V_{DATA} to differentiate the gray level. Herein, the total grayscale of the backlight is 64 and the total emission time of the backlight is set to 2000 μ s; thus, one



(a)

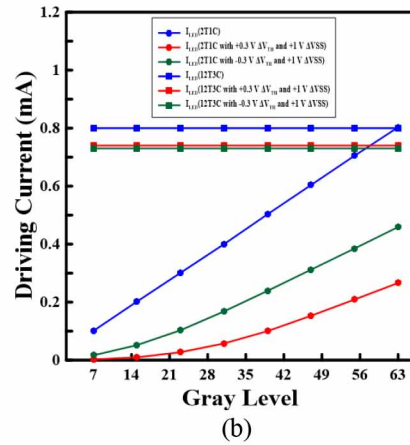

(b)

FIGURE 4. Variation in simulated mini-LED currents of (a) proposed circuit (b) 2T1C circuit with V_{TH} variation of driving TFT of ± 0.3 V and VSS I-R rise of +1 V across at all gray levels.

TABLE 2. Parameters of 6T1C circuit.

TFT Aspect Ratio and Capacitance			
T6, T _{LED} (μm/μm)	1040 / (7+7)	C1 (pF)	5
T1~T5 (μm/μm)	6 / (3+3)		
Voltage of Signals			
Scan lines (V)	-3 ~15	V _{DD} (V)	10
V _{DATA} (V)	0 ~ 6	V _{SS} (V)	1.3

grayscale is 31.25 μ s. Fig. 5(b) shows the expanded graph of Fig. 5(a) to manifest the rising times of each driving current. The rising times of the driving currents over the whole data range are all less than 11.48 μ s. The proposed circuit is capable of differentiating the gray level precisely since the emission time representing one grayscale is 31.25 μ s. To evaluate the effectiveness of the compensation for the V_{TH} variation of T12, which affects the emission time of the mini-LED, Fig. 6 plots the transient waveforms of V_D and V_E with V_{TH} variations of the control TFT, T12, ± 0.3 V. With the source-follower structure of T12, V_E detects values of 0.293 V and -0.297 V, which are close to the extremes of the variation of ± 0.3 V. Hence, T12 with different values of V_{TH} can be turned on at the same time, verifying that the emission time of the proposed circuit is independent of the

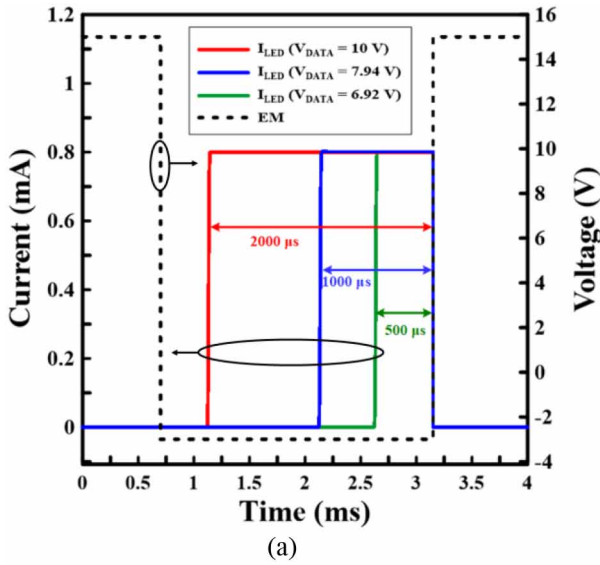

FIGURE 5. (a) Emission time and (b) rising time of driving currents of mini-LED with different input data voltages, corresponding to three gray levels.

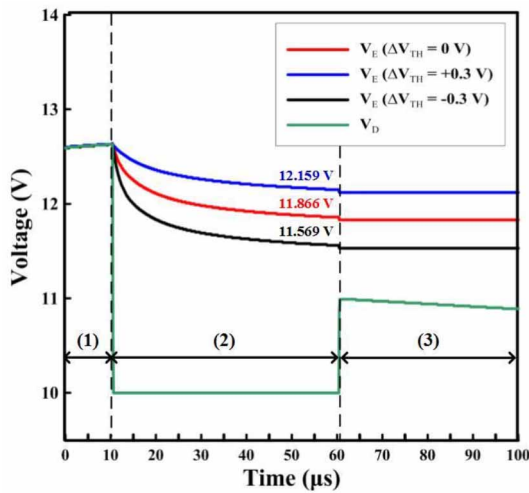

FIGURE 6. Transient voltage waveforms of V_D and V_E with V_{TH_T12} variation of $\pm 0.3\text{ V}$.

variation of T12. Fig. 7 plots the related time shift versus gray level. The time shifts are all less than 4.5 μs , verifying that the functionality of the proposed circuit that exploits the

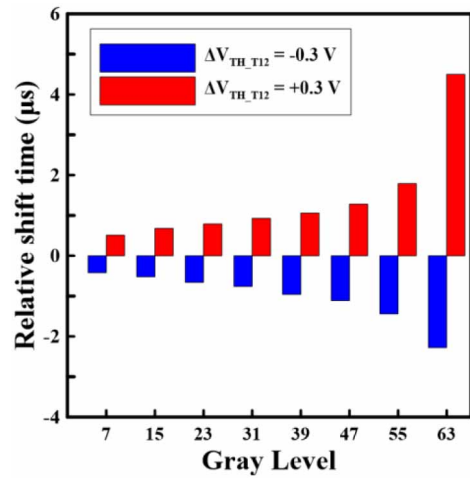

FIGURE 7. Related time shifts of emission time versus gray levels with V_{TH_T12} variation of $\pm 0.3\text{ V}$.

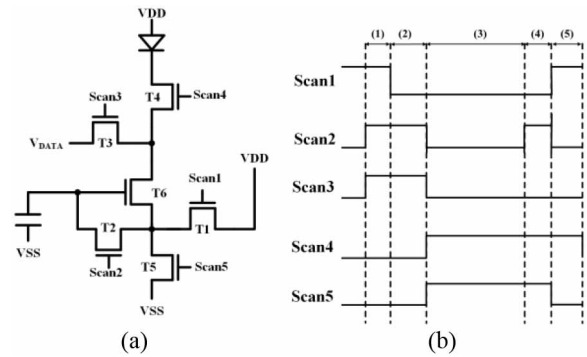

FIGURE 8. (a) Schematic and (b) timing diagram of 6T1C circuits [18].

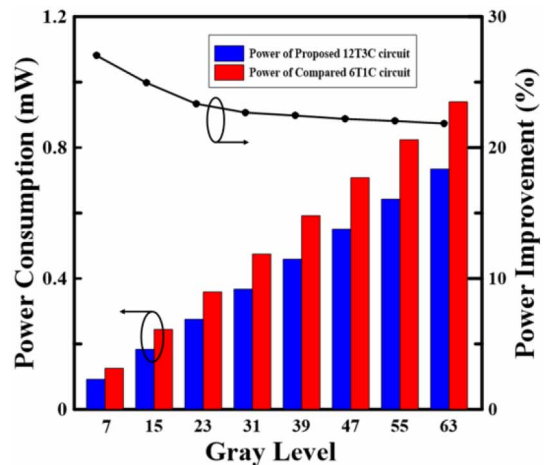

FIGURE 9. Power consumption of proposed and 6T1C circuits and relative improvement thereof versus gray levels.

PWM driving method is immune to the V_{TH} variation of the LTPS TFT. To evaluate the power saving of the proposed circuit, the power consumptions of the proposed circuit and the compensating driving circuit that are used in AM μ LED

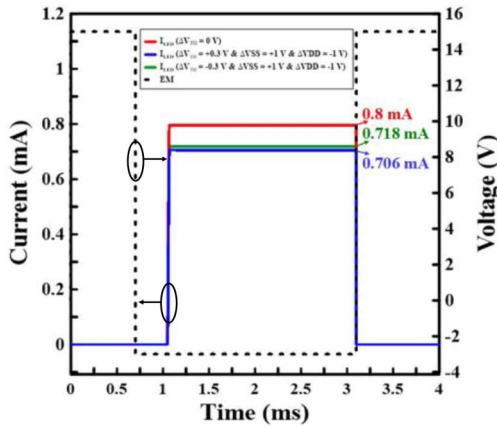

FIGURE 10. Simulated waveforms of driving current of proposed circuit with V_{TH} variation, VSS I-R rise and VDD I-R drop.

displays are compared [18]. Fig. 8 shows schematic and timing diagram of the 6T1C circuit, whose designed parameters are listed in Table 2. Herein, since the 6T1C circuit has two switching TFTs on the driving current path, the total voltage across the circuit is 1.9 V larger than that across the proposed circuit. Fig. 9 reveals that the power consumption of the proposed circuit is at least 21.84% better than that of the 6T1C circuit over the whole data voltage range. At a low gray level, the power consumption can be reduced by 27.02%, because the mini-LED that is driven by the proposed circuit is operated at the best luminance-efficacy point. Therefore, the proposed PWM driving circuit can be applied in mini-LED backlight units to improve the image quality of LCD products with a power consumption that is less than that of the compared PAM circuit [18].

IV. CONCLUSION

This work proposes a mini-LED backlight circuit that compensates for the V_{TH} variation in its driving TFTs and the VSS I-R rise to generate a uniform driving current. To reduce the power consumption of the backlight, the proposed circuit uses PWM driving method and the switching TFT on the driving current path is eliminated. Simulation results indicate that the current error rates over the whole data range are all less than 9% when the V_{TH} variation of the driving TFT is ± 0.3 V and the VSS I-R rise is +1 V. The shift in emission time at every gray level is less than 4.5 μ s, verifying the precise control of the circuit. The power consumption of the proposed circuit is at least 21.84% better than that of the normal PAM driving circuit. Therefore, the proposed circuit is suitable for use with the mini-LED backlight unit in an LCD.

**APPENDIX A
VDD I-R DROP**

Since the n-type driving TFT is operated in the saturation region in the emission period, the driving current depends on only the gate node and the source node. Therefore, the

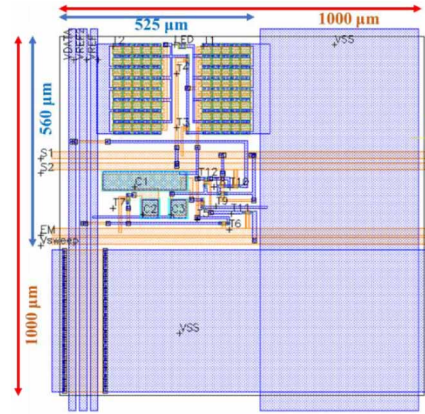

FIGURE 11. Layout image of backlight unit of proposed driving circuit.

proposed circuit is ideally immune to the VDD I-R drop. In Fig. 4(a), the simulated waveforms of the driving currents when the V_{TH} variation and the VSS I-R rise are considered are maintained at 0.8 mA, 0.74 mA, and 0.73 mA during the emission period, and the relative current error rates are within 9%. To investigate the effect of the VDD I-R drop, Fig. 10 shows the simulated waveforms of the driving currents when the VDD I-R drop is considered. The driving currents are maintained at 0.8 mA, 0.718 mA, and 0.706 mA throughout the emission period, and the relative current error rates are within 12%. Although the variation of the VDD power line is not compensated for, the error rates that are caused by the VDD I-R drop are trivial compared to those caused by the VSS I-R rise.

**APPENDIX B
CIRCUIT LAYOUT**

The specifications of the proposed circuit are based on a 2.89 inches LCD panel with 48×48 dimming zones, so the area of each mini-LED backlight unit is designed as $1000 \mu\text{m} \times 1000 \mu\text{m}$.

$$PITCH = \frac{2.89 \text{ inches}}{1.414 \times 48} \times 25.4 \text{ mm} \approx 1.081 \text{ mm}$$

Fig. 11 presents a layout image of the proposed backlight circuit. The layout area of the proposed circuit is $525 \mu\text{m} \times 560 \mu\text{m}$. The rest area of the backlight unit is covered by the VSS to reduce the intrinsic resistance and ameliorate the VSS I-R rise. Hence, the proposed circuit can be used in an AM mini-LED backlight module.

REFERENCES

- [1] H.-A. Ahn, S. Hong, and O.-k. Kwon, "An active matrix micro-pixelated LED display driver for high luminance uniformity using resistance mismatch compensation method," in *IEEE Trans. Circuits Syst. II, Exp. Briefs*, vol. 65, no. 6, pp. 724–728, Jun. 2018.
- [2] Y. E. Wu, M. H. Lee, Y. C. Lin, C. Kuo, Y. H. Lin, and W. M. Huang, "41-1: Active matrix mini-LED backlights for 1000PPI VR LCD," in *SID Symp. Dig. Tech. Papers*, May 2019, pp. 562–565.
- [3] G. Boyd, "Handbook of visual display technology," in *LCD Backlights*, J. Chen, W. Cranton, and M. Fihn, eds. Berlin, Germany: Springer, 2012.

- [4] M. Kimura *et al.*, "Low-temperature polysilicon thin-film transistor driving with integrated driver for high-resolution light emitting polymer display," *IEEE Trans. Electron Devices*, vol. 46, no. 12, pp. 2282–2288, Dec. 1999.
- [5] C. Fan, Y. Chen, C.-C. Yang, Y.-K. Tsai, and B.-R. Huang, "Novel LTPS-TFT pixel circuit with OLED luminance compensation for 3D AMOLED displays," *J. Display Technol.*, vol. 12, no. 5, pp. 425–428, May 2016.
- [6] C.-L. Lin, P.-S. Chen, M.-Y. Deng, C.-E. Wu, W.-C. Chiu, and Y.-S. Lin, "UHD AMOLED driving scheme of compensation pixel and gate driver circuits achieving high-speed operation," *IEEE J. Electron Devices Soc.*, vol. 6, pp. 26–33, Oct. 2017.
- [7] B. Liu *et al.*, "An active matrix mini-LEDs backlight based on a-Si," in *SID Symp. Dig. Tech. Papers*, vol. 51, pp. 62–64, Jul. 2020.
- [8] X. Guo and S. R. P. Silva, "Investigation on the current nonuniformity in current-mode TFT active-matrix display pixel circuitry," *IEEE Trans. Electron Devices*, vol. 52, no. 11, pp. 2379–2385, Nov. 2005.
- [9] A. Nathan, G. R. Chaji, and S. J. Ashtiani, "Driving schemes for a-Si and LTPS AMOLED displays," *J. Display Technol.*, vol. 1, no. 2, pp. 267–277, Dec. 2005.
- [10] N.-H. Keum, C.-C. Chai, S.-K. Hong, and O.-K. Kwon, "A compensation method for variations in subthreshold slope and threshold voltage of thin-film transistors for AMOLED displays," *IEEE J. Electron Devices Soc.*, vol. 7, pp. 462–469, Mar. 2019.
- [11] Y.-C. Lin and H.-P. D. Shieh, "Improvement of brightness uniformity by AC driving scheme for AMOLED display," *IEEE Electron Device Lett.*, vol. 25, no. 11, pp. 728–730, Nov. 2004.
- [12] H.-J. In *et al.*, "An advanced external compensation system for active matrix organic light-emitting diode displays with poly-Si thin-film transistor backplane," *IEEE Trans. Electron Devices*, vol. 57, no. 11, pp. 3012–3019, Nov. 2010.
- [13] C.-L. Lin, C.-C. Hung, W.-Y. Chang, M.-H. Cheng, P.-Y. Kuo, and Y.-C. Chen, "Voltage driving scheme using three TFTs and one capacitor for active-matrix organic light-emitting diode pixel circuits," *J. Display Technol.*, vol. 8, no. 10, pp. 602–608, Oct. 2012.
- [14] C.-L. Lin, C.-C. Hung, P.-S. Chen, P.-C. Lai and M.-H. Cheng, "New voltage-programmed AMOLED pixel circuit to compensate for nonuniform electrical characteristics of LTPS TFTs and voltage drop in power line," *IEEE Trans. Electron Devices*, vol. 61, no. 7, pp. 2454–2458, Jul. 2014.
- [15] J. Lee, H. Jeon, D.-S. Moon, and B. S. Bae, "Threshold voltage and IR drop compensation of an AMOLED pixel circuit without a V_{DD} line," *IEEE Electron Device Lett.*, vol. 35, no. 1, pp. 72–74, Jan. 2014.
- [16] C.-L. Lin, Y.-T. Liu, C.-E. Lee, P.-S. Chen, T.-C. Chu, and C.-C. Hung, "A-InGaZnO active-matrix organic LED pixel periodically detecting thin-film transistor threshold voltage once for multiple frames," in *IEEE Electron Device Lett.*, vol. 36, no. 11, pp. 1166–1168, Nov. 2015.
- [17] C.-L. Lin *et al.*, "New a-IGZO pixel circuit composed of three transistors and one capacitor for use in high-speed-scan AMOLED displays," *J. Display Technol.*, vol. 11, no. 12, pp. 1031–1034, Dec. 2015.
- [18] W. Shin *et al.*, "A driving method of pixel circuit using a-IGZO TFT for suppression of threshold voltage shift in AMOLED displays," *IEEE Electron Device Lett.*, vol. 38, no. 6, pp. 760–762, Jun. 2017.
- [19] M. Kimura, D. Suzuki, M. Koike, S. Sawamura, and M. Kato, "Pulsewidth modulation with current uniformization for AM-OLEDs," *IEEE Trans. Electron Devices*, vol. 57, no. 10, pp. 2624–2630, Oct. 2010.
- [20] J.-H. Kim *et al.*, "15–1: PWM pixel circuit with LTPS TFTs for micro-LED displays," in *SID Symp. Dig. Tech. Papers*, vol. 50, May 2019, pp. 192–195.



CHIH-LUNG LIN (Member, IEEE) received the M.S. and Ph.D. degrees in electrical engineering from National Taiwan University, Taipei, Taiwan, in 1993 and 1999, respectively. He is currently a Professor with the Department of Electrical Engineering, National Cheng Kung University, Tainan, Taiwan. His current research interests include pixel circuits design for AMOLEDs, gate driver circuit design for AMLCDs, and flexible display circuits.



SUNG-CHUN CHEN received the B.S. degree in electrical engineering from National Cheng Kung University, Tainan, Taiwan, in 2019, where he is currently pursuing the Ph.D. degree in electrical engineering. His research focuses on the system circuit design for mini-LED and AMOLED displays.



MING-YANG DENG received the B.S. degree in electronic engineering from the National Chin-Yi University of Technology, Taichung, Taiwan, in 2014, and the M.S. degree in electrical engineering from National Cheng Kung University, Tainan, Taiwan, in 2016, where he is currently pursuing the Ph.D. degree in electrical engineering. His current research interests include thin-film transistor circuit design for flat-panel displays and mini LED.



YUAN-HAO HO received the B.S. degree in biomedical engineering from National Cheng Kung University, Tainan, Taiwan, in 2018, where he is currently pursuing the Ph.D. degree in electrical engineering. His current research focuses on hardware design and system integration of pixel detection system for AMOLED.



CHIEH-AN LIN received the B.S. degree in electronic engineering from the National Kaohsiung University of Science and Technology, Kaohsiung, Taiwan, in 2018. He is currently pursuing the M.S. degree in electrical engineering with National Cheng Kung University, Tainan, Taiwan. His research interest includes the system circuit design for AMOLED and AMLCD displays.



CHIA-LING TSAI received the B.S. degree in electrical engineering from National Cheng Kung University, Tainan, Taiwan, in 2019, where she is currently pursuing the M.S. degree in electrical engineering. Her research focuses on the pixel circuit design for AMOLED displays.



WEI-SHENG LIAO received the B.S. and the M.S. degree in electrical engineering from National Cheng Kung University, Tainan, Taiwan, in 2018 and 2020, respectively. His research focuses on the system circuit design for mini LED and AMOLED displays.



CHIH-I LIU received the B.S. degree in electrical engineering from Feng Chia University, Tainan, Taiwan, in 2020. She is currently pursuing the M.S. degree in electrical engineering with National Cheng Kung University, Tainan. Her research focuses on the system circuit design for AMOLED displays.



JIA-TIAN PENG received the M.S. degree in chemical engineering from National Tsing Hua University, Hsinchu, Taiwan, in 1996. He is currently a Senior Manager with the AU Optronics Corporation, Hsinchu, Taiwan.



CHIA-EN WU received the B.S. and Ph.D. degrees in electrical engineering from National Cheng Kung University, Tainan, Taiwan, in 2011 and 2018, respectively. He is currently a Senior Engineering with the AU Optronics Corporation, Hsinchu, Taiwan.